



# **Vehicle Standard (Australian Design Rule 46/00 - Headlamps) 2006**

Made under section 12 of the *Road Vehicle Standards Act 2018*

Compilation: 2 (up to and including Vehicle Standard (Australian Design Rule)  
Lighting Standards Amendment Instrument 2022 (No.1))

Compilation Date: 20 January 2023

Compiled by: Vehicle Safety Policy and Partnerships, Department of Infrastructure,  
Transport, Regional Development, Communications and the Arts

**CONTENTS**

## VOLUME 1

0.	LEGISLATIVE PROVISIONS .....	3
1.	SCOPE .....	3
2.	APPLICABILITY AND IMPLEMENTATION .....	3
3.	DEFINITIONS .....	3
4.	REQUIREMENTS .....	3
5.	EXEMPTIONS AND ALTERNATIVE PROCEDURES .....	3
6.	SUPPLEMENTARY GENERAL REQUIREMENTS .....	6
7.	ALTERNATIVE STANDARDS .....	6
8.	NOTES .....	8
	APPENDIX A .....	9
	APPENDIX B .....	61
	APPENDIX C .....	115
	APPENDIX D .....	167

## VOLUME 2

	APPENDIX E .....	216
	APPENDIX F .....	263
	APPENDIX G .....	324
	COMPILATION NOTES .....	384

## **0. LEGISLATIVE PROVISIONS**

### **0.1. NAME OF STANDARD**

- 0.1.1. This Standard is the Vehicle Standard (Australian Design Rule 46/00 - Headlamps) 2006
- 0.1.2. This Standard may also be cited as Australian Design Rule 46/00 - Headlamps.

## **1. SCOPE**

This Australian Design Rule (ADR) prescribes the photometric requirements for headlamps which will provide adequate illumination for the driver of the vehicle without producing undue glare for other road users.

## **2. APPLICABILITY AND IMPLEMENTATION**

- 2.1. The circumstances under which headlamps are mandatory, optional, or prohibited are set out in either ADRs 13/..., 19/... or 67/....

## **3. DEFINITIONS**

- 3.1. Refer to paragraph 1 of Appendix A, C, D, F and G and paragraphs 2 of B and E.

## **4. REQUIREMENTS**

- 4.1. Headlamps fitted to vehicles in accordance with ADRs 13/..., 19/... or 67/...and required to comply with ADR 46/00 must comply with:
  - a) The relevant technical requirements of any of Appendix A, B, C, D, E, F or G as varied by part 5. Exemptions and Alternative Procedures and part 6. Supplementary General Requirements; or
  - b) One of the alternative standards listed in part 7. Alternative Standards.

## **5. EXEMPTIONS AND ALTERNATIVE PROCEDURES**

- 5.1. The following provisions of Appendices A, B, C, D, E, F and G do not apply to this rule

### Appendix A

Scope (including footnote 1)

Section 2 Application for approval

Section 3 Markings

Section 4 Approval

Section 7 Gauging of discomfort

Section 9 Conformity of production – partial (for particular deletions to the section refer to paragraph 5.1.1

Section 10 Penalties for non-conformity of production

Section 11 Modification and extension of approval of a type of headlamp

Section 12 Production definitely discontinued

Section 13 Names and addresses of technical services responsible for conducting approval tests and of administrative departments

	Annexes
	Annex 1      Communication concerning the approval or extension or refusal or withdrawal of approval or production definitely discontinued of a type of headlamp pursuant to Regulation No. 1
	Annex 2      Special headlamps for agricultural or forest tractors and other slow moving vehicles
	Annex 5      Examples of arrangements of approval marks
5.1.1.	Paragraphs 2.3 and 3.3 in Annex 8
5.2.	Appendix B
	Scope (including footnote 1)
	Section 3      Application for approval
	Section 4      Markings
	Section 5      Approval
	Section 11     Gauging of discomfort
	Section 12     Conformity of production – partial ( for particular deletions to the section refer to paragraph 5.2.1)
	Section 13     Penalties for non conformity of production
	Section 14     Modification of the type of sealed beam headlamp unit (SB) unit and extension of approval
	Section 15     Production definitely discontinued
	Section 16     Transitional provisions
	Section 17     Names and addresses of technical services responsible for conducting approval tests and of administrative departments
	Annexes
	Annex 1      SB units for agricultural or forest tractors and other slow moving vehicles
	Annex 2      Communications concerning the approval or extension or refusal or withdrawal of approval or production definitely discontinued of a sealed beam headlamp unit (SB) pursuant to Regulation No. 5
	Annex 4      Examples of arrangements of approval marks
5.2.1.	Paragraphs 2.3 and 3.3 in Annex 7.
5.3.	Appendix C
	Scope (including footnote 1)
	Section 2      Application for approval of headlamp
	Section 3      Markings
	Section 4      Approval
	Section 8      Gauging of discomfort
	Section 10     Observation concerning colour
	Section 11     Modification and extension of approval of a type of headlamp
	Section 12     Conformity of production – partial (for particular deletions to the section refer to paragraph 5.3.1)
	Section 13     Penalties for non conformity of production
	Section 14     Production definitely discontinued
	Section 15     Names and addresses of technical services responsible for conducting approval tests and of administrative departments

	Annexes	
	Annex 1	Communication concerning the approval (or extension or refusal or withdrawal of approval or production definitely discontinued) of a type of headlamp pursuant to Regulation No. 8
	Annex 3	Examples of arrangements of approval marks
5.3.1.	Paragraphs 2.3 and 3.3 in Annex 7	
5.4.	Appendix D	
	Scope (including footnote 1)	
	Section 2	Application for approval of headlamp
	Section 3	Markings
	Section 4	Approval
	Section 8	Gauging of discomfort
	Section 10	Observation concerning colour
	Section 11	Modification and extension of approval of a type of headlamp
	Section 12	Conformity of production – partial (for particular deletions to the section refer to paragraph 5.4.1)
	Section 13	Penalties for non conformity of production
	Section 14	Production definitely discontinued
	Section 15	Names and addresses of technical services responsible for conducting approval tests and of administrative departments
	Annexes	
	Annex 1	Communication concerning the approval or extension or refusal or withdrawal of approval or (production definitely discontinued) of a type of headlamp to Regulation No. 20
	Annex 2	Arrangement of arrangements of approval mark
5.4.1.	Paragraphs 2.3 and 3.3 in Annex 7.	
5.5.	Appendix E	
	Scope (including footnote1)	
	Section 3	Application for approval
	Section 4	Markings
	Section 5	Approval
	Section 9	Colour
	Section 10	Gauging of discomfort
	Section 11	Conformity of production – partial (for particular deletions to the section refer to paragraph 5.5.1)
	Section 12	Penalties for non conformity of production
	Section 13	Modification and extension of approval of a type of halogen sealed beam headlamp unit (HSB) unit
	Section 14	Production definitely discontinued
	Section 15	Transitional provisions
	Section 16	Names and addresses of technical services responsible for conducting approval tests and of administrative departments
	Annexes	
	Annex 1	Communications concerning the approval or extension or refusal or withdrawal of approval or production definitely

- discontinued of a sealed beam headlamp unit (SB) pursuant to Regulation No. 31
- Annex 2 Examples of arrangements of approval marks
- 5.5.1. Paragraphs 2.3 and 3.3 in Annex 8.
- 5.6. Appendix F
- Section 2 Application for approval of a headlamp
- Section 3 Marking
- Section 4 Approval
- Section 9 Modification of the headlamp type and extension of approval
- Section 10 Conformity of Production
- Section 11 Penalties for non-conformity of production
- Section 12 Production definitely discontinued
- Section 13 Names and addresses of Technical Services responsible for conducting approval tests, and of Administrative Departments
- Annex 1 Communication
- Annex 2 Examples of arrangement of approval marks
- Annex 5 Minimum requirements for conformity of production control procedures
- Annex 7 Minimum requirements for sampling by an inspector
- 5.7. Appendix G
- Section 2 Application for approval of a headlamp
- Section 3 Marking
- Section 4 Approval
- Section 9 Modification of the headlamp type and extension of approval
- Section 10 Conformity of Production
- Section 11 Penalties for non-conformity of production
- Section 12 Production definitely discontinued
- Section 13 Names and addresses of Technical Services responsible for conducting approval tests, and of Administrative Departments
- Annex 1 Communication
- Annex 2 Examples of arrangement of approval marks
- Annex 5 Minimum requirements for conformity of production control procedures
- Annex 7 Minimum requirements for sampling by an inspector

## 6. SUPPLEMENTARY GENERAL REQUIREMENTS

The following general requirements are supplementary to the requirements of Appendix A:

- 6.1. The requirements and procedures set out in Annexes 6 and 7 in Appendix A, Annexes 3 and 7 in Appendix B, Annexes 2 and 7 in Appendix C, Annexes 5 and 7 in Appendix D and Annexes 5 and 8 in Appendix E are acceptable for the purposes of demonstrating compliance with the requirements of this rule.

## 7. ALTERNATIVE STANDARDS

- 7.1. The technical requirements of any of the editions of United Nations Regulation No 1 – UNIFORM PROVISIONS CONCERNING THE APPROVAL OF MOTOR VEHICLE HEADLAMPS EMITTING AN ASYMMETRICAL

PASSING BEAM AND/OR A DRIVING BEAM AND EQUIPPED WITH FILAMENT LAMPS OF CATEGORY R2 AND /OR HS1 from the version incorporating the 01 series of amendments.

- 7.2. The technical requirements of any of the editions of United Nations Regulation No 5 – UNIFORM PROVISIONS CONCERNING THE APPROVAL OF POWER-DRIVEN VEHICLE’S “SEALED BEAM” HEADLAMPS (SB) EMITTING A EUROPEAN ASYMMETRICAL PASSING BEAM OR A DRIVING BEAM OR BOTH, from the version incorporating the 01 series of amendments up to and including the version incorporating the 02 series of amendments.
- 7.3. The technical requirements of any of the editions of United Nations Regulation No 8 – UNIFORM PROVISIONS CONCERNING THE APPROVAL OF MOTOR VEHICLE HEADLAMPS EMITTING AN ASYMMETRICAL PASSING BEAM OR A DRIVING BEAM OR BOTH AND EQUIPPED WITH HALOGEN FILAMENT LAMPS (H<sub>1</sub>, H<sub>2</sub>, H<sub>3</sub>, HB<sub>3</sub>, HB<sub>4</sub>, H<sub>7</sub>, H<sub>8</sub>, H1R1, H1R2 and/or H<sub>11</sub>), from the version incorporating the 03 series of amendments.
- 7.4. The technical requirements of any of the editions of United Regulation No 20 – UNIFORM PROVISIONS CONCERNING THE APPROVAL OF MOTOR VEHICLE HEADLAMPS EMITTING AN ASYMMETRICAL PASSING BEAM OR A DRIVING BEAM OR BOTH AND EQUIPPED WITH HALOGEN FILAMENT LAMPS (H4 LAMPS), from the version incorporating the 01 series of amendments.
- 7.5. The technical requirements of any of the editions of United Nations Regulation No 31 – UNIFORM PROVISIONS CONCERNING THE APPROVAL OF POWER-DRIVEN VEHICLE’S HALOGEN SEALED-BEAM HEADLAMPS (HSB) EMITTING AN EUROPEAN ASYMMETRICAL PASSING BEAM OR A DRIVING BEAM OR BOTH, from the version incorporating the 01 series of amendments.
- 7.6. The technical requirements of any of the editions of United Regulation 112 – UNIFORM PROVISIONS CONCERNING THE APPROVAL OF MOTOR VEHICLE HEADLAMPS EMITTING AN ASYMMETRICAL PASSING BEAM OR A DRIVING BEAM OR BOTH AND EQUIPPED WITH FILAMENT LAMPS AND/OR LIGHT-EMITTING DIODE (LED) MODULES.
- 7.7. The technical requirements of any of the editions of United Nations Regulation 113 – UNIFORM PROVISIONS CONCERNING THE APPROVAL OF MOTOR VEHICLE HEADLAMPS EMITTING A SYMMETRICAL PASSING BEAM OR A DRIVING BEAM OR BOTH AND EQUIPPED WITH FILAMENT, GAS-DISCHARGE LIGHT SOURCES OR LED MODULES.
- 7.8. The technical requirements of SAE Standards J579c, December 1978, “Sealed Beam Headlamp Units for Motor Vehicles”.
- 7.9. The technical requirements of JIS D5500-1995, “Lighting and Signalling Equipment for Automobiles” for asymmetric Grade A, B1 and B2 headlamps.

**8. NOTES**

- 8.1. In place of Regulation No 48 where referenced in Appendix A, read ADR 13/00.
- 8.2. In place of Regulation No 37 where referenced in Appendix A, read ADR 51/00.

## **APPENDIX A**

UN REGULATION No. 1/01

UNIFORM PROVISIONS CONCERNING THE APPROVAL OF MOTOR VEHICLE  
HEADLAMPS EMITTING AN ASYMMETRICAL PASSING BEAM AND/OR A  
DRIVING BEAM AND EQUIPPED WITH FILAMENT LAMPS OF CATEGORY R2 AND  
/OR HS1

## **Regulation No. 1**

### **UNIFORM PROVISIONS CONCERNING THE APPROVAL OF MOTOR VEHICLE HEADLAMPS EMITTING AN ASYMMETRICAL PASSING BEAM AND/OR A DRIVING BEAM AND EQUIPPED WITH FILAMENT LAMPS OF CATEGORIES R2 AND/OR HS1**

#### **Contents**

#### **REGULATION**

##### SCOPE

1. DEFINITIONS
2. APPLICATION FOR APPROVAL
3. MARKINGS
4. APPROVAL
5. GENERAL SPECIFICATIONS
6. ILLUMINATION
7. GAUGING OF DISCOMFORT
8. STANDARD HEADLAMP
9. CONFORMITY OF PRODUCTION
10. PENALTIES FOR NON-CONFORMITY OF PRODUCTION
11. MODIFICATION AND EXTENSION OF APPROVAL OF TYPE OF HEADLAMP
12. PRODUCTION DEFINITELY DISCONTINUED
13. NAMES AND ADDRESSES OF TECHNICAL SERVICES RESPONSIBLE FOR CONDUCTING APPROVAL TESTS, AND OF ADMINISTRATIVE DEPARTMENTS

#### **ANNEXES**

- Annex 1 -Communication concerning the approval or extension or refusal or withdrawal of approval or, production definitely discontinued of a type of headlamp pursuant to Regulation No.1
- Annex 2 -Special headlamps for agricultural or forest tractors and other slow-moving vehicles
- Annex 3 -Minimum requirements for conformity of production control procedures
- Annex 4 -Tests for stability of photometric performance of headlamps in operation
- Annex 5 -Examples of arrangements of approval marks
- Annex 6 -Measuring screens
- Annex 7 -Requirements for lamps incorporating lenses of plastic material -testing of lens or material samples and of complete lamps

- Appendix 1 -Chronological order of approval tests
- Appendix 2 -Method of measurement of the diffusion and transmission of light
- Appendix 3 -Spray testing method
- Appendix 4 -Adhesive tape adherence test
- Annex 8 -Minimum requirements for sampling by an inspector

## **Regulation No. 2**

### **UNIFORM PROVISIONS CONCERNING THE APPROVAL OF INCANDESCENT ELECTRIC LAMPS FOR HEADLAMPS EMITTING AN ASYMMETRICAL PASSING BEAM OR A DRIVING BEAM OR BOTH**

#### **Contents**

#### **REGULATION**

1. Transitional provisions

## **Regulation No. 1**

### **UNIFORM PROVISIONS CONCERNING THE APPROVAL OF MOTOR VEHICLE HEADLAMPS EMITTING AN ASYMMETRICAL PASSING BEAM AND/OR A DRIVING BEAM**

#### **AND EQUIPPED WITH FILAMENT LAMPS OF CATEGORIES R2 AND/OR HS1**

#### **SCOPE** <sup>\*/</sup>

This Regulation applies to motor vehicle headlamps which may incorporate lenses of glass or plastic material.

#### **1. DEFINITIONS**

For the purpose of this Regulation

- 1.1. "Lens" means the outermost component of the headlamp (unit) which transmits light through the illuminating surface;
- 1.2. "Coating" means any product or products applied in one or more layers to the outer face of a lens;
- 1.3. Headlamps of different "types" are headlamps which differ in such essential respects as:
  - 1.3.1. The trade name or mark;
  - 1.3.2. The characteristics of the optical system;
  - 1.3.3. The inclusion of additional components capable of altering the optical effects by reflection, refraction or absorption; and/or deformation during operation;
  - 1.3.4. Suitability for right-hand or left-hand traffic or for both traffic systems;
  - 1.3.5. Ability to provide a passing-beam or a driving-beam or both;
  - 1.3.6. The materials constituting the lenses and coating, if any.
  - 1.3.7. The holder intended to accommodate the filament lamp (or lamps) of one of the following categories: R2 and/or HS1;<sup>2/</sup>

#### **2. APPLICATIONS FOR APPROVAL** <sup>1/</sup>

- 2.1. The application for approval shall be submitted by the owner of the trade name or mark or by his duly accredited representative. It shall specify:

Whether the headlamp is intended to provide both a passing beam and a driving beam or only one of these beams;

---

<sup>\*/</sup> Nothing in this Regulation shall prevent a Party to the Agreement applying this Regulation from prohibiting the combination of a headlamp incorporating a lens of plastic material approved under this Regulation with a mechanical headlamp-cleaning device (with wipers).

<sup>2/</sup> "Type of filament lamp" should not be confused with "category of filament lamp". This Regulation concerns headlamps using filament lamps of categories R2 and/or HS1. These categories of filament lamps differ essentially in their design and, more particularly, in the cap. They are not interchangeable, but within one filament lamp category there are normally several types.

<sup>1/</sup> Application for approval of a filament lamp: see Regulation No. 37.

Whether, if the headlamp is intended to provide a passing beam, it is designed for both left-hand and right-hand traffic or for either left-hand or right-hand traffic only.

If the headlamp is equipped with an adjustable reflector, the mounting position(s) of the headlamp in relation to the ground and the longitudinal median plane of the vehicle.

2.2. The application shall be accompanied, in respect of each type of headlamp, by:

2.2.1. Drawings in triplicate, in sufficient detail to permit identification of the type and representing a frontal view of the headlamp, with details of lens ribbing, if any, and the cross-section; the drawings shall indicate the space reserved for the approval mark;

If the headlamp is equipped with an adjustable reflector, an indication of the mounting position(s) of the headlamp in relation to the ground and the longitudinal median plane of the vehicle, if the headlamp is for use in that (those) position(s) only.

2.2.2. A brief technical specification;

2.2.3. Two samples of the type of headlamp;

2.2.4. For the test of plastic material of which the lenses are made;

2.2.4.1. Thirteen lenses.

2.2.4.1.1. Six of these lenses may be replaced by six samples of material at least 60 x 80 mm in size, having a flat or convex outer surface and a substantially flat area (radius of curvature not less than 300 mm) in the middle measuring at least 15 x 15 mm.

2.2.4.1.2. Every such lens or sample of material shall be produced by the method to be used in mass production.

2.2.4.2. A reflector to which the lenses can be fitted in accordance with the manufacturer's instructions.

2.3. The characteristics of the materials making up the lenses and coatings, if any, accompanied by the test report on these materials and coatings if they have already been tested.

2.4. The competent authority shall verify the existence of satisfactory arrangements for ensuring effective control of the conformity of production before type approval is granted.

### **3. MARKINGS**<sup>3/</sup>

3.1. Headlamps submitted for approval shall bear the trade name or mark of the applicant.

3.2. They shall comprise, on the lens and on the main body<sup>4/</sup>, spaces of sufficient size for the approval mark and the additional symbols referred to in Paragraph 4; these spaces shall be indicated on the drawings referred to in Paragraph 2.2.1 above.

---

<sup>3/</sup> In the case of headlamps designed to meet the requirements of traffic moving on one side of the road only (either right or left), it is further recommended that the area which can be occulted to prevent discomfort to users in a country where traffic moves on the opposite side of the road should be outlined indelibly on the front lens. This marking is not necessary, however, where the area is clearly apparent from the design.

- 3.3. In the case of headlamps designed to satisfy the requirements both of countries with right-hand traffic and of countries with left-hand traffic, the two settings of the optical unit on the vehicle or of the filament lamp on the reflector shall be marked by the capital letters R and D, and L and G, respectively.
- If the lens cannot be detached from the main body of the headlamp, a space on the lens shall be sufficient.
4. APPROVAL
- 4.1. General
- 4.1.1. If all the samples of a type of headlamp submitted pursuant to Paragraph 2 above satisfy the provisions of this Regulation, approval shall be granted.
- 4.1.2. Where grouped, combined or reciprocally incorporated lamps satisfy the requirements of more than one Regulation, a single international approval mark may be affixed provided that each of the grouped, combined or reciprocally incorporated lamps satisfies the provisions applicable to it.
- This requirement shall not apply to headlamps fitted with a two-filament bulb when a single beam is approved.
- 4.1.3. An approval number shall be assigned to each type approved. The same Contracting Party may not assign the same number to another type of headlamp covered by this Regulation except in the case of an extension of the approval to a device differing only in the colour of the light emitted.
- 4.1.4. Notice of approval or of extension or refusal of approval of a type of headlamp pursuant to this Regulation shall be communicated to the Parties to the 1958 Agreement applying this Regulation by means of a form conforming to the model shown in Annex 1 to this Regulation, with the indications according to Paragraph 2.2.1 and if the headlamp is equipped with an adjustable reflector and if the headlamp is to be used only in mounting positions according to the indications in Paragraph 2.2.1, the applicant shall be obliged by the approval to inform the user in a proper way about the correct mounting position(s).
- 4.1.5. In addition to the mark prescribed in Paragraph 3.1, an approval mark as described in Paragraphs 4.2 and 4.3 below shall be affixed in the spaces referred to in Paragraph 3.2 above to every headlamp conforming to a type approved under this Regulation.
- 4.2. Composition of approval mark
- The approval mark shall consist of:
- 4.2.1. An international approval mark comprising:
- 4.2.1.1. A circle surrounding the letter "E" followed by the distinguishing number of the country which has granted approval;<sup>5/</sup>

---

<sup>4/</sup> If the lens cannot be detached from the main body of the headlamp, a space on the lens shall be sufficient.

<sup>5/</sup> 1 for Germany, 2 for France, 3 for Italy, 4 for the Netherlands, 5 for Sweden, 6 for Belgium, 7 for Hungary, 8 for the Czech Republic, 9 for Spain, 10 for Yugoslavia, 11 for the United Kingdom, 12 for Austria, 13 for Luxembourg, 14 for Switzerland, 15 (vacant), 16 for Norway, 17 for Finland, 18 for Denmark, 19 for Romania, 20 for Poland, 21 for Portugal, 22 for the Russian Federation, 23 for Greece, 24 (vacant), 25 for Croatia, 26 for Slovenia, 27 for Slovakia, 28 for Belarus, 29 for Estonia, 30 (vacant), 31 for Bosnia and Herzegovina, 32-36 (vacant) and 37 for Turkey. Subsequent numbers will be assigned to other countries in the chronological order

- 4.2.1.2. The approval number prescribed in Paragraph 4.1.3 above.
- 4.2.2. The following additional symbol (or symbols):
- 4.2.2.1. On headlamps meeting left-hand traffic requirements only, a horizontal arrow, pointing to the right of an observer facing the headlamp, i.e. to the side of the road on which traffic moves;
- 4.2.2.2. On headlamps designed to meet the requirements of both traffic systems by means of an appropriate adjustment of the setting of the optical unit or the filament lamp, a horizontal arrow with a head on each end, the heads pointing respectively to the left and to the right;
- 4.2.2.3. On headlamps meeting the requirements of this Regulation in respect of the passing beam only, the letter "C";
- 4.2.2.4. On headlamps meeting the requirements of this Regulation in respect of the driving beam only, the letter "R";
- 4.2.2.5. On headlamps meeting the requirements of this Regulation in respect of both the passing beam and the driving beam, the letters "CR";
- 4.2.2.6. On headlamps incorporating a lens of plastic material, the group of letters "PL" shall be affixed near the symbols prescribed in Paragraphs 4.2.2.3 to 4.2.2.5 above.
- 4.2.2.7. In every case the relevant operating mode used during the test procedure according to Paragraph 1.1.1.1 of Annex 4 and the permitted voltage(s) according to Paragraph 1.1.1.2 of Annex 4 shall be stipulated on the approval certificate and on the communication form transmitted to the countries which are Contracting Parties to the Agreement and which apply this Regulation.
- In the corresponding cases the device shall be marked as follows:
- On headlamps meeting the requirements of this Regulation which are so designed that the filament of the passing beam shall not be lit simultaneously with that of any other lighting function with which it may be reciprocally incorporated: an oblique stroke (/) shall be placed behind the passing lamp symbol in the approval mark.
- On headlamps meeting the requirements of Annex 4 to this Regulation only when supplied with a voltage of 6 V or 12 V, a symbol consisting of the number 24 crossed out by an oblique cross (X), shall be placed near the filament lamp holder.
- 4.2.2.8. The two digits of the approval number which indicate the series of amendments in force at the time of issue of the approval and, if necessary, the required arrow may be marked close to the above additional symbols.
- 4.2.2.9. The marks and symbols referred to in Paragraphs 4.2.1 and 4.2.2 above shall be clearly legible and be indelible even when the device is fitted in the vehicle.
- 4.3. Arrangement of the approval mark
- 4.3.1. Independent lamps

---

in which they ratify or accede to the Agreement concerning the Adoption of Uniform Conditions of Approval and Reciprocal Recognition of Approval for Motor Vehicle Equipment and Parts, and the numbers thus assigned shall be communicated to the Contracting Parties to the Agreement by Secretary-General of the United Nations .

Annex 5, Figures 1 to 9, to this Regulation gives examples of arrangements of the approval marks with the above-mentioned additional symbols.

4.3.2. Grouped, combined or reciprocally incorporated lamps

4.3.2.1. Where grouped, combined or reciprocally incorporated lamps have been found to comply with the requirements of several Regulations, a single international approval mark may be affixed, consisting of a circle surrounding the letter "E" followed by the distinguishing number of the country which has granted the approval, and an approval number. This approval mark may be located anywhere on the grouped, combined or reciprocally incorporated lamps, provided that:

4.3.2.1.1. It is visible after their installation;

4.3.2.1.2. No part of the grouped, combined or reciprocally incorporated lamps that transmits light can be removed without at the same time removing the approval mark.

4.3.2.2. The identification symbol for each lamp appropriate to each Regulation under which approval has been granted, together with the corresponding series of amendments incorporating the most recent major technical amendments to the Regulation at the time of issue of the approval and, if necessary, the required arrow shall be marked:

4.3.2.2.1. Either on the appropriate light-emitting surface,

4.3.2.2.2. Or in a group, in such a way that each of the grouped, combined or reciprocally incorporated lamps may be clearly identified (see three possible examples in Annex 5).

4.3.2.3. The size of the components of a single approval mark shall not be less than the minimum size required for the smallest of the individual marks by the Regulation under which approval has been granted.

4.3.2.4. An approval number shall be assigned to each type approved. The same Contracting Party may not assign the same number to another type of grouped, combined or reciprocally incorporated lamps covered by this Regulation.

4.3.2.5. Annex 5, Figure 10, to this Regulation gives examples of arrangements of approval marks for grouped, combined or reciprocally incorporated lamps with all the above-mentioned additional symbols.

4.3.3. Lamps, the lens of which is used for different types of lamps and which may be reciprocally incorporated or grouped with other lamps

The provisions laid down in Paragraph 4.3.2 above are applicable.

4.3.3.1. In addition, where the same lens is used, the latter may bear the different approval marks relating to the different types of headlamps or units of lamps, provided that the main body of the headlamp, even if it cannot be separated from the lens, also comprises the space described in Paragraph 3.2 above and bears the approval marks of the actual functions. If different types of headlamps comprise the same main body, the latter may bear the different approval marks.

4.3.3.2. Annex 5, Figure 11, to this Regulation gives examples of approval marks relating to the above case.

**5. GENERAL SPECIFICATIONS**

- 5.1. Each sample shall conform to the specifications set forth in Paragraphs 6 and 7 below.
- 5.2. Headlamps shall be so made as to retain their prescribed photometric characteristics and to remain in good working order when in normal use, in spite of the vibrations to which they may be subjected.
- 5.3. Headlamps shall be fitted with a device enabling them to be so adjusted on the vehicle as to comply with the rules applicable to them. Such a device need not be fitted on components in which the reflector and the diffusing lens cannot be separated provided the use of such units is confined to vehicles on which the headlamps setting can be adjusted by other means. Where a headlamp providing a driving beam and a headlamp providing a passing beam, each equipped with its own filament lamp, are assembled to form a composite unit, the adjusting device shall enable each optical system individually to be duly adjusted.

However, this shall not apply to headlamps assemblies whose reflectors are indivisible. For this type of assembly, the requirements of Paragraph 6 shall apply.

- 5.4. The components by which the filament lamp is fixed to the reflector shall be so made that, even in darkness, the filament lamp can be fixed in no position but the correct one. The filament lamp-holder shall conform to the dimensional characteristics as given in the following data sheets of IEC Publication 61-2:

Filament lamp	Holder	Data sheet
R2	P45t-41	7005-95-1
HS1	PX43t	7005-34-1

- 5.5. Headlamps designed to satisfy the requirements both of countries in which traffic moves on the right and of those in which it moves on the left may be adapted for traffic on a given side of the road either by an appropriate initial adjustment when the vehicle is fitted out or by selective setting by the driver. Such initial adjustment or selective setting shall consist, for example, of fixing either the optical unit at a given angle on the vehicle or the filament lamp at a given angle in relation to the optical unit. In all cases, only two precisely differentiated setting positions, one for right-hand and one for left-hand traffic, shall be possible, and the design shall preclude inadvertent shifting of the headlamp from one position to another or its setting in an intermediate position. Where two different setting positions are provided for the filament lamp, the components attaching the filament lamp to the reflector must be so designed and manufactured that, in each of its two settings, the filament lamp will be held in position with the precision required for headlamps intended for traffic on only one side of the road.
- 5.6. Complementary tests shall be done according to the requirements of Annex 4 to ensure that in use there is no excessive change in photometric performance.
- 5.7. Conformity with the requirements of Paragraphs 5.2 to 5.5 shall be verified visually and, where necessary, by a test fitting.
- 5.8. If the lens of the headlamp is of plastic material, tests shall be done according to the requirements of Annex 7.

## 6. ILLUMINATION

6.1. Headlamps shall be so made that with suitable R2 and/or HS1 filament lamp(s) they provide adequate illumination without dazzle in the case of passing beam and good illumination in the case of the driving beam.

6.1.1. The illumination produced by the headlamp shall be checked on a vertical screen set at a distance of 25 m in front of the headlamp and at right angles to its axis (see annex 6).

6.1.2. The headlamp shall be checked by means of (a) standard (etalon) filament lamp(s) designed for a rated voltage of 12 V, any selective-yellow filters <sup>6/</sup> being replaced by geometrically identical uncoloured filters with a transmission factor of at least 80%. During the checking of the headlamp the voltage at the terminals of the filament lamp shall be regulated so as to obtain the following characteristics:

Filament lamp category	Approximate supply voltage (V) for measurement	Light flux (in lumens)	
		driving beam filament	passing beam filament
R2	12	700	450
HS1	12	700	450

6.1.3. The dimensions determining the position of the filament(s) and the shield inside the standard filament lamp are shown on the relevant data sheet of Regulation No. 37.

6.1.4. The bulb of the standard filament lamp shall be of such optical shape and quality that it does not cause any reflection or refraction adversely affecting the light distribution. Compliance with this requirement shall be checked by measuring the light distribution obtained when a standard headlamp is fitted with the standard (etalon) filament lamp.

6.2. The passing beam must produce a sufficiently sharp "cut-off" to permit satisfactory adjustment with its aid. The "cut-off" must be a horizontal straight line on the side opposite to the direction of the traffic for which the headlamp is intended; on the other side it should be horizontal or within an angle of 15 degrees above the horizontal. The headlamp shall be so adjusted that:

6.2.1. In the case of headlamps designed to meet the requirements of right-hand traffic, the "cut-off" on the left half of the screen <sup>7/</sup> is horizontal and, in the case of headlamps designed to meet the requirements of left-hand traffic, the "cut-off" on the right half of the screen is horizontal;

<sup>6/</sup> These filters shall consist of all the components, including the lens, which are intended to colour the light.

<sup>7/</sup> The adjustment screen should be sufficiently wide to allow examination of the "cut-off" over a range of at least 5 degrees from the line vv.

6.2.2. This horizontal part of the "cut-off" is situated on the screen 25 cm below the outline of the horizontal plane passing through the focus of the headlamp (See Annex 6 to this Regulation);

6.2.3. The screen is in the position indicated in Annex 6<sup>8/</sup>.

When so adjusted, the headlamp shall, if it is intended to provide a passing beam and a driving beam, comply with the requirements referred to in Paragraphs 6.3 and 6.4 below. If it is intended primarily to provide a passing beam, it need comply only with the requirements referred to in Paragraph 6.3<sup>9/</sup>.

Where a headlamp so adjusted does not meet the requirements referred to in Paragraphs 6.3 and 6.4, its adjustment may be changed, provided that the axis of the beam or the point of intersection HV specified Annex 6 to this Regulation is not laterally displaced by more than 1 degrees (= 44 cm) to the right or left<sup>10/</sup>. To facilitate adjustment by means of the "cut-off", the headlamp may be partially occulted in order to sharpen the "cut-off".

If the headlamp is designed solely to provide a driving beam, it shall be so adjusted that the area of maximum illumination is centred on the point of intersection of the lines hh and vv. Such a headlamp need meet only the requirements referred to in Paragraph 6.5.

If, in the case of a headlamp designed to satisfy the requirements of this Regulation with respect to the passing beam only, the focal axis diverges appreciably from the general direction of the beam, lateral adjustment shall be effected to the manner which best satisfies the requirements for illumination at points 75 and 50.

The limit of non-adjustment of  $1^\circ$  to the right or left is not incompatible with vertical non-adjustment. The latter is limited only by the requirements of Paragraph 6.4.

6.3. The illumination produced on the screen by the passing beam shall meet the requirements of the following Table<sup>11/</sup>:

---

<sup>8/</sup> If, in the case of a headlamp designed to satisfy the requirements of this Regulation with respect to the passing beam only, the focal axis diverges appreciably from the general direction of the beam, lateral adjustment shall be effected to the manner which best satisfies the requirements for illumination at points 75 and 50.

<sup>9/</sup> A "passing beam" headlamp of this kind may incorporate a driving beam for which no specifications are laid down.

<sup>10/</sup> The limit of non-adjustment of  $1^\circ$  to the right or left is not incompatible with vertical non-adjustment. The latter is limited only by the requirements of Paragraph 6.4.

<sup>11/</sup> See Annex 2 on the subject of special headlamps for agricultural or forest tractors and other slow-moving vehicles.

Point on measuring screen		Required
Headlamps for right-hand traffic	Headlamps for left-hand traffic	Illumination in lux
Point B 50 L	Point B 50 R	< 0.4
Point B 75 R	Point B 75 L	> 6 >
Point B 50 R	Point B 50 L	6
Point B 25 L	Point B 25 R	> 1.5
Point B 25 R	Point B 25 L	> 1.5
Any point in zone III		< 0.7
Any point in zone IV		> 2
Any point in zone I		< 20

It is understood that, where the flux of the standard filament lamp used for measurement is other than 450 lumens, the measurements as taken will be corrected proportionally to the rates of the fluxes. There shall be no lateral variations detrimental to good visibility in any of the zones, I, II, III and IV.

Headlamps designed to meet the requirements of both right-hand and left-hand traffic must, in each of the two setting positions of the optical unit or of the filament lamp, meet the requirements set forth above for the corresponding traffic system.

- 6.4. The illumination values in zones "A" and "B" <sup>\*/</sup> as shown in Figure PIC in Annex 6 shall be checked by the measurement of the photometric values of points 1 to 8 on this Figure; these values shall lie within the following limits:

$$1 + 2 + 3 > 0.3 \text{ lux, and } 4 + 5 + 6 > 0.6 \text{ lux, and } 0.7 \text{ lux} > 7 > 0.1 \text{ lux and } 0.7 \text{ lux} > 8 > 0.2 \text{ lux}$$

These new values shall not be required for headlamps which have been approved before the application date of Supplement 3 to the 01 series of amendments to this Regulation (2 December 1992) nor to the extensions of such approvals.

- 6.5. In the case of headlamps with an adjustable reflector the requirements of Paragraphs 6.2 to 6.4 are applicable for each mounting position indicated according to Paragraph 2.1. For verification the following procedure shall be used:

- 6.5.1. Each applied position is realized on the test goniometer with respect to a line joining the centre of the light source and point HV on the aiming screen. The adjustable reflector is then moved into such a position that the light pattern on the screen corresponds to the aiming prescriptions of Paragraphs 6.1, 6.2 and/or 6.4;

<sup>\*/</sup> Illumination values in any point of zones A and B, which also lies within zone III, shall not exceed 0.7 lux.

- 6.5.2. With the reflector initially fixed according to Paragraph 6.5.1, the headlamp must meet the relevant photometric requirements of Paragraphs 6.2, 6.3 and 6.4;
- 6.5.3. Additional tests are made after the reflector has been moved vertically +/- 2 degrees or at least into the maximum position, if less than 2 degrees, from its initial position by means of the headlamps adjusting device. Having re-aimed the headlamp as a whole (by means of the goniometer for example) in the corresponding opposite direction the light output in the following directions shall be controlled and lie within the required limits: passing beam: points HV and 75R (75L respectively);  
driving beam: points HV (percentage of  $E_{max}$ ).
- 6.5.4. If the applicant has indicated more than one mounting position, the procedure of Paragraphs 6.5.1 to 6.5.3 shall be repeated for all the other positions;
- 6.5.5. If the applicant has not asked for special mounting positions, the headlamp shall be aimed for measurements of Paragraphs 6.2 to 6.4 with the headlamps adjusting device in its mean position. The additional tests of Paragraph 6.5.3 shall be made with the reflector moved into its extreme positions (instead of +/- 2 degrees) by means of the headlamps adjusting device.
- 6.6. Measurements of the illumination produced on the screen by the driving beam shall be taken with the same headlamp adjustment as for measurements under 6.3 above, or, in the case of a headlamp providing a driving beam only, in accordance with the final Paragraph of 6.2. In the case where more than one light source is used to provide the main beam, the combined functions shall be used to determine the maximum value of the illumination ( $E_{max}$ ).
- The illumination produced on the screen by the driving beam shall meet the following requirements:
- The point of intersection HV of the lines hh and vv shall be situated within the isolux 90% of maximum illumination. This maximum value shall not less than 32 lux. Starting from point of intersection HV, horizontally to the right and left, illumination shall be not less than 16 lux up to a distance of 1.125 m and not less than 4 lux up to a distance of 2.25 m. (Where the flux of the standard filament lamp used for measurements is other than 700 lumens, the measurements as taken must be corrected proportionally to the ratio of the fluxes.)
- 6.7. The screen illumination values mentioned under 6.3 and 6.5 above shall be measured by means of a photo-electric cell, the useful area of which shall be contained within a square of 65 mm side.
- 7. GAUGING OF DISCOMFORT**
- The discomfort caused by the passing beam of headlamps shall be gauged.<sup>11/</sup>
- 8. STANDARD HEADLAMP**
- A headlamp shall be deemed to be a standard headlamp if it
- 8.1. Satisfies the above-mentioned requirements for approval;
- 8.2. Has an effective diameter of not less than 160 mm;

---

<sup>11/</sup> This requirement will be the subject of a recommendation for the benefit of administrations.

8.3. Provides with a standard filament lamp, at the various points and in the various areas referred to in Paragraph 6.3 above, illumination equal to:

8.3.1. not more than 90% of the maximum limits, and

8.3.2. not less than 120% of the minimum limits prescribed in the Table in Paragraph 6.3.

## **9. CONFORMITY OF PRODUCTION**

9.1 Headlamps approved under this Regulation shall be so manufactured as to conform to the type approved by meeting the requirements set forth in paragraphs 6.

9.2. In order to verify that the requirements of paragraph 9.1. are met, suitable controls of the production shall be carried out.

9.3. The holder of the approval shall in particular:

9.3.1. ensure the existence of procedures for the effective control of the quality of products;

9.3.2. have access to the control equipment necessary for checking the conformity to each approved type;

9.3.3. ensure that data of test results are recorded and that related documents shall remain available for a period to be determined in accordance with the administrative service;

9.3.4. analyze the results of each type of test in order to verify and ensure the stability of the product characteristics making allowance for variation of an industrial production;

9.3.5. ensure that for each type of product at least the tests prescribed in Annex 3 to this Regulation are carried out;

9.3.6. ensure that any collecting of samples giving evidence of non-conformity with the type of test considered shall give rise to another sampling and another test. All the necessary steps shall be taken to re-establish the conformity of the corresponding production.

9.4. The competent authority which has granted type approval may at any time verify the conformity control methods applicable to each production unit.

9.4.1. In every inspection, the test books and production survey records shall be presented to the visiting inspector.

9.4.2. The inspector may take samples at random to be tested in the manufacturer's laboratory. The minimum number of samples may be determined in the light of the results of the manufacturer's own checks.

9.4.3. When the quality level appears unsatisfactory or when it seems necessary to verify the validity of the tests carried out in the application of paragraph 9.4.2. above, the inspector shall select samples, to be sent to the technical service which has conducted the type approval tests, using the criteria of Annex 8.

9.4.4. The competent authority may carry out any test prescribed in this Regulation. These tests will be on samples selected at random without causing distortion of the manufacturer's delivery commitments and in accordance with the criteria of Annex 8.

9.4.5. The competent authority shall strive to obtain a frequency of inspection of once every two years. However, this is at the discretion of the competent authority and their confidence in the arrangements for ensuring effective control of the conformity of production. In the case where negative results are recorded, the competent authority shall ensure that all necessary steps are taken to re-establish the conformity of production as rapidly as possible.

9.5. Headlamps with apparent defects are disregarded.

9.6. The reference mark is disregarded.

## **10. PENALTIES FOR NON CONFORMITY OF PRODUCTION**

10.1. The approval granted in respect of a headlamp pursuant to this Regulation may be withdrawn if the requirements specified above are not met or if a headlamp bearing the approval mark is not in conformity with the type approved.

10.2. If a Contracting Party to the Agreement applying this Regulation withdraws an approval it has previously granted, it shall forthwith so notify the other Contracting Parties applying this Regulation, by means of a communication form conforming to the model in Annex 1 to this Regulation.

## **11. MODIFICATION AND DIMENSION OF APPROVAL OF A TYPE OF HEADLAMP**

11.1. Every modification of the headlamp type shall be notified to the administrative department which approved the type of headlamp. The department may then either:

11.1.1. Consider that the modifications made are unlikely to have an appreciable adverse effect and that in any case that headlamp still complies with the requirements; or

11.1.2. Require a further test report from the technical service responsible for conducting the tests.

11.2. Confirmation or refusal of approval, specifying the alterations, shall be communicated by the procedure specified in Paragraph 4.1.4 above to the Parties to the Agreement applying this Regulation.

11.3. The competent authority issuing the extension of approval shall assign a series number for such an extension and inform thereof the other Parties to the 1958 Agreement applying this Regulation by means of a communication form conforming to the model in Annex 1 to this Regulation.

11.4. Approvals granted before 18 March 1986 remain valid.

## **12. PRODUCTION DEFINITELY DISCONTINUED**

If the holder of the approval completely ceases to manufacture a headlamp approved in accordance with this Regulation, he shall so inform the authority which granted the approval. Upon receiving the relevant communication that authority shall inform thereof the other Parties to the 1958 Agreement applying this Regulation by means of a communication form conforming to the model in Annex 1 to this Regulation.

**13. NAMES AND ADDRESSES OF TECHNICAL SERVICES RESPONSIBLE FOR CONDUCTING APPROVAL TESTS, AND OF ADMINISTRATIVE DEPARTMENTS**

The Parties to the Agreement applying this Regulation shall communicate to the United Nations Secretariat the names and addresses of the technical services responsible for conducting approval tests and of the administrative departments which grant approval and to which forms certifying approval or extension or refusal or withdrawal of approval, issued in other countries, are to be sent.

**Annex 1**

**(Maximum format: A4 (210 x 297 mm))**

**COMMUNICATION**

issued by: Name of administration



Concerning:<sup>2</sup> APPROVAL GRANTED  
APPROVAL EXTENDED  
APPROVAL REFUSED  
APPROVAL WITHDRAWN  
PRODUCTION DEFINITELY DISCONTINUED

of a type of headlamp pursuant to Regulation No. 1

Approval No

Extension No

- Trade name or mark of the device:
2. Manufacturer's name for the type of device:
  3. Manufacturer's name and address:
  4. If applicable, name and address of the manufacturer's representative:
  5. Submitted for approval on:
  6. Technical service responsible for conducting approval tests:
  7. Date of test report:
  8. Number of test report:
  9. Brief description:  
Category as described by the relevant marking:<sup>3</sup>  
Number and category of filament lamp or lamps:  
Colour of light emitted: white/selective yellow<sup>2</sup>
  10. Position of the approval mark:
  11. Reason(s) for extension (if applicable):
  12. Approval granted/extended/refused/withdrawn<sup>2</sup>
  13. Place:
  14. Date:
  15. Signature:
  16. The list of documents deposited with the Administrative Service which has granted approval is annexed to this communication and may be obtained on request.

<sup>1</sup> Distinguishing number of the country which has granted/refused/withdrawn approval (see approval provisions in the Regulation).

<sup>2</sup> Strike out what does not apply.

<sup>3</sup> Indicate the appropriate marking selected from the list below:

CR, CR, CR, C/R, C/R, C, C, C, C/, C/, C/, R CR PL, CR PL, CR PL, C/R PL, C/R PL, C/R PL  
C PL, C PL, C PL, C/PL, C/PL, C/PL, RPL

## Annex 2

### **SPECIAL HEADLAMPS FOR AGRICULTURAL OR FOREST TRACTORS AND OTHER SLOW- MOVING VEHICLES**

The provisions of this Regulation shall also apply to the approval of special headlamps for agricultural or forest tractors and other slow-moving vehicles, such headlamps being intended to provide both a driving beam and a passing beam and having a diameter D or less than 160 mm, 1/ with the following modifications:

- (a) The minimum requirements for illumination laid down in Paragraph 6.3 shall be reduced in the ratio

$$\left[ \frac{D - 45}{160 - 45} \right]^2$$

subject to the following absolute lower limits: 3 lux at either point 75 R or point 75 L;

5 lux at either point 50 R or point 50 L;

1.5 lux in zone IV;

- (b) Instead of the symbol CR provided for in Paragraph 4.2.2.5 of the Regulation, the headlamp shall be marked with the letter M in a downward-pointing triangle;
- (c) In the communication concerning approval, Item 9 in Annex 1 shall read: "Headlamp for slow-moving vehicles only".

### Annex 3

## MINIMUM REQUIREMENTS FOR CONFORMITY OF PRODUCTION CONTROL PROCEDURES

### 1. GENERAL

- 1.1. The conformity requirements shall be considered satisfied from a mechanical and geometric standpoint, if the differences do not exceed inevitable manufacturing deviations within the requirements of this Regulation.
- 1.2. With respect to photometric performances, the conformity of mass-produced headlamps shall not be contested if, when testing photometric performances of any headlamp chosen at random and equipped with a standard filament lamp:
- 1.2.1. no measured value deviates unfavourably by more than 20% from the values prescribed in this Regulation. For values B 50 L (or R) and zone III, the maximum unfavourable deviation may be respectively:
- |                                       |     |
|---------------------------------------|-----|
| B 50 L (or R): 0.2 litersx equivalent | 20% |
| 0.2 liters x equivalent               | 30% |
| Zone III: 0.3 litersx equivalent      | 20% |
| 0.45 litersx equivalent               | 30% |
- 1.2.2. or if
- 1.2.2.1. for the passing beam, the values prescribed in this Regulation are met at HV (with a tolerance of + 0.2 litersx) and related to that aiming at least one point of each area delimited on the measuring screen (at 25 m) by a circle 15 cm in radius around points B 50 L (or R)<sup>1/</sup> (with a tolerance of + 0.1 litersx), 75 R (or L), 25 R, 25 L, and in the entire area of zone IV which is not more than 22.5 cm above line 25 R and 25 L;
- 1.2.2.2. and if, for the driving beam, HV being situated within the isolux 0.75 E<sub>max</sub>, a tolerance of + 20% for maximum values and - 20% for minimum values is observed for the photometric values at any measuring point specified in paragraph 6.6. of this Regulation.
- 1.2.3. If the results of the tests described above do not meet the requirements, the alignment of the headlamp may be changed, provided that the axis of the beam is not displaced laterally by more than 1 degrees to the right or left<sup>9/</sup>.
- 1.2.4. If the results of the tests described above do not meet the requirements, tests on the headlamps shall be repeated using another standard filament lamp.
- 1.3. With respect to the verification of the change in vertical position of the cut-off line under the influence of heat, the following procedure shall be applied:  
One of the sampled headlamps shall be tested according to the procedure described in paragraph 2.1. of Annex 4 after being subjected three consecutive times to the cycle described in paragraph 2.2.2. of Annex 4.

<sup>1/</sup> Letters in brackets refer to headlamps intended for left-hand traffic.

<sup>9/</sup> See the corresponding footnote in the text of the Regulation.

The headlamp shall be considered as acceptable if  $\delta r$  does not exceed 1.5 mrad.

If this value exceeds 1.5 mrad but is not more than 2.0 mrad, a second headlamp shall be subjected to the test after which the mean of the absolute values recorded on both samples shall not exceed 1.5 mrad.

- 1.4. The chromaticity coordinates shall be complied with.

The photometric performance of a headlamp emitting selective yellow light shall be the values contained in this Regulation multiplied by 0.84.

## 2. **MINIMUM REQUIREMENTS FOR VERIFICATION OF CONFORMITY BY THE MANUFACTURER**

For each type of headlamp the holder of the approval mark shall carry out at least the following test, at appropriate intervals. The tests shall be carried out in accordance with the provisions of this Regulation.

If any sampling shows non-conformity with regard to the type of test concerned, further samples shall be taken and tested. The manufacturer shall take steps to ensure the conformity of the production concerned.

### 2.1. Nature of tests

Tests of conformity in this Regulation shall cover the photometric characteristics and the verification of the change in vertical position of the cut-off line under the influence of heat.

### 2.2. Methods used in tests

- 2.2.1. Tests shall generally be carried out in accordance with the methods set out in this Regulation.
- 2.2.2. In any test of conformity carried out by the manufacturer, equivalent methods may be used with the consent of the competent authority responsible for approval tests. The manufacturer is responsible for proving that the applied methods are equivalent to those laid down in this Regulation.
- 2.2.3. The application of paragraphs 2.2.1. and 2.2.2. requires regular calibration of test apparatus and its correlation with measurements made by competent authority.
- 2.2.4. In all cases the reference methods shall be those of this Regulation, particularly for the purpose of administrative verification and sampling.

### 2.3. Nature of sampling

Samples of headlamps shall be selected at random from the production of a uniform batch. A uniform batch means a set of headlamps of the same type, defined according to the production methods of the manufacturer.

The assessment shall in general cover series production from individual factories. However, a manufacturer may group together records concerning the same type from several factories, provided these operate under the same quality system and quality management.

2.4. Measured and recorded photometric characteristics

The sampled headlamp shall be subjected to photometric measurements at the points provided for in the Regulation, the reading being limited to points  $E_{\max}$ , HV<sup>1/</sup>, HL, HR<sup>2/</sup>

in the case of the driving beam, and to points B 50 L (or R), HV, 75 R (or L) and 25 L (or R) in the case of the passing beam (see figure in Annex 6).

2.5. Criteria governing acceptability

The manufacturer is responsible for carrying out a statistical study of the test results and for defining, in agreement with the competent authority, criteria governing the acceptability of his products in order to meet the specifications laid down for verification of conformity of products in paragraph 9.1. of this Regulation.

The criteria governing the acceptability shall be such that, with a confidence level of 95%, the minimum probability of passing a spot check in accordance with Annex 8 (first sampling) would be 0.95.

---

<sup>1/</sup> When the driving beam is reciprocally incorporated with the passing beam, HV in the case of the driving beam shall be the same measuring point as in the case of the passing beam.

<sup>2/</sup> HL and HR: points on "hh" located at 1.125 m to the left and to the right of point HV respectively.

## Annex 4

### TESTS FOR STABILITY OF PHOTOMETRIC PERFORMANCE OF HEADLAMPS IN OPERATION TEST ON COMPLETE HEADLAMPS

Once the photometric values have been measured according to the prescriptions of this Regulation, in points for  $E_{\max}$  for driving beam and HV, 50 R, B 50 L for passing beam (or HV, 50 L, B 50 R for headlamps designed for left-hand traffic) a complete headlamp sample shall be tested for stability of photometric performance in operation. "Complete headlamp" shall be understood to mean the complete lamp itself including those surrounding body parts and lamps which could influence its thermal dissipation.

#### 1. TEST FOR STABILITY OF PHOTOMETRIC PERFORMANCE

The tests shall be carried out in a dry and still atmosphere at an ambient temperature of 23 degrees C +/- 5 degrees C, the complete headlamp being mounted on a base representing the correct installation on the vehicle.

##### 1.1. Clean headlamp

The headlamp shall be operated for 12 hours as described in Subparagraph 1.1.1 and checked as prescribed in Subparagraph 1.1.2.

##### 1.1.1. Test procedure

The headlamp shall be operated for the specified time so that:

- 1.1.1.1. (a) In the case where only one lighting function (driving or passing beam) is to be approved, the corresponding filament is lit for the prescribed time, 1/  
(b) In the case of a reciprocally incorporated passing lamp and driving lamp (dual filament lamp or two filament lamps):

If the applicant declares that the headlamp is to be used with a single filament lit <sup>2/</sup> at a time, the test shall be carried out in accordance with this condition, activating <sup>1/</sup> each specified function successively for half the time specified in Paragraph 1.1,

In all other cases, 1/2/ the headlamp shall be subjected to the following cycle until the time specified is reached:

15 minutes, passing beam filament lit

5 minutes, all filaments lit.

- (c) In the case of grouped lighting functions all the individual functions shall be lit simultaneously for the time specified for individual lighting functions (a) also taking into account the use of reciprocally incorporated lighting functions (b), according to the manufacturer's specifications.

##### 1.1.1.2. Test voltage

The voltage shall be adjusted so as to supply a wattage 15% higher than the rated wattage specified in the Regulation for filament lamps (Regulation No. 37) at a

---

<sup>2/</sup> Should two or more lamp filaments be simultaneously lit when headlamp flashing is used, this shall not be considered as being normal use of the filaments simultaneously.

<sup>1/</sup> When the tested headlamp is grouped and/or reciprocally incorporated with signalling lamps, the latter shall be lit for the duration of the test. In the case of a direction indicator lamp, it shall be lit in flashing operation mode with an on/off time ratio of approximately one to one.

rated voltage of 6 V or 12 V, and 26% higher than the rated wattage for 24 V filament lamps.

The applied wattage shall in all cases comply with the corresponding value of a filament lamp of 12 V rated voltage, except if the applicant for approval specifies that the headlamp may be used at a different voltage. In the latter case, the test shall be carried out with the filament lamp whose wattage is the highest that can be used.

1.1.2. Test Results

1.1.2.1. Visual inspection

Once the headlamp has been stabilized to the ambient temperature, the headlamp lens and the external lens, if any, shall be cleaned with a clean, damp cotton cloth. It shall then be inspected visually, no distortion, deformation, cracking or change in colour of either the headlamp lens or the external lens, if any, shall be noticeable.

1.1.2.2. Photometric test

To comply with the requirements of this Regulation, the photometric values shall be verified in the following points:

Passing beam:

50 R - B 50 L - HV for headlamps designed for right-hand traffic

50 L - B 50 R - HV for headlamps designed for left-hand traffic

Driving beam:

Point of  $E_{max}$

Another aiming may be carried out to allow for any deformation of the headlamp base due to heat (the change of the position of the cut-off line is covered in Paragraph 2 of this Annex). A 10% discrepancy between the photometric characteristics and the values measured prior to the test is permissible including the tolerances of the photometric procedure.

1.2. Dirty headlamp

After being tested as specified in Paragraph 1.1 above, the headlamp shall be operated for one hour as described in Paragraph 1.1.1, after being prepared as prescribed in Paragraph 1.2.1, and checked as prescribed in Subparagraph 1.1.2.

1.2.1. Preparation of the headlamp

1.2.1.1. Test mixture

1.2.1.1.1. For headlamp with the outside lens in glass:

The mixture of water and a polluting agent to be applied to the headlamp shall be composed of:

9 parts by weight of silica sand with a particle size of 0-100  $\mu\text{m}$ ,

1 part by weight of vegetal carbon dust (beechwood) with a particle size of 0-100  $\mu\text{m}$ , 0.2 parts by weight of NaCMC 3/, and

an appropriate quantity of distilled water, with a conductivity of  $< 1 \text{ mS/m}$ .

The mixture must not be more than 14 days old.

1.2.1.1.2. For headlamp with outside lens in plastic material:

The mixture of water and polluting agent to be applied to the headlamp shall be composed of:

9 parts by weight of silica sand with a particle size of 0-100  $\mu\text{m}$ ,

1 part by weight of vegetal carbon dust (beechwood) with a particle size of 0-100  $\mu\text{m}$ , 0.2 part by weight of NaCMC <sup>3/</sup>,

13 parts by weight of distilled water with a conductivity of < 1 mS/m, and

2 +/- 1 parts by weight of surface-actant. <sup>4/</sup>

The mixture must not be more than 14 days old.

1.2.1.2. Application of the test mixture to the headlamp

The test mixture shall be uniformly applied to the entire light emitting surface of the headlamp and then left to dry. This procedure shall be repeated until the illumination value has dropped to 15-20% of the values measured for each following point under the conditions described in this Annex:

Point of  $E_{\text{max}}$  in driving beam photometric distribution for a driving/passing lamp.  
Point of  $E_{\text{max}}$  in driving beam photometric distribution for a driving lamp only.

50 R and 50 V <sup>5/</sup> for a passing lamp only, designed for right-hand traffic.

50 L and 50 V <sup>5/</sup> for a passing lamp only, designed for left-hand traffic.

1.2.1.3. Measuring equipment

The measuring equipment shall be equivalent to that used during headlamp approval tests. A standard (reference) filament lamp shall be used for the photometric verification.

**2. TEST FOR CHANGE IN VERTICAL POSITION OF THE CUT-OFF LINE UNDER THE INFLUENCE OF HEAT**

This test consists of verifying that the vertical drift of the cut-off line under the influence of heat does not exceed a specified value for an operating passing lamp.

The headlamp tested in accordance with Paragraph 1 of this Annex shall be subjected to the test described in Paragraph 2.1 of this Annex, without being removed from or readjusted in relation to its test fixture.

2.1. Test

The test shall be carried out in a dry and still atmosphere at an ambient temperature of 23 degrees C +/- 5 degrees C.

Using a mass production filament lamp which has been aged for at least one hour the headlamp shall be operated on passing beam without being dismantled from

---

<sup>3/</sup> NaCMC represents the sodium salt of carboxymethyl cellulose, customarily referred to as CMC. The NaCMC used in the dirt mixture shall have a degree of substitution (DS) of 0.6-0.7 and a viscosity of 200-300 cP for a 2 % solution at 20 degrees C.

<sup>4/</sup> The tolerance on quantity is due to the necessity of obtaining a dirt that correctly spreads out on all the plastic lens.

<sup>5/</sup> 50 V is situated 375 mm below HV on the vertical line v-v on the screen at 25 m distance.

or readjusted in relation to its test fixture. (For the purpose of this test, the voltage shall be adjusted as specified in Paragraph 1.1.1.2 of this Annex). The position of the cut-off line in its horizontal part (between vv and the vertical line passing through point B 50 L for right-hand traffic or B 50 R for left-hand traffic) shall be verified 3 minutes (r3) and 60 minutes (r60) respectively after operation.

The measurement of the variation in the cut-off line position as described above shall be carried out by any method giving acceptable accuracy and reproducible results.

## 2.2. Test results

2.2.1. The result expressed in milliradians (mrad) shall be considered as acceptable when the absolute value  $\Delta r_I = (r_3 - r_{60})$  recorded on the headlamp is not more than 1.0 mrad ( $\Delta r_I < 1.0 \text{ mrad}$ ).

2.2.2. However, if this value is more than 1.0 mrad but not more than 1.5 mrad ( $1.0 \text{ mrad} < \Delta r_I < 1.5 \text{ mrad}$ ) a second headlamp shall be tested as described in Paragraph 2.1 of this Annex after being subjected three consecutive times to the cycle as described below, in order to stabilize the position of mechanical parts of the headlamp on a base representative of the correct installation on the vehicle:

Operation of the passing lamp for one hour (the voltage shall be adjusted as specified in Paragraph 1.1.1.2 above).

Period of rest for one hour.

The headlamp type shall be considered as acceptable if the mean value of the absolute values  $\Delta r_I$  measured on the first sample and  $\Delta r_{II}$  measured on the second sample is not more than 1.0 mrad.

$$\frac{(\Delta r_I + \Delta r_{II})}{2} \leq 1.0 \text{ mrad}$$

**Annex 5**

**EXAMPLES OF ARRANGEMENTS OF APPROVAL MARKS**

(See Paragraph 4 of this Regulation)

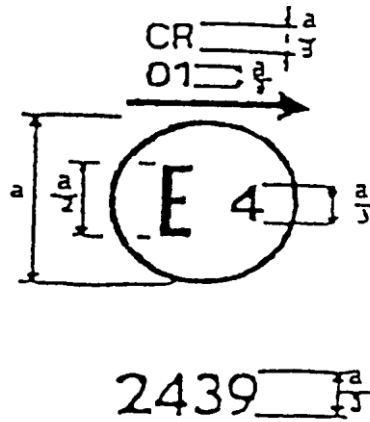

$a = 12 \text{ mm min}$

**Figure 1**

The headlamp bearing the approval marking shown above is a headlamp meeting the requirements of this Regulation in respect of both the driving beam and the passing beam, and which is designed for right-hand traffic only.

Note:

The approval number and the additional symbols shall be placed close to the circle and either above or below the letter "E", or to the right or left of that letter. The digits of the approval number shall be on the same side of the letter "E" and face the same direction.

The use of Roman numerals as approval numbers should be avoided so as to prevent any confusion with other symbols.

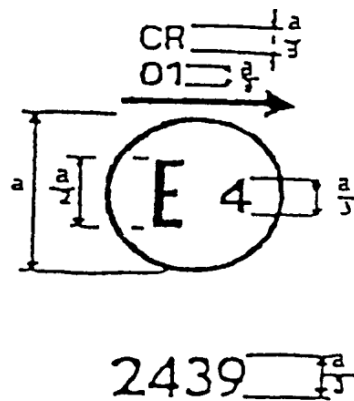

$a = 12 \text{ mm min}$

**Figure 2**

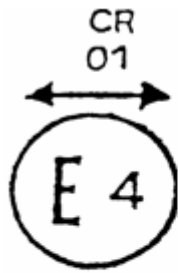

2439  
Figure 3a

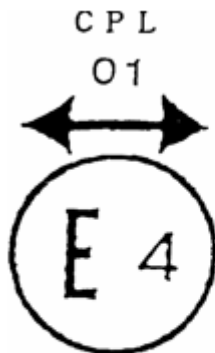

Figure 3b

The headlamp bearing the approval mark shown above is a headlamp meeting the requirements of this Regulation with respect to both the passing beam and the driving beam, and designed:

Figure 2 = For left hand traffic only

Figure 3a, 3b = For both traffic systems, by means of an adjustment as desired of the optical unit or the lamp.



2439  
Figure 4

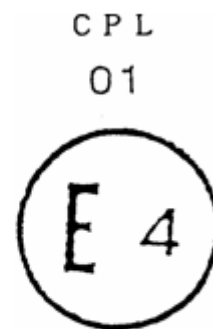

2439  
Figure 5

The headlamp bearing the approval mark shown above is a headlamp incorporating the lens of plastic material meeting the requirements of this Regulation with respect to the passing beam only, and designed:

Figure 4 = For both traffic systems.

Figure 5 = For right-hand traffic only.

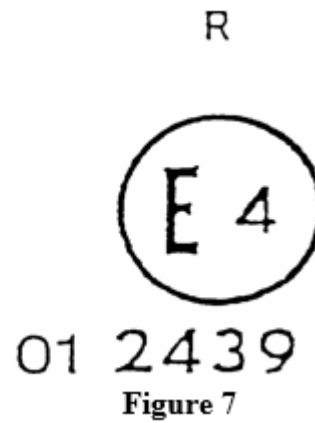
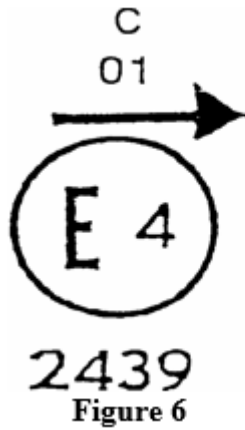

The headlamp bearing the approval mark shown above is a headlamp meeting the requirements of this Regulation:

Figure 6 = With respect to the passing beam only, and designed for left-hand traffic only.

Figure 7 = With respect to the driving beam only.

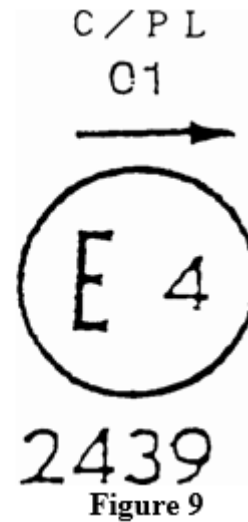

Identification of a headlamp incorporating the lens of plastic material meeting the requirements of Regulation No. 1:

Figure 8 = For both the passing beam and the driving beam and designed for right-hand traffic only.

Figure 9 = For the passing beam only and designed for left-hand traffic only.

The passing lamp filament shall not be lit simultaneously with the driving lamp filament and/or any other headlamp with which it is reciprocally incorporated.

**Simplified marking of grouped, combined or reciprocally incorporated lamps**  
**Figure 10**  
 (The vertical and horizontal lines schematize the shape of the light-signalling device.  
 They are not part of the approval mark.)

**Model A**

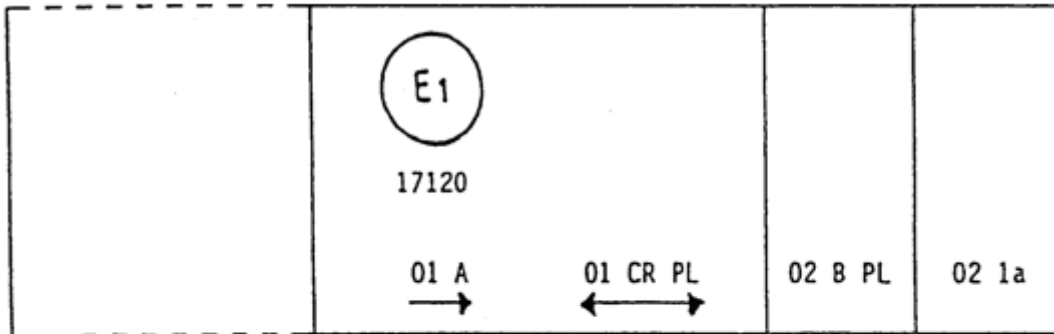

**Model B**

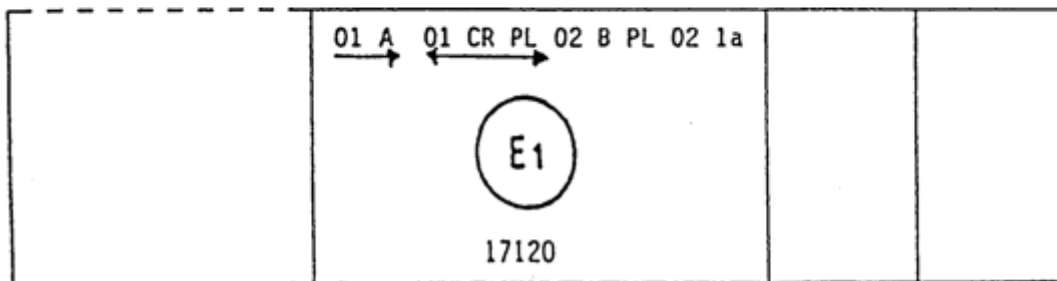

**Model C**

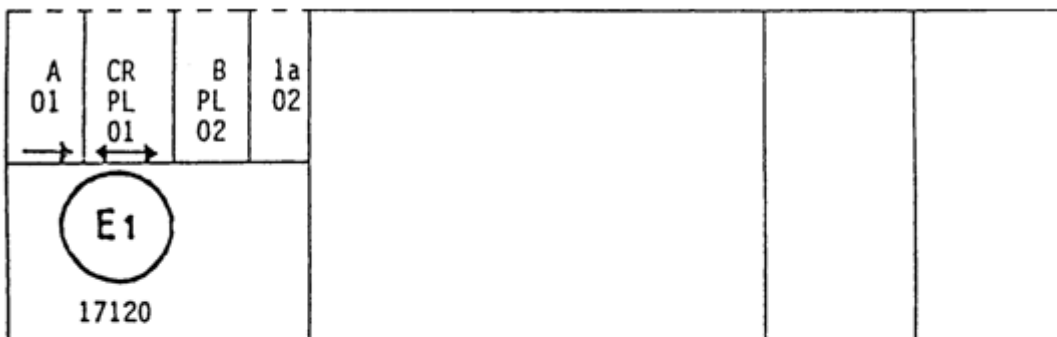

**Model D**

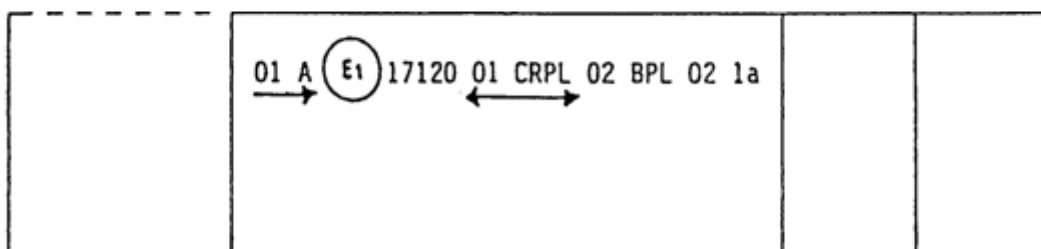

Note:

The four examples shown above correspond to a lighting device bearing an approval mark relating to:

A front position lamp approved in accordance with the 01 series of amendments to Regulation No. 7,

A headlamp with a passing beam designed for right-hand and left-hand traffic and a driving beam, approved in accordance with the 01 series of amendments to Regulation No. 1 and incorporating a lens of plastic material;

A front fog lamp approved in accordance with the 02 series of amendments to Regulation No. 19 and incorporating a lens of plastic material;

A front direction indicator lamp of category 1a approved in accordance with the 02 series of amendments to Regulation No. 6.

**Figure 11**  
**Lamp reciprocally incorporated with a headlamp**

**Example 1**

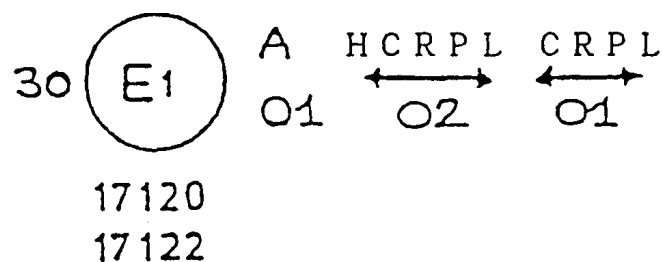

The above example corresponds to the marking of a lens of plastic material intended to be used in different types of headlamps, namely:

either: a headlamp with a passing beam designed for right-hand and left-hand traffic and a driving beam with a maximum intensity comprised between 86,250 and 101,250 candelas, approved in the Federal Republic of Germany (E1) in accordance with the requirements of Regulation No. 20 as amended by the 02 series of amendments, which is reciprocally incorporated with a front position lamp approved in accordance with the 01 series of amendments to Regulation No. 7;

or: a headlamp with a passing beam designed for right-hand and left-hand traffic and a driving beam, approved in the Federal Republic of Germany (E1) in accordance with the requirements of Regulation No. 1 as amended by the 01 series of amendments, which is reciprocally incorporated with the same front position lamp as above;

or even: either of the above-mentioned headlamps approved as a single lamp.

The main body of the headlamp shall bear the only valid approval number, for instance:

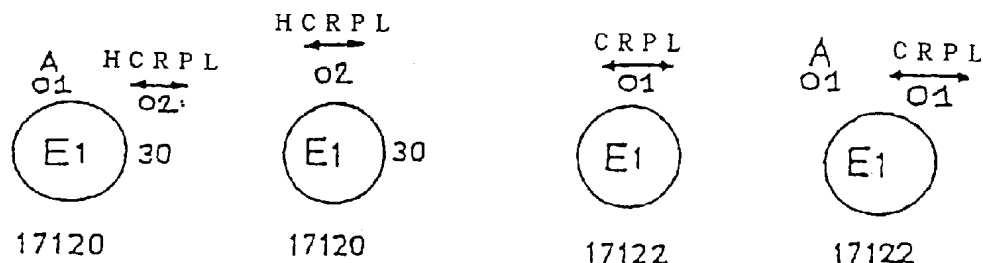

### Example 2

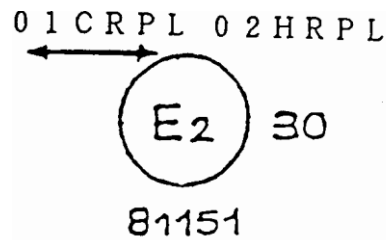

The above example corresponds to the marking of a lens of plastic material used in a unit of two headlamps approved in France (E2), consisting of a headlamp emitting a passing beam designed for both traffic systems and of a driving beam with a maximum intensity comprised between x and y candelas, meeting the requirements of Regulation No. 1, as amended by the 01 series of amendments and of a headlamp emitting a driving beam with a maximum intensity comprised between w and z candelas, meeting the requirements of Regulation No. 20, as amended by the 02 series of amendments the maximum intensity of all the driving beams being comprised between 86,250 and 101,250 candelas.

**Annex 6**  
**MEASURING SCREENS**

**A. Headlamp for right-hand traffic (Dimensions in mm)**

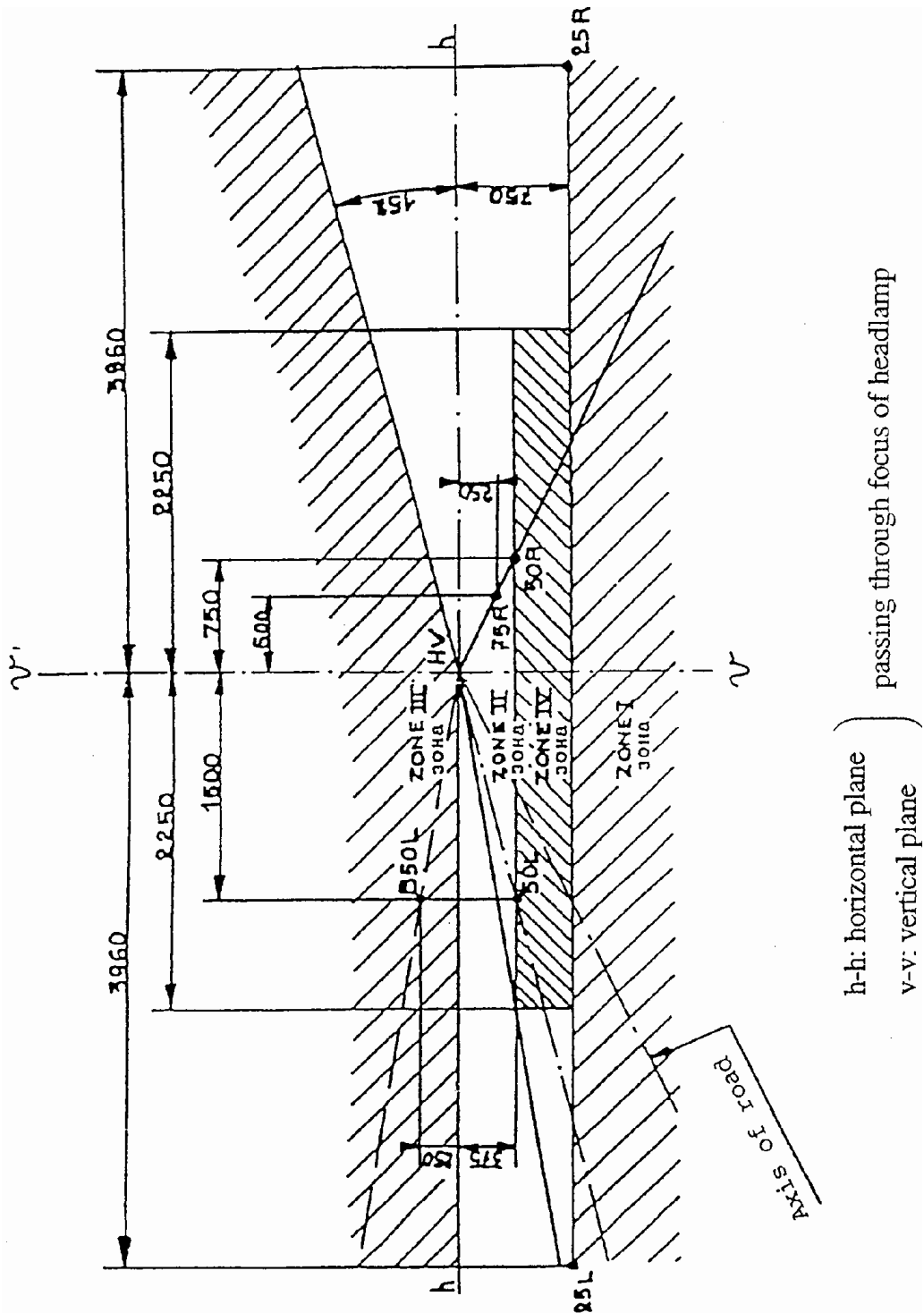

h-h : horizontal plane  
 v-v : vertical plane

Passing through focus of headlamp



## STANDARD EUROPEAN BEAM

### C. Measuring points of illumination values

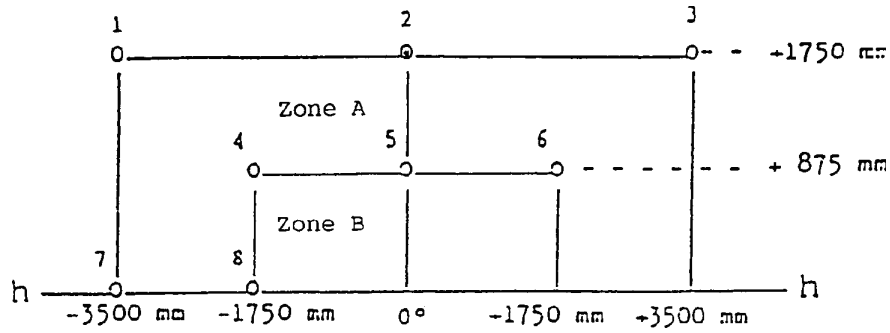

Note:

Figure P1C shows the measuring points for right-hand traffic.

Points 7 and 8 move to their corresponding location at the right-hand side of the picture for left-hand traffic.

## Annex 7

### REQUIREMENTS FOR LAMPS INCORPORATING LENSES OF PLASTIC MATERIAL- TESTING OF LENS OR MATERIAL SAMPLES AND OF COMPLETE LAMPS

#### 1. GENERAL SPECIFICATIONS

- 1.1. The samples supplied pursuant to paragraph 2.2.4 of this Regulation shall satisfy the specifications indicated in paragraphs 2.1 to 2.5 below.
- 1.2. The two samples of complete lamps supplied pursuant to paragraph 2.2.3 of this Regulation and incorporating lenses of plastic material shall, with regard to the lens material, satisfy the specifications indicated in paragraph 2.6 below.
- 1.3. The samples of lenses of plastic material or samples of material shall be subjected, with the reflector to which they are intended to be fitted (where applicable), to approval tests in the chronological order indicated in Table A reproduced in Appendix 1 to this Annex.
- 1.4. However, if the lamp manufacturer can prove that the product has already passed the tests prescribed in Paragraphs 2.1-2.5 below, or the equivalent tests pursuant to another Regulation, those tests need not be repeated; only the tests prescribed in Appendix 1, Table B, shall be mandatory.

#### 2. TESTS

##### 2.1. Resistance to temperature changes

##### 2.1.1. Tests

Three new samples (lenses) shall be subjected to five cycles of temperature and humidity (RH = relative humidity) change in accordance with the following programme: 3 hours at 40 degrees C +/- 2 degrees C and 85-95% RH;

1 hour at 23 degrees C +/- 5 degrees C and 60-75% RH;

15 hours at -30 degrees C +/- 2 degrees C;

1 hour at 23 degrees C +/- 5 degrees C and 60-75% RH;

3 hours at 80 degrees C +/- 2 degrees C;

1 hour at 23 degrees C +/- 5 degrees C and 60-75% RH;

Before this test, the samples shall be kept at 23 degrees C +/- 5 degrees C and 60-75% RH for at least four hours.

##### Note:

The periods of one hour at 23 degrees C +/- 5 degrees C shall include the periods of transition from one temperature to another which are needed in order to avoid thermal shock effects.

##### 2.1.2. Photometric measurements

##### 2.1.2.1. Method

Photometric measurements shall be carried out on the samples before and after the test. These measurements shall be made using a standard lamp, at the following points:

B 50 L and 50 R for the passing beam of a passing lamp or a passing/driving lamp (B 50 R and 50 L in the case of headlamps intended for left-hand traffic);

$E_{\max}$  route for the driving beam of a driving lamp or a passing/driving lamp;

#### 2.1.2.2. Results

The variation between the photometric values measured on each sample before and after the test shall not exceed 10% including the tolerances of the photometric procedure.

### 2.2. Resistance to atmospheric and chemical agents

#### 2.2.1. Resistance to atmospheric agents

Three new samples (lenses or samples of material) shall be exposed to radiation from a source having a spectral energy distribution similar to that of a black body at a temperature between 5,500K and 6,000K. Appropriate filters shall be placed between the source and the samples so as to reduce as far as possible radiations with wave lengths smaller than 295 nm and greater than 2,500 nm. The samples shall be exposed to an energetic illumination of 1,200 W/m<sup>2</sup> +/- 200 W/m<sup>2</sup> for a period such that the luminous energy that they receive is equal to 4,500 MJ/m<sup>2</sup> +/- 200 MJ/m<sup>2</sup>. Within the enclosure, the temperature measured on the black panel placed on a level with the samples shall be 50 degrees C +/- 5 degrees C. In order to ensure a regular exposure, the samples shall revolve around the source of radiation at a speed between 1 and 5 l/min.

The samples shall be sprayed with distilled water of conductivity lower than 1 mS/m at a temperature of 23 degrees C +/- 5 degrees C, in accordance with the following cycle: spraying:5 minutes;

drying:25 minutes;

#### 2.2.2. Resistance to chemical agents

After the test described in Paragraph 2.2.1 above and the measurement described in Paragraph 2.2.3.1 below have been carried out, the outer face of the said three samples shall be treated as described in Paragraph 2.2.2.2 with the mixture defined in Paragraph 2.2.2.1 below.

##### 2.2.2.1. Test mixture

The test mixture shall be composed of 61.5% n-heptane, 12.5% toluene, 7.5% ethyl tetrachloride, 12.5% trichlorethylene and 6% xylene (volume%).

##### 2.2.2.2. Application of the test mixture

Soak a piece of cotton cloth (as per ISO 105) until saturation with the mixture defined in Paragraph 2.2.2.1 above and, within 10 seconds, apply it for 10 minutes to the outer face of the sample at a pressure of 50 N/cm<sup>2</sup>, corresponding to an effort of 100 N applied on a test surface of 14 x 14 mm.

During this 10-minute period, the cloth pad shall be soaked again with the mixture so that the composition of the liquid applied is continuously identical with that of the test mixture prescribed.

During the period of application, it is permissible to compensate the pressure applied to the sample in order to prevent it from causing cracks.

### 2.2.2.3. Cleaning

At the end of the application of the test mixture, the samples shall be dried in the open air and then washed with the solution described in paragraph 2.3 (Resistance to detergents) at 23 degrees C +/- 5 degrees C.

Afterwards the samples shall be carefully rinsed with distilled water containing not more than 0.2% impurities at 23 degrees C +/- 5 degrees C and then wiped off with a soft cloth.

### 2.2.3. Results

2.2.3.1. After the test of resistance to atmospheric agents, the outer face of the samples shall be free from cracks, scratches, chipping and deformation, and the mean variation in transmission

$$\Delta t = \frac{T_2 - T_3}{T_2}, \left| \right.$$

measured on the three samples according to the procedure described in Appendix 2 to this Annex shall not exceed 0.020 (  $\epsilon_{\lambda} \text{atm} < 0.020$  ).

2.2.3.2. After the test of resistance to chemical agents, the samples shall not bear any traces of chemical staining likely to cause a variation of flux diffusion, whose mean variation

$$\Delta d = \frac{T_5 - T_4}{T_2}, \left| \right.$$

measured on the three samples according to the procedure described in Appendix 2 to this Annex shall not exceed 0.020 (  $\epsilon_{\lambda} \text{adm} < 0.020$  ).

## 2.3. Resistance to detergents and hydrocarbons

### 2.3.1. Resistance to detergents

The outer face of three samples (lenses or samples of material) shall be heated to 50 degrees C +/- 5 degrees C and then immersed for five minutes in a mixture maintained at 23 degrees C +/- 5 degrees C and composed of 99 parts distilled water containing not more than 0.02% impurities and one part alkylaryl sulphate.

At the end of the test, the samples shall be dried at 50 degrees C +/- 5 degrees C. The surface of the samples shall be cleaned with a moist cloth.

### 2.3.2. Resistance to hydrocarbons

The outer face of these three samples shall then be lightly rubbed for one minute with a cotton cloth soaked in a mixture composed of 70% n-heptane and 30% toluene (volume%), and shall then be dried in the open air.

### 2.3.3. Results

After the above two tests have been performed successively, the mean value of the variation in transmission

$$\Delta t = \frac{T_2 - T_3}{T_2}, \left| \right.$$

measured on the three samples according to the procedure described in Appendix 2 to this Annex shall not exceed 0.010 (  $\epsilon_{\lambda} \text{atm} < 0.010$  ).

## 2.4. Resistance to mechanical deterioration

### 2.4.1. Mechanical deterioration method

The outer face of the three new samples (lenses) shall be subjected to the uniform mechanical deterioration test by the method described in Appendix 3 to this Annex.

### 2.4.2. Results

After this test, the variations;

in transmission:  $\Delta t = \frac{T_2 - T_3}{T_2}$ ,

$$\left. \Delta t = \frac{T_2 - T_3}{T_2}, \right|$$

and in diffusion:  $\Delta d = \frac{T_5 - T_4}{T_2}$ ,

$$\left. \Delta d = \frac{T_5 - T_4}{T_2}, \right|$$

shall be measured according to the procedure described in Appendix 2 in the area specified in Paragraph 2.2.4 above. The mean value of the three samples shall be such that:

$$\left. \begin{aligned} \Delta t_m &\leq 0.100; \\ \Delta d_m &\leq 0.050. \end{aligned} \right|$$

## 2.5. Test of adherence of coatings, if any

### 2.5.1. Preparation of the sample

A surface of 20 mm x 20 mm in area of the coating of a lens shall be cut with a razor blade or a needle into a grid of squares approximately 2 mm x 2 mm. The pressure on the blade or needle shall be sufficient to cut at least the coating.

### 2.5.2. Description of the test

Use an adhesive tape with a force of adhesion of 2 N/(cm of width) +/- 20% measured under the standardized conditions specified in Appendix 4 to this Annex. This adhesive tape, which shall be at least 25 mm wide, shall be pressed for at least five minutes to the surface prepared as prescribed in Paragraph 2.5.1.

Then the end of the adhesive tape shall be loaded in such a way that the force of adhesion to the surface considered is balanced by a force perpendicular to that surface. At this stage, the tape shall be torn off at a constant speed of 1.5 m/s +/- 0.2 m/s.

### 2.5.3. Results

There shall be no appreciable impairment of the gridded area. Impairments at the intersections between squares or at the edges of the cuts shall be permitted, provided that the impaired area does not exceed 15% of the gridded surface.

## 2.6. Tests of the complete lamp incorporating a lens of plastic material

### 2.6.1. Resistance to mechanical deterioration of the lens surface

#### 2.6.1.1. Tests

The lens of lamp sample No. 1 shall be subjected to the test described in Paragraph 2.4.1 above.

2.6.1.2. Results

After the test, the results of photometric measurements carried out on the lamp in accordance with this Regulation shall not exceed by more than 30% the maximum values prescribed at points B 50 L and HV and not be more than 10% below the minimum values prescribed at point 75 R (in the case of headlamps intended for left-hand traffic, the points to be considered are B 50 R, HV and 75 L).

2.6.2. Test of adherence of coatings, if any

The lens of lamp sample No. 2 shall be subjected to the test described in Paragraph 2.5 above.

**3. VERIFICATION OF THE CONFORMITY OF PRODUCTION**

3.1. With regard to the materials used for the manufacture of lenses, the lamps of a series shall be recognized as complying with this Regulation if:

3.1.1. After the test for resistance to chemical agents and the test for resistance to detergents and hydrocarbons, the outer face of the samples exhibits no cracks, chipping or deformation visible to the naked eye (see Paragraphs 2.2.2, 2.3.1 and 2.3.2);

3.1.2. After the test described in Paragraph 2.6.1.1, the photometric values at the points of measurement considered in Paragraph 2.6.1.2 are within the limits prescribed for conformity of production by this Regulation.

3.2. If the test results fail to satisfy the requirements, the tests shall be repeated on another sample of headlamps selected at random.

**Annex 7 Appendix 1**

**CHRONOLOGICAL ORDER OF APPROVAL TESTS**

**A. Tests on plastic materials (lenses or samples of material supplied pursuant to paragraph 2.2.4. of this Regulation).**

Tests	Samples	Lenses or samples of material						Lenses						
		1	2	3	4	5	6	7	8	9	10	11	12	13
1.1	Limited photometry (para. 2.1.2)										X	X	X	
1.1.1	Temperature change (para. 2.1.1)										X	X	X	
1.1.2	Limited photometry (para. 2.1.2)										X	X	X	
1.2.1	Transmission measurement	X	X	X	X	X	X	X	X	X				
1.2.2	Diffusion measurement	X	X	X				X	X	X				
1.3	Atmospheric agents (para. 2.2.1)	X	X	X										
1.3.1	Transmission measurement	X	X	X										
1.4	Chemicals agents (para. 2.2.2)	X	X	X										
1.4.1	Diffusion measurement	X	X	X										
1.5	Detergents (para. 2.3.1)				X	X	X							
1.6	Hydrocarbons (para. 2.3.2)				X	X	X							
1.6.1	Transmission measurement				X	X	X							
1.7	Deterioration (para. 2.4.1)							X	X	X				
1.7.1	Transmission measurement							X	X	X				
1.7.2	Diffusion measurement							X	X	X				
1.8	Adherence (para. 2.5)													X

**B. Tests on complete lamps (supplied pursuant to paragraph 2.2.3. of his Regulation).**

Tests	Complete lamp	
	Sample No.	
	1	2
2.1 Deterioration (para. 2.6.1.1)	X	
2.2 Photometry (para. 2.6.1.2)	X	
2.3 Adherence (para. 2.6.2)		X

## Annex 7 Appendix 2

### METHOD OF MEASUREMENT OF THE DIFFUSION AND TRANSMISSION OF LIGHT

#### 1. EQUIPMENT (See Figure)

The beam of a collimator K with a half divergence

$$\frac{\beta}{2} = 17.4 \times 10^{-4} \text{ rd}$$

is limited by a diaphragm Dr with an opening of 6mm against which the sample stand is placed. A convergent achromatic lens L<sub>2</sub>, corrected for spherical aberration, links the diaphragm Dr with the receiver R; the diameter of the lens L<sub>2</sub> shall be such that it does not diaphragm the light diffused by the sample in a cone with a half top angle of  $\beta/2 = 14$  degrees .

An annular diaphragm D<sub>D</sub> with angles

$$\frac{\alpha_0}{2} = 1^\circ \text{ and } \frac{\alpha_{\max}}{2} = 12^\circ$$

is placed in an image focal plane of the lens L<sub>2</sub>.

The non-transparent central part of the diaphragm is necessary in order to eliminate the light arriving directly from the light source. It shall be possible to remove the central part of the diaphragm from the light beam in such a manner that it returns exactly to its original position.

The distance L<sub>2</sub> Dr and the focal length F<sub>2</sub><sup>1/</sup> of the lens L<sub>2</sub> shall be so chosen that the image of Dr completely covers the receiver R.

When the initial incident flux is referred to 1,000 units, the absolute precision of each reading shall be better than 1 unit.

#### 2. MEASUREMENTS

The following readings shall be taken:

Reading	With sample	With central part of DD	Quantity represented
T1	no	no	Incident flux in initial reading
T2	yes (before test)	no	Flux transmitted by the new material in a field of 24 degrees C
T3	yes (after test)	no	Flux transmitted by the tested material in a field of 24 degrees C
T4	yes (before test)	yes	Flux diffused by the new material
T5	yes (after test)	yes	Flux diffused by the tested material

<sup>1/</sup> For L<sub>2</sub> it is recommended to use a focal distance of about 80 mm.

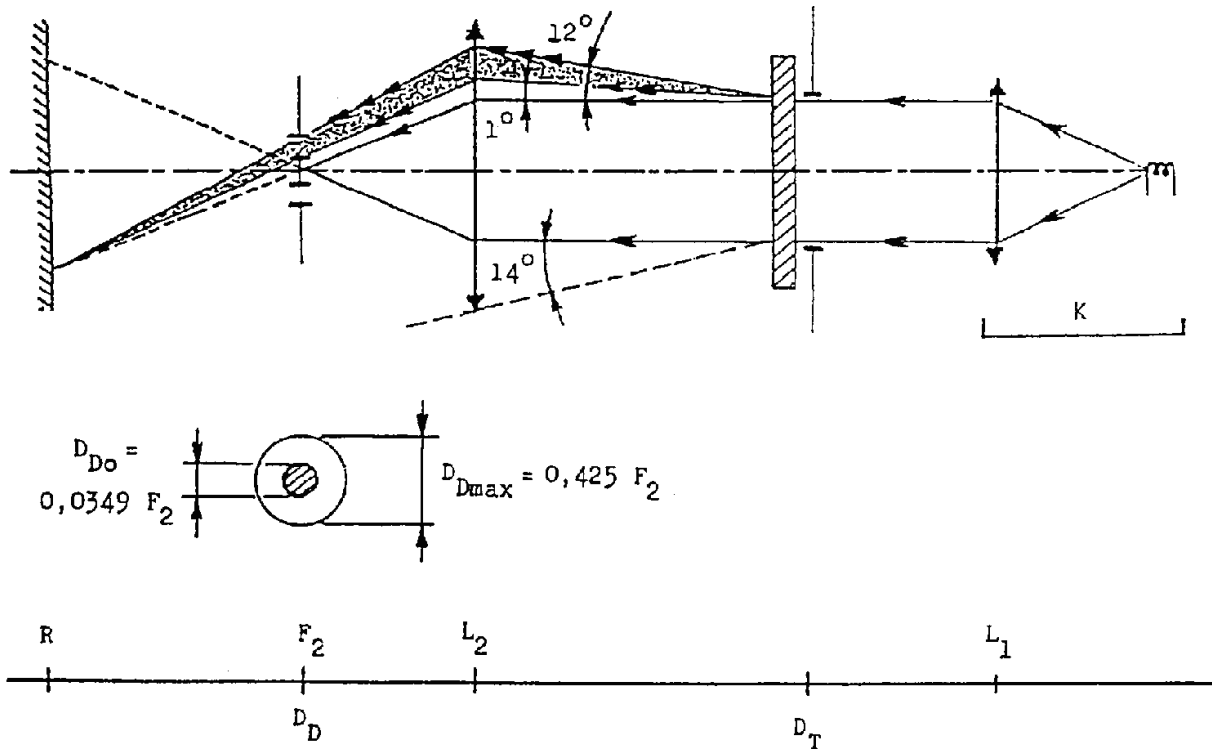

## **Annex 7 – Appendix 3**

### **SPRAY TESTING METHOD**

#### **1. Test Equipment**

##### **1.1. Spray gun**

The spray gun used shall be equipped with a nozzle 1.3 mm in diameter allowing a liquid flow rate of 0.24 +/- 0.02 l/minute at an operating pressure of 6.0 bars -0, +0.5 bar. Under these operation conditions the fan pattern obtained shall be 170 mm +/- 50 mm in diameter on the surface exposed to deterioration, at a distance of 380 mm +/- 10 mm from the nozzle.

##### **1.2. Test mixture**

The test mixture shall be composed of:

Silica sand of hardness 7 on the Mohr scale, with a grain size between 0 and 0.2 mm and an almost normal distribution, with an angular factor of 1.8 to 2;

Water of hardness not exceeding 205 g/m<sup>3</sup> for a mixture comprising 25 g of sand per litre of water.

#### **2. Test**

The outer surface of the lamp lenses shall be subjected once or more than once to the action of the sand jet produced as described above. The jet shall be sprayed almost perpendicular to the surface to be tested.

The deterioration shall be checked by means of one or more samples of glass placed as a reference near the lenses to be tested. The mixture shall be sprayed until the variation in the diffusion of light on the sample or samples measured by the method described in Appendix 2, is such that:

depsilonlambdataua

$$\Delta d = \frac{T5 - T4}{T2} = 0.0250 \pm 0.0025$$

Several reference samples may be used to check that the whole surface to be tested has deteriorated homogeneously.

## **Annex 7 - Appendix 4**

### **ADHESIVE TAPE ADHERENCE TEST**

#### **1. PURPOSE**

This method allows to determine under standard conditions the linear force of adhesion of an adhesive tape to a glass plate.

#### **2. PRINCIPLE**

Measurement of the force necessary to unstick an adhesive tape from a glass plate at an angle of 90 degrees.

#### **3. SPECIFIED ATMOSPHERIC CONDITIONS**

The ambient conditions shall be at 23 degrees C +/- 5 degrees C and 65 degrees C +/- 15% relative humidity (RH).

#### **4. TEST PIECES**

Before the test, the sample roll of adhesive tape shall be conditioned for 24 hours in the specified atmosphere (See Para. 3 above).

Five test pieces each 400 mm long shall be tested from each roll. These test pieces shall be taken from the roll after the first three turns were discarded.

#### **5. PROCEDURE**

The test shall be under the ambient conditions specified in Paragraph 3.

Take the five test pieces while unrolling the tape radially at a speed of approximately 300 mm/s, then apply them within 15 seconds in the following manner:

Apply the tape to the glass plate progressively with a slight length-wise rubbing movement of the finger, without excessive pressure, in such a manner as to leave no air bubble between the tape and the glass plate.

Leave the assembly in the specified atmospheric conditions for 10 minutes.

Unstick about 25 mm of the test piece from the plate in a plane perpendicular to the axis of the test piece.

Fix the plate and fold back the free end of the tape at 90 degrees. Apply force in such a manner that the separation line between the tape and the plate is perpendicular to this force and perpendicular to the plate.

Pull to unstick at a speed of 300 mm/s +/- 30 mm/s and record the force required.

#### **6. RESULTS**

The five values obtained shall be arranged in order and the median value taken as the result of the measurement. This value shall be expressed in Newtons centimetre of width of the tape.

## Annex 8

### MINIMUM REQUIREMENTS FOR SAMPLING BY AN INSPECTOR

#### 1. GENERAL

1.1. The conformity requirements shall be considered satisfied from a mechanical and a geometric standpoint, in accordance with the requirements of this Regulation, if any, if the differences do not exceed inevitable manufacturing deviations.

1.2. With respect to photometric performance, the conformity of mass-produced headlamps shall not be contested if, when testing photometric performances of any headlamp chosen at random and equipped with a standard filament lamp;

1.2.1. no measured value deviates unfavourably by more than 20% from the values prescribed in this Regulation.

For values B 50 L (or R) and Zone III the maximum deviation may be respectively:

B 50 L (or R): 0.2 litersx equivalent 20%

0.3 litersx equivalent 30%

Zone III: 0.3 litersx equivalent 20%

0.45 litersx equivalent 30%

1.2.2. or if

1.2.2.1. for the passing beam, the values prescribed in this Regulation are met at HV (with a tolerance of 0.2 litersx) and related to that aiming at least one point of each area delimited on the measuring screen (at 25 m) by a circle 15 cm in radius around points B 50 L (or R) (with a tolerance of 0.1 litersx), 75 R (or L), 25 R, 25 L, and in the entire area of zone IV which is not more than 22.5 cm above line 25 R and 25 L;

1.2.2.2. and if, for the driving beam, HV being situated within the isolux 0.75 E<sub>max</sub>, a tolerance of +20% for maximum values and -20% for minimum values is observed for the photometric values at any measuring point specified in paragraph 6.6. of this Regulation. The reference mark is disregarded.

1.2.3. If the results of the tests described above do not meet the requirements, the alignment of the headlamp may be changed, provided that the axis of the beam is not displaced laterally by more than 1 degrees to the right or left.<sup>/9</sup>

1.2.4. If the results of the tests described above do not meet the requirements, tests on the headlamp shall be repeated using another standard filament lamp.

1.2.5. Headlamps with apparent defects are disregarded.

1.2.6. The reference mark is disregarded.

1.3. The chromaticity coordinates shall be complied with.

The photometric performance of a headlamp emitting selective yellow light shall be the values contained in this Regulation multiplied by 0.84.

#### 2. FIRST SAMPLING

<sup>/9</sup> See the corresponding footnote in the text of the Regulation.

In the first sampling four headlamps are selected at random. The first sample of two is marked A, the second sample of two is marked B.

2.1. The conformity is not contested

2.1.1. Following the sampling procedure shown in Figure 1 of this Annex the conformity of mass-produced headlamps shall not be contested if the deviation of the measured values of the headlamps in the unfavourable directions are:

2.1.1.1. sample A

A1:	one headlamp		0%
	one headlamp	not more than	20%
A2:	both headlamps	more than	0%
	but not more than		20%

go to sample B

2.1.1.2. sample B

B1:	both headlamps		0%
-----	----------------	--	----

2.1.2. or if the conditions of paragraph 1.2.2. for sample A are fulfilled.

2.2. The conformity is contested

2.2.1. Following the sampling procedure shown in Figure 1 of this Annex the conformity of mass-produced headlamps shall be contested and the manufacturer requested to make his production meet the requirements (alignment) if the deviations of the measured values of the headlamps are:

2.2.1.1. sample A

A3:	one headlamp	not more than	20%
	one headlamp	more than	20%
	but	not more than	30 %

2.2.1.2. sample B

B2:	in the case of A2		
	one headlamp	more than	0%
	but	not more than	20%
	one headlamp	not more than	20%
B3:	in the case of A2		
	one headlamp		0%
	one headlamp	more than	20%
	but	not more than	30%

2.2.2. or if the conditions of paragraph 1.2.2. for sample A are not fulfilled.

2.3. Approval withdrawn

Conformity shall be contested and paragraph 10 applied if, following the sampling procedure in Figure 1 of this Annex, the deviations of the measured values of the headlamps are:

2.3.1. sample A

A4:	one headlamp	not more than	20%
	one headlamp	more than	30%
A5:	both headlamps	more than	20 %

2.3.2. sample B

B4:	in the case of A2		
	one headlamp	more than	0%
	but	not more than	20 %
	one headlamp	more than	20%
B5:	in the case of A2		
	both headlamps	more than	20%
B6:	in the case of A2		
	one headlamp		0 %
	one headlamp	more than	30%

2.3.3. or if the conditions of paragraph 1.2.2. for samples A and B are not fulfilled.

**3. REPEATED SAMPLING**

In the cases of A3, B2, B3 a repeated sampling, third sample C of two headlamps and fourth sample D of two headlamps, selected from stock manufactured after alignment, is necessary within two months' time after the notification.

3.1. The conformity is not contested

3.1.1. Following the sampling procedure shown in Figure 1 of this Annex the conformity of mass-produced headlamps shall not be contested if the deviations of the measured values of the headlamps are:

3.1.1.1. sample C

C1:	one headlamp		0%
	one headlamp	not more than	20%
C2:	both headlamps	more than	0%
	but	not more than	20%

go to sample D

3.1.1.2. sample D

D1:	in the case of C2		
	both headlamps		0%

3.1.2. or if the conditions of paragraph 1.2.2. for sample C are fulfilled.

3.2. The conformity is contested

3.2.1. Following the sampling procedure shown in Figure 1 of this Annex the conformity of mass-produced headlamps shall be contested and the manufacturer requested to make his production meet the requirements (alignment) if the deviations of the measured values of the headlamps are:

3.2.1.1. sample D

D2: in the case of C2

one headlamp	more than	0%
but	not more than	20%
one headlamp	not more than	20%

3.2.1.2. or if the conditions of paragraph 1.2.2. for sample C are not fulfilled:

3.3. Approval withdrawn

Conformity shall be contested and paragraph 10 applied if, following the sampling procedure in Figure 1 of this Annex, the deviations of the measured values of the headlamps are:

3.3.1. sample C

C3: one headlamp	not more than	20%
one headlamp	more than	20%
C4: both headlamps	more than	20%

3.3.2. sample D

D3: in the case of C2

one headlamp	0 or more than	0%
one headlamp	more than	20%

3.3.3. or if the conditions of paragraph 1.2.2. for samples C and D are not fulfilled.

**4. CHANGE OF THE VERTICAL POSITION OF THE CUT-OFF LINE**

With respect to the verification of the change in vertical positions of the cut-off line under the influence of heat, the following procedure shall be applied:

One of the headlamps of sample A after sampling procedure in Figure 1 of this Annex shall be tested according to the procedure described in paragraph 2.1. of Annex 4 after being subjected three consecutive times to the cycle described in paragraph 2.2.2. of Annex 4.

The headlamp shall be considered as acceptable if  $\Delta r$  does not exceed 1.5 mrad.

If this value exceeds 1.5 mrad but is not more than 2.0 mrad, the second headlamp of sample A shall be subjected to the test after which the mean of the absolute values recorded in both samples shall not exceed 1.5 mrad.

However, if this value of 1.5 mrad on sample A is not complied with, the two headlamps of sample B shall be subjected to the same procedure and the value of delta r for each of them shall not exceed 1.5 mrad.

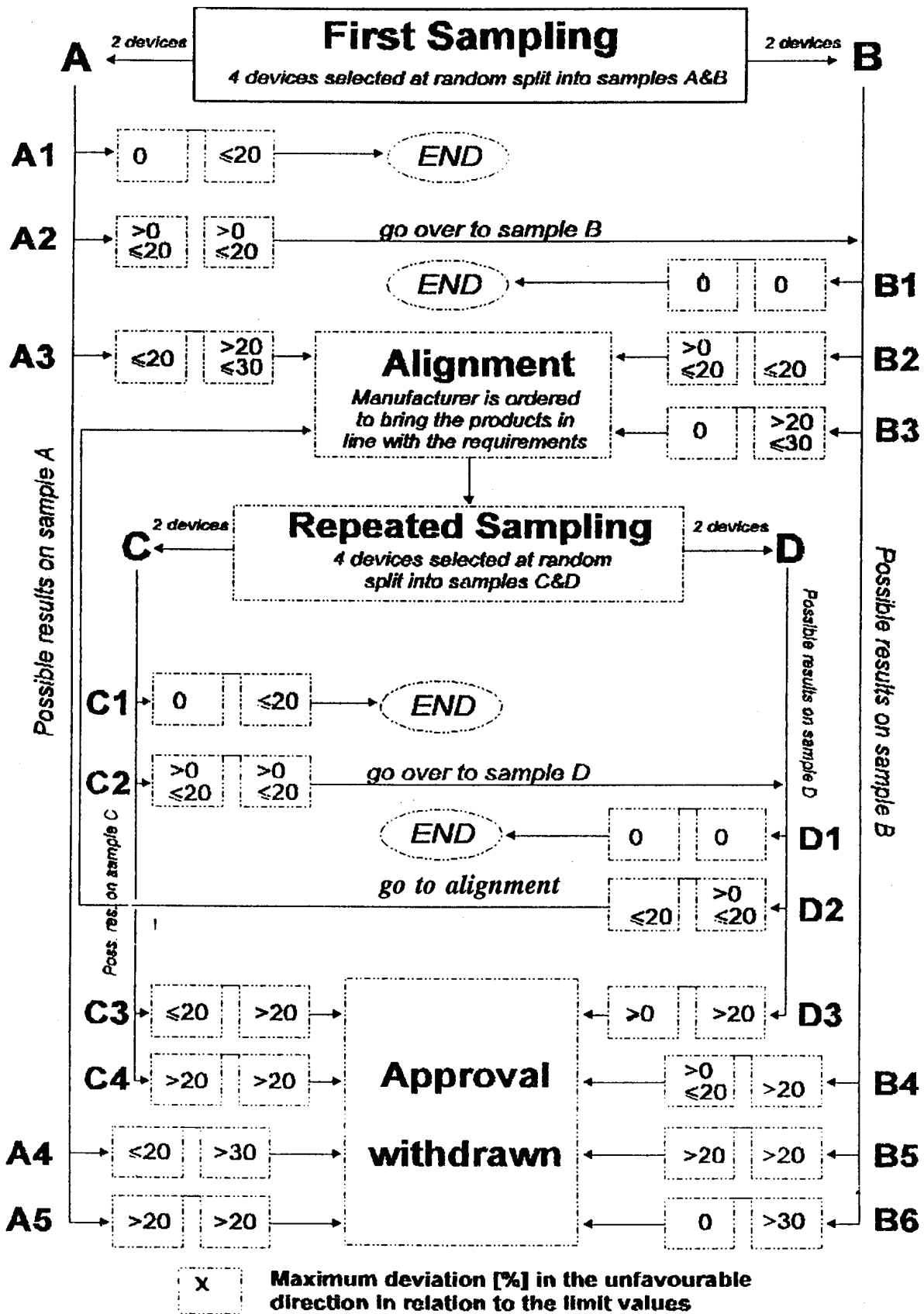

Figure 1

## **Regulation No. 2**

### **UNIFORM PROVISIONS CONCERNING THE APPROVAL OF INCANDESCENT ELECTRIC LAMPS FOR HEADLAMPS EMITTING AN ASYMMETRICAL PASSING BEAM OR A DRIVING BEAM OR BOTH**

#### **1. TRANSITIONAL PROVISIONS**

- 1.1. No new type approval shall be granted under this Regulation after the date of entry into force of the 03 Series of Amendments <sup>1/</sup> (March 9, 1986).
- 1.2. Type approvals granted before March 9, 1986 shall remain valid.
- 1.3. However, the Contracting Parties applying this Regulation may, from the date of entry into force of the 03 Series of Amendments, prohibit the fitting of category R2 filament lamps approved under this Regulation if they do not meet the requirements of Regulation No. 37.

---

<sup>1/</sup> The provisions applicable to the approval of incandescent filament lamps for headlamps emitting an asymmetrical passing beam or a driving beam or both are incorporated in Regulation No. 37.

## **APPENDIX B**

UN REGULATION No. 5/02

UNIFORM PROVISIONS CONCERNING THE APPROVAL OF POWER-DRIVEN  
VEHICLE'S SEALED BEAM HEADLAMPS (SB) EMITTING A EUROPEAN  
ASYMMETRICAL PASSING BEAM OR A DRIVING BEAM OR BOTH

## Regulation No. 5

### UNIFORM PROVISIONS FOR THE APPROVAL OF MOTOR VEHICLE "SEALED BEAM" HEADLAMPS (SB) EMITTING A EUROPEAN ASYMMETRICAL PASSING BEAM OR A DRIVING BEAM OR BOTH

#### CONTENTS

##### REGULATION

1. Scope
2. Definitions
3. Application for approval
4. Markings
5. Approval
6. General specifications
7. Rated values
8. Illumination
9. Colour
10. Remark concerning colour
11. Gauging of discomfort
12. Conformity of production
13. Penalties for non-conformity of production
14. Modifications of the type of sealed beam headlamp unit (SB unit) and extension of approval
15. Production definitely discontinued
16. Transitional provisions
17. Names and addresses of technical services responsible for conducting approval tests and of administrative departments

##### Annexes

- Annex 1 SB units for agricultural or forest tractors and other slow-moving vehicles
  - Annex 2 Communication concerning the approval or extension or withdrawal of approval or production definitely discontinued of a sealed beam headlamp unit (SB unit), pursuant to Regulation No. 5
  - Annex 3 Minimum requirements for conformity of production control procedures
  - Annex 4 Examples of arrangements of approval marks
  - Annex 5 Tests for stability of photometric performance of headlamps in operation.
  - Annex 6 Requirements for lamps incorporating lenses of plastic material - testing of lens or material samples and of complete lamp
- Appendix 1 Chronological order of approval tests

Appendix 2 Method of measurement of the diffusion and transmission of light

Appendix 3 Spray testing method

Appendix 4 Adhesive tape adherence test

Annex 7 Minimum requirements for sampling by an inspector

## 1. SCOPE <sup>1/</sup>

This Regulation applies to motor vehicle headlamps which may incorporate lenses of glass or plastic material.

## 2. DEFINITIONS

For the purpose of this Regulation,

- 2.1. "Sealed beam" headlamp unit (hereinafter termed "SB unit"), means a headlamp unit whose components, comprising a reflector system, a lens system and one or more electrical light sources are all parts of an integral whole which has been sealed in the course of manufacture and which cannot be dismantled without rendering the unit completely unusable;
- 2.2. "Lens" means the outermost component of the headlamp (unit) which transmits light through the illuminating surface;
- 2.3. "Coating" means any product or products applied in one or more layers to the outer face of a lens;
- 2.4. SB units are considered to be of different types if they differ in one or more of the following essentials of form or characteristics:
  - 2.4.1. Trade name or mark;
  - 2.4.2. Characteristics of the optical system;
  - 2.4.3. Inclusion of additional components capable of altering the optical effects by reflection, refraction, absorption and/or deformation during operation;
  - 2.4.4. The rated voltage (the same approval number may be granted if the only change is of rated voltage);
  - 2.4.5. The rated wattage;
  - 2.4.6. The shape of the filaments);
  - 2.4.7. The kind the beam produced (passing beam, driving beam or both);
  - 2.4.8. Suitability for right-hand or left-hand traffic or for both traffic systems;
  - 2.4.9. The colour of the light emitted;
  - 2.4.10. The materials constituting the lens and coating, if any.

## 3. APPLICATION FOR APPROVAL

- 3.1. The application for approval shall be submitted by the owner of the trade name or mark or by his duly accredited representative. It shall specify:
  - 3.1.1. Whether the SB unit is intended to provide both a passing beam and a driving beam, or only one of these beams;
  - 3.1.2. Whether, if the headlamp is intended to provide a passing beam, it is designed for both left-hand and right-hand traffic or for either left-hand or right-hand traffic only;

---

<sup>1/</sup> Nothing in this regulation shall prevent a Party to the Agreement applying this Regulation from prohibiting the combination of a headlamp incorporating a lens of plastic material approved under this Regulation with a mechanical headlamp-cleaning device (with wipers).

- 3.1.3. Where applicable, that it is designed for agricultural or forest tractors and other slow-moving vehicles (see annex 1).
- 3.2. Every application for approval shall be accompanied by:
  - 3.2.1. Drawings in triplicate, sufficiently detailed to permit identification of the type and giving a front view of the unit (with, if applicable, details of the lens moulding) and a cross-section; also the filament(s) and shield(s) shall be shown on the drawings at a scale of 2 : 1 both in front view and in side view; the drawing must show the position intended for the approval number and the additional symbols in relation to the circle of the approval mark;
  - 3.2.2. Brief technical description;
  - 3.2.3. Samples as follows:
    - 3.2.3.1. For approval of an SB unit to emit white light: five samples;
    - 3.2.3.2. For approval of a unit to emit coloured light: one coloured-light sample, and five white-light samples differing from the type submitted only in that the lens or filter is not coloured.
    - 3.2.3.3. In the case of SB units differing only in that they are designed to emit coloured light from a type designed to emit white light and which has previously satisfied the tests in paragraphs 6, 7 and 8 below, it will be sufficient to submit one sample of the coloured-light type to undergo only the tests given in paragraph 9.
  - 3.2.4. For the test of plastic material of which the lenses are made:
    - 3.2.4.1. thirteen lenses;
      - 3.2.4.1.1. six of these lenses may be replaced by six samples of material at least 60 x 80 mm in size, having a flat or convex outer surface and a substantially flat area (radius of curvature not less than 300 mm) in the middle measuring at least 15 x 15 mm;
      - 3.2.4.1.2. every such lens or sample of material shall be produced by the method to be used in mass production;
    - 3.2.4.2. a reflector to which the lenses can be fitted in accordance with the manufacturer's instructions.
- 3.3. The materials making up the lenses and coatings, if any, shall be accompanied by the test report of the characteristics of these materials and coatings if they have already been tested.
- 3.4. The competent authority shall verify the existence of satisfactory arrangements for ensuring effective control of the conformity of production before type approval is granted.
- 4. MARKINGS**<sup>2/</sup>
  - 4.1. SB units submitted for approval shall bear the trade name or mark of the applicant.

---

<sup>2/</sup> In the case of SB units designed to meet the requirements of traffic moving on one side of the road only (either right or left), it is further recommended that the area which can be occulted to prevent discomfort to users in a country where traffic moves on the side of the road opposite to that of the country for which the SB unit was designed should be outlined indelibly on the front lens. This marking is not necessary, however, where the area is clearly apparent from the design.

- 4.2. They shall comprise on the front lens, a space of sufficient size for the approval mark and the additional symbols provided for in paragraph 5 below; the space must be shown on the drawings referred to in paragraph 3.2.1. above.
- 4.3. They shall carry, either on the front lens or on the body, the values of the rated voltage and of the rated wattage of the driving beam filament, followed by that of the rated wattage of the passing beam filament, as applicable.
- 4.4. In the case of SB units designed to meet the requirements both of countries where the traffic keeps to the right and of those where the traffic keeps to the left, the two settings of the unit on the vehicle shall be marked by the letters "R/D" for the position for right-hand traffic and the letters "L/G" for the position for left-hand traffic.
- 4.5. The trade names or marks and markings provided for under this paragraph 4 shall be clearly legible and indelible.

## **5. APPROVAL**

### **5.1. General**

- 5.1.1. If all the headlamp type samples submitted in accordance with paragraph 3 above satisfy the provisions of this Regulation, approval shall be granted.
- 5.1.2. Where grouped, combined or reciprocally incorporated lamps satisfy the requirements of more than one Regulation, a single international approval mark may be affixed provided that each of the grouped, combined or reciprocally incorporated lamps satisfies the provisions applicable to it.
- 5.1.3. An approval number shall be assigned to each type approved. The same Contracting Party may not assign the same number to another type of headlamp covered by this Regulation except in the case of an extension of the approval to a device differing only in the colour of the light emitted.
- 5.1.4. Notice of approval or of extension or refusal or withdrawal of approval or production definitely discontinued, of a type of headlamp pursuant to this regulation shall be communicated to the Parties to the 1958 Agreement applying this Regulation, by means of a form conforming to the model in annex 2 to this Regulation.
- 5.1.5. In addition to the mark prescribed in paragraph 4.1, an approval mark as described in paragraphs 5.2 and 5.3 below shall be affixed in the spaces referred to in paragraph 4.2 above to every headlamp conforming to a type approved under this Regulation.

### **5.2. Composition of the approval mark**

The approval mark shall consist of:

- 5.2.1. An international approval mark, comprising:
  - 5.2.1.1. A circle surrounding the letter "E", followed by the distinguishing number of the country which has granted approval;<sup>3/</sup>

---

<sup>3/</sup> 1 for Germany, 2 for France, 3 for Italy, 4 for the Netherlands, 5 for Sweden, 6 for Belgium, 7 for Hungary, 8 for the Czech Republic, 9 for Spain, 10 for Yugoslavia, 11 for the United Kingdom, 12 for Austria, 13 for Luxembourg, 14 for Switzerland, 15 (vacant), 16 for Norway, 17 for Finland, 18 for Denmark, 19 for Romania, 20 for Poland, 21 for Portugal and 22 for the Russian Federation, 23 for Greece, 24(vacant), 25 for Croatia, 26

- 5.2.1.2. The approval number prescribed in paragraph 5.1.3 above.
- 5.2.2. The following additional symbol (or symbols):
- 5.2.2.1. On SB headlamps meeting left-hand traffic requirements only, a horizontal arrow pointing to the right of an observer facing the SB headlamp, i.e. to the side of the road on which the traffic moves;
- 5.2.2.2. On SB headlamps designed to meet the requirements of both traffic systems by means of an appropriate adjustment of the setting of the headlamp, a horizontal arrow with a head on each end, the heads pointing respectively to the left and to the right;
- 5.2.2.3. on headlamps meeting the requirements of this Regulation in respect of the passing beam only, the letters "SC";
- 5.2.2.4. on headlamps meeting the requirements of this Regulation in respect of the driving beam only, the letters "SR";
- 5.2.2.5. On headlamps meeting the requirements of this Regulation in respect of both the passing beam and the driving beam, the letters " SCR";
- 5.2.2.6. On headlamps incorporating a lens of plastic material, the group of letters "PL" shall be affixed near the symbols prescribed in paragraphs 5.2.2.3 to 5.2.2.5 above;
- 5.2.2.7. In every case the relevant operating mode during the next procedure according to paragraph of annex 5 and the allowed voltage(s) according to paragraph 1.1.1.2 of annex 5 shall be stipulated on the approval certificates and on the communication form transmitted to the countries which are Contracting Parties to the Agreement and which apply this Regulation.
- In the corresponding cases the device shall be marked as follows:
- On units meeting the requirements of this Regulation which are so designed that the filament of the passing beam shall not be lit simultaneously with that of any other lighting function with which it may be reciprocally incorporated:
- An oblique stroke (/) shall be placed behind the passing lamp symbol in the approval mark;
- 5.2.2.8. The two digits of the approval number (at present 02) which indicate the series of amendments incorporating the most recent major technical amendments-made to the Regulation and at the time of issue of the approval and, if necessary, the required arrow may be marked close to the above additional symbols;
- 5.2.2.9. The marks and symbols referred to in paragraphs 5.2.1 and 5.2.2 above shall be clearly legible and indelible even when the headlamp is fitted in the vehicle.
- 5.3. Arrangement of the approval mark

---

for Slovenia, 27 Slovakia, 28 for Belarus, 29 for Estonia, 30 (vacant), 31 for Bosnia and Herzegovina, 32-36 (vacant), 37 for Turkey, 38-39 (vacant) and 40 for The former Yugoslav Republic of Macedonia. Subsequent numbers will be assigned to other countries in the chronological order in which they ratify or accede to the Agreement concerning the Adoption of Uniform Technical Prescriptions for Wheeled Vehicles, Equipment and Parts which can be Fitted and/or be Used on Wheeled Vehicles and the Conditions for Reciprocal Recognition of Wheeled Vehicles and the Conditions for Reciprocal Recognition of Approvals granted on the basis of these Prescriptions, and the numbers thus assigned shall be communicated to the Contracting Parties to the Agreement by the Secretary- General of the United Nations.

### 5.3.1. Independent lamps

Annex 4, figures 1 to 9, to this Regulation gives examples of arrangements of the approval mark with the above-mentioned additional symbols.

### 5.3.2. Grouped, combined or reciprocally incorporated lamps

5.3.2.1. Where grouped, combined or reciprocally incorporated lamps have been found to comply with the requirements of several Regulations, a single international approval mark may be affixed, consisting of a circle surrounding the letter "E1" followed by the distinguishing number of the country which has granted the approval, and an approval number. This approval mark may be located anywhere on the grouped, combined or reciprocally incorporated lamps, provided that:

5.3.2.1.1. it is visible after their installation;

5.3.2.1.2. No part of the grouped, combined or reciprocally incorporated lamps that transmits light can be removed without at the same time removing the approval mark.

5.3.2.2. The identification symbol for each lamp appropriate to each Regulation under which approval has been granted, together with the corresponding series of amendments incorporating the most recent major technical amendments to the Regulation at the time of issue of the approval and, if necessary, the required arrow shall be marked:

5.3.2.2.1. Either on the appropriate light-emitting surface,

5.3.2.2.2. Or in a group, in such a way that each of the grouped, combined or reciprocally incorporated lamps may be clearly identified (see four possible examples in annex 4).

5.3.2.3. The size of the components of a single approval mark shall not be less than the minimum size required for the smallest of the individual marks by the Regulation under which approval has been granted.

5.3.2.4. An approval number shall be assigned to each type approved. The same Contracting Party may not assign the same number to another type of grouped, combined or reciprocally incorporated lamps covered by this Regulation.

5.3.2.5. Annex 4, figure 10, to this Regulation gives examples of arrangements of approval marks for grouped, combined or reciprocally incorporated lamps with all the above-mentioned additional symbols.

5.3.3. Lamps, the lens of which is used for different types of headlamps and which may be reciprocally incorporated or grouped with other lamps

The provisions laid down in paragraph 5.3.2 above are applicable.

5.3.3.1. In addition, where the same lens is used, the latter may bear the different approval marks relating to the different types of headlamps or units of lamps, provided that the main body of the headlamp, even if it cannot be separated from the lens, also comprises the space described, in paragraph 4.2 above and bears the approval mark of the actual functions.

If different types of headlamps comprise the same main body, the latter may bear the different approval marks.

- 5.3.3.2. Annex 4, figure 11, to this Regulation gives examples of arrangements of approval marks relating to the above case.

## **6. GENERAL SPECIFICATIONS**

- 6.1. Each sample shall conform to the specifications set forth in this paragraph 6 and in paragraphs 7 and 8 below, and, if necessary, paragraph 9.
- 6.2. SB units shall be so made as to, retain their prescribed photometric characteristics and to remain in good working order when in normal use, despite the vibrations to which they may be subjected.
- 6.2.1. Headlamps shall be fitted with a device enabling them to be so adjusted on the vehicle as to comply with the rules applicable to them. Such a device need not be fitted on the SB headlamp inserts if the use of such inserts is confined to vehicles on which the headlamp setting can be adjusted by other means. Where an SB headlamp providing a driving beam and an SB headlamp providing a passing beam are assembled as exchangeable subunits to form a composite unit the adjusting device shall enable each SB unit individually to be duly adjusted.
- 6.2.2. However, this will not apply to headlamp assemblies whose reflectors are indivisible. For this type of assembly the requirements of paragraph 8 of this Regulation shall apply. In the case where more than one light source is used to provide the main beam the combined main-beam functions will be used to determine the maximum value of the illumination ( $E_{max}$ ).
- 6.3. The terminals shall only be in electrical connection with the appropriate filament or filaments and shall be robust and firmly fixed to the unit.
- 6.4. If the units are circular they shall provide all the physical features and electrical connections shown in one of the plates SB2 - SB7 in annex 4 and shall be made to the dimensions in that plate.
- 6.5. SB units designed to meet the requirements both of countries where the traffic keeps to the right and of those where the traffic keeps to the left, may be adapted for traffic on a given side of the road either by an appropriate initial setting when fitted on the vehicle, or by selective setting by the user. Such initial or selective setting may consist, for example, of fixing the angular setting of the unit on the vehicle. In all cases, only two precise setting positions, one for right-hand and one for left-hand traffic, shall be possible, and the design shall preclude inadvertent shifting of the unit from the one position to the other or its setting in an intermediate position. Conformity with the requirements of, this paragraph shall be verified visually and, where necessary, by a test fitting.
- 6.6. Complementary tests shall be done according to the requirements of annex 5 to ensure that in use there is no excessive change in photometric performance.
- 6.7. If the lens of the headlamp is of plastic material, tests shall be done according to the requirements of annex 6.

## **7. RATED VALUES**

- 7.1. The values of rated voltage are: 6, 12 and 24 volts<sup>4/</sup>.
- 7.2. The power consumed at the test voltage by any submitted SB unit shall not exceed the rated wattage marked on the unit, by more than the percentage specified in

---

<sup>4/</sup> 24-volt units are under consideration.

table 1. No lower limit is specified for the tolerance on wattage but the minimum illumination values specified in table 2 of paragraph 8.8 must be obtained.

**Table 1**

		Circular units of 180 mm diameter		Circular units of 145 mm diameter	
Rated voltage		6	12	6	12
Test voltage		6	12	6	12
		Rated wattage and permitted tolerance			
Double filaments <sup>5/</sup>	Driving beam	60 + 0%		37.5 + 0%	
	Passing beam	50 + 0%		50 + 0%	
	Driving beam filament only	75 + 0%		50 + 0%	
	Passing beam filament only	50 + 0%		50 + 0%	

**8. ILLUMINATION** <sup>6/</sup>

- 8.1. SB units shall be so made as to give adequate illumination without dazzle for the passing beam, and good illumination for the driving beam.
- 8.2. The illumination produced by the unit shall be checked on a vertical screen set at a distance of 25 m in front of the unit and .at right angles to its axis (see annex 4, plates SB<sub>8a</sub> and SB<sub>8b</sub>).
- 8.3. The passing beam must produce a sufficiently sharp "cut-off" to permit satisfactory alignment with its aid. The "cut-off" must be a horizontal line on the side opposite to the direction of the traffic for which the unit is intended; on the other side it should be horizontal or within an angle of 15 degrees above the horizontal.
- 8.4. The SB unit shall be aimed so that on passing beam:
  - 8.4.1. In the case of units designed to meet the requirements of right-hand traffic, the "cut-off" on the left half of the screen <sup>7/</sup> is horizontal and, in the case of units designed to meet the requirements of left-hand traffic, the "cut-off" on the right half of the screen is horizontal;
  - 8.4.2. This horizontal part of the "cut-off" is situated, on the screen, 25 cm below the level of the horizontal plane passing through the focus of the unit (see annex 4, plates SB<sub>8a</sub> and SB<sub>8b</sub>);
  - 8.4.3. The screen is in the position indicated in annex 4, plates SB<sub>8a</sub> and SB<sub>8b</sub>.<sup>8/</sup>
- 8.5. When so aimed, the unit need, if its approval is sought solely for a passing beam,<sup>9/</sup> meet only the requirements referred to in paragraph 8.8 below; if it is intended to

<sup>5/</sup> In the case of SB units with double filaments, the samples may be submitted for approval for the two functions or for the passing beam only.

<sup>6/</sup> All the photometric measurements shall be carried out at the test voltage given in paragraph 7.

<sup>7/</sup> The test screen must be sufficiently wide to allow examination of the "cut-off" over a range of at least 5 degrees from the line vv.

<sup>8/</sup> If, in the case of a unit designed to meet the requirements of this Regulation with respect to the passing beam only, the focal axis diverges appreciably in from the general direction of the beam, lateral adjustment shall be effected in the manner which best satisfies the requirements for illumination at points 75 R and 50 R for right-hand traffic and at points 75 L and 50 L for left-hand traffic.

provide both a passing beam and a driving beam it shall meet the requirements referred to in paragraphs 8.8 and 8.9.

- 8.6. Where an SB unit so aimed does not meet the requirements referred to in paragraphs 8.8 and 8.9 below, its alignment may be changed, provided that the axis of the beam is not laterally displaced by more than 1 degrees (= 44 cm) to the right or left. 10/ To facilitate alignment by means of the "cut-off", the unit may be partially occulted in order to sharpen the "cut-off".
- 8.7. In the case of an SB unit providing a driving beam only, it shall be so aimed that the area of maximum illumination is centred on the point of intersection HV of the lines hh and vv; such a unit need meet only the requirements referred to in paragraph 8.9.
- 8.8. The illumination produced on the screen by the passing beam shall meet the following requirements:

**Table 2**

Point on measuring screen		Required illumination in lux	
SB units for right-hand traffic	SB units for left-hand traffic	Minimum	Maximum
B 50 L	B 50 R	-	0.3
75 R	75 L	6	-
50 R	50 L	6	-
25 L	25 R	1.5	-
25 R	25 L	1.5	-
Every point in Zone III		-	0.7
" " " "	IV	2	-
" " " "	I	-	20

- 8.8.1. There shall be no lateral variations detrimental to good visibility in any of the zones, I, II, III and IV;
- 8.8.2. SB units designed to meet the requirements of both right-hand and left-hand traffic must, in each of the two setting positions, meet the requirements set forth above for the corresponding direction of traffic.
- 8.9. In the case of an SB unit designed to provide a driving beam and a passing beam, measurements of the illumination produced on the screen by the driving beam shall be taken with the same unit alignment and voltage as for measurements under paragraph 8.8 above.
- 8.10. The illumination produced on the screen by the driving beam shall meet the following requirements:
- 8.10.1. The point of intersection HV of the line hh and vv shall be situated within the isolux 90% of maximum illumination. The maximum value shall not be less than 32 lux;
- 8.10.2. Starting from point HV, horizontally to the right and left, illumination shall be not less than 16 lux up to a distance of 1.125 metres, and not less than 4 lux up to a distance of 2.25 metres.

<sup>9/</sup> A unit designed to emit a passing beam may incorporate a driving beam not complying with the specification.  
<sup>10/</sup>The limit of realignment of 1 degrees towards the right or left is not incompatible with vertical realignment,, which is only limited by the conditions laid down in paragraph 8.9.

- 8.11. The screen illumination values mentioned in paragraphs 8.8 and 8.9 above shall be measured by means of a photoelectric cell, the effective area of which shall be contained within a square of 65 mm side.

## 9. COLOUR

The light emitted shall be white or selective yellow. In the latter case the dominant wavelength must be between 5,750 and 5,850 Angstrom units, the purity factor shall be between 0.90 and 0.98 and the illumination produced on the screen by the passing beam must meet the requirements of Table 2 with all the figures multiplied by a factor of 0.84.<sup>11/</sup>

## 10. REMARK CONCERNING COLOUR

Any approval under this Regulation which is granted by virtue of paragraph 9 above for a type of SB unit emitting white light or selective yellow light, does not prevent the Contracting Parties from prohibiting, on the vehicles which they register, SB units emitting-either white or selective yellow light, according to article 3 of the Agreement to which this Regulation is attached.

## 11. GAUGING OF DISCOMFORT

The discomfort caused by the passing beam of SB units shall be gauged.<sup>12/</sup>

## 12. CONFORMITY OF PRODUCTION

- 12.1. Headlamps approved under this Regulation shall be so manufactured as to conform to the type approved by the meeting the requirements set forth in paragraphs 8 and 9.
- 12.2. In order to verify that the requirements of paragraph 12.1. are met, suitable controls of the production shall be carried out.
- 12.3. The holder of the approval shall in particular:
- 12.3.1. ensure the existence of procedures for the effective control of the quality of products;
- 12.3.2. have access to the control equipment necessary for checking the conformity to each approved type;
- 12.3.3. ensure that data of test results are recorded and that related documents shall remain available for a period to be determined in accordance with the administrative service;
- 12.3.4. analyze the results of each type of test in order to verify and ensure the stability of the product characteristics, making allowance for variation of an industrial production;
- 12.3.5. ensure that for each type of product at least the tests prescribed in annex 3 to this Regulation are carried out ;

---

<sup>11/</sup> These specifications correspond to the following trichromatic coordinates: selective yellow (yellow within the meaning of annex 5, appendix, of the 1968 Convention on Road Traffic)

Limit towards red  $y > 0.138 + 0.580x$

Limit towards green  $y < 1.29x - 0.100$

Limit towards white  $y > -x + 0.966$

Limit towards spectrum edge  $y < -x + 0.992$

<sup>12/</sup> This requirement will be the subject of a recommendation for the benefit of administrations.

- 12.3.6. ensure that any collecting of samples of giving evidence of nonconformity with the type of test considered shall give rise to another sampling and another test. All the necessary steps shall be taken to re-establish the conformity of the corresponding production.
- 12.4. The competent authority which has granted type approval may at any time verify the conformity control methods applicable to each production unit.
- 12.4.1. In every inspection, the test books and production survey records shall be presented to the visiting inspector.
- 12.4.2. The inspector may take samples at random to be tested in the manufacture's laboratory. The minimum number of samples may be determined in the light of the results of the manufacturer's own checks.
- 12.4.3. When the quality level appears unsatisfactory or when it seems necessary to verify the validity of the test carried out in the application of paragraph 12.4.2. above, the inspector shall select samples, to be sent to the technical service which has conducted the type approval tests, using the criteria of annex 7.
- 12.4.4. The competent authority may carry out any test prescribed in this Regulation. These tests will be on samples selected at random without causing distortion of the manufacturer's delivery commitments and in accordance with the criteria of annex 7.
- 12.4.5. The competent authority shall strive to obtain a frequency of inspection of once every two years, However, this is at the discretion of the competent authority and their confidence in the arrangements for ensuring effective control of the conformity of production. In the case where negative results are recorded, the competent authority shall ensure that all necessary steps are taken to re-establish the conformity of production as rapidly as possible.
- 12.5. Headlamps with apparent defects are disregarded.
- 12.6. The reference mark is disregarded.

### **13. PENALTIES FOR NON-CONFORMITY OF PRODUCTION**

- 13.1. The approval granted in respect of an SB unit pursuant to this Regulation may be withdrawn if the requirements set forth above are not met, or if a unit, bearing the approval mark does not conform to the type approved.
- 13.2. If a Contracting Party to the Agreement applying this Regulation withdraws an approval it has previously granted, it shall forthwith so notify the other Contracting Parties applying this Regulation, by means of a communication form conforming to the model in annex 2 to this Regulation.

#### **14. MODIFICATIONS OF THE TYPE OF SEALED BEAM HEADLAMP UNIT (SB UNIT) AND EXTENSION OF APPROVAL**

- 14.1 Every modification of the type of sealed beam headlamp unit (SB unit) shall be notified to the administrative department which approved the type of sealed beam headlamp unit (SB unit). The department may then either:
- 14.1.1. Consider that the modifications made are unlikely to have an appreciable adverse effect and that in any case the sealed beam headlamp unit (SB unit) still complies with the requirements; or
- 14.1.2. Require a further test report from the technical service responsible for conducting the tests.
- 14.2. confirmation or refusal of approval, specifying the alterations, shall be communicated by the procedure specified in paragraph 5.1.4. above to the Parties to the Agreement applying this Regulation.
- 14.3. The competent authority issuing the extension of approval shall assign a series number to each communication form drawn up for such an extension and inform thereof the other parties to the 1958 Agreement applying this Regulation by means of a communication form conforming to the model in annex 2 to this Regulation.

#### **15. PRODUCTION DEFINITELY DISCONTINUED**

If the holder of tile approval completely ceases to manufacture a device approved in accordance with this Regulation he shall so inform the authority which granted the approval. Upon receiving the relevant communication that authority shall inform thereof the other Parties to the 1958 Agreement applying this Regulation by means of a communication form conforming to the model in annex 2 to this Regulation.

#### **16. TRANSITIONAL PROVISIONS**

- 16.1 As from the date of entry into force of the 02 series of amendments to this Regulation no Contracting Party applying it shall refuse to grant approvals under this Regulation as amended by the 02 series of amendments.
- 16.2. As from 24 months after the date of entry into force mentioned in paragraph 16.1 above, Contracting Parties applying this Regulation shall grant approvals only if the type of headlamp corresponds to the requirements of this Regulation as amended by the 02 series of amendments.
- 16.3. Existing approvals granted under this Regulation before the date mentioned in paragraph 16.2 above shall remain valid.
- However, Contracting Parties applying this Regulation may prohibit the fitting of devices which do not meet the requirements of this Regulation as amended by the 02 series of amendments:
- 16.3.1. On vehicles for which type approval or individual approval is granted more than 24 months after the date of entry into force mentioned in paragraph 16.1 above;
- 16.3.2. On vehicles first registered more than five years after the date of entry into force mentioned in paragraph 16.1 above.

**17. NAMES AND ADDRESSED OF TECHNICAL SERVICES RESPONSIBLE FOR CONDUCTING APPROVAL TESTS AND OF ADMINISTRATIVE DEPARTMENTS**

The Parties to the 1958 Agreement applying this Regulation shall communicate to the United Nations Secretariat the names and addresses of the technical services responsible for conducting approval tests and of the administrative departments which grant approval and to which forms certifying approval or refusal or, extension or withdrawal of approval, or production definitely discontinued, issued in other countries, are to be sent.

## Annex 1

### SB UNITS FOR AGRICULTURAL OR FOREST TRACTORS AND OTHER SLOW-MOVING VEHICLES

1. The provisions of this Regulation shall also apply to the approval of special SE units for agricultural or forest tractors and other slow-moving vehicles, such units being intended to provide both a driving beam and a passing beam and having a diameter<sup>\*/</sup> of less than 160 mm with the following modifications:
  - 1.1. The minimum requirements for illumination laid down in paragraph 8.8. of this Regulation shall be reduced in the ratio
$$\frac{(D - 45)^2}{(160 - 45)}$$
subject to the following absolute lower limits:
    - 3 lux at either point 75R or point 75L;
    - 5 lux at either point 50R or point 50L;
    - 1.5 lux in zone IV;
  - 1.2. Instead of the symbols provided for in paragraph 5.2.2. of this Regulation, the unit shall be marked with the letters "SM" in an inverted triangle.

---

<sup>\*/</sup> If the projected area of the reflector is not circular, the diameter shall be that of a circle having the same area as the projected area of the apparent useful surface of the reflector.

**Annex 2**

**(maximum format: A4 (210 x 297 mm))**

**COMMUNICATION**

issued by: Name of administration:

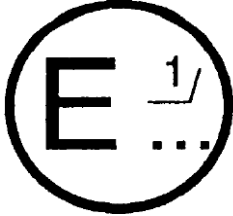

concerning: <sup>2/</sup>

- APPROVAL GRANTED
- APPROVAL EXTENDED
- APPROVAL REFUSED
- APPROVAL WITHDRAWN
- PRODUCTION DEFINITELY DISCONTINUED

of a type of sealed beam headlamp unit (SB unit) pursuant to Regulation No. 5

Approval No.

Extension No.

1. SB unit submitted for approval as type <sup>3/</sup>  
Colour of light emitted: white/selective yellow <sup>2/</sup>  
Rated voltage  
Rated wattage
2. The passing lamp filament may/may not <sup>2/</sup> be lit simultaneously with the driving lamp filament and/ or another reciprocally incorporated lamp
3. Trade name or mark
4. Manufacturer's name and address
5. If applicable, name and address of manufacturer's representative
6. Submitted for approval on
7. Technical service responsible for conducting approval tests
8. Date of report issued by that service
9. Number of report issued by that service
10. Approval granted/refused/extended/withdrawn <sup>2/</sup>  
(See foot-notes at the end of this Annex)
11. Reason(s) of extension (if applicable)

<sup>1/</sup> Distinguishing number of the country which has granted/extended/ refused/withdrawn approval (see approval provisions in the Regulation).

<sup>2/</sup> Strike out what does not apply.

<sup>3/</sup> Indicate the appropriate marking selected from the list below:

SCR, SCR, SCR, SC, SC, SC, SR, SM, SM, SM, SC/R, SC/R, SC/R,  
→ ↔ → ↔ → ↔ → ↔ → ↔

SC/, SC/, SC/, SCR PL, SCR PL, SCR PL, SC PL, SC PL, SC PL  
→ ↔ → ↔ → ↔ → ↔ → ↔

SR PL, SMPL, SMPL, SMPL, SC/R PL, SC/R PL, SC/R PL, SC/PL, SC/PL, SC/PL  
→ ↔ → ↔ → ↔ → ↔ → ↔

12. Maximum intensity (in lux) of the driving beam at 25 m from the unit
13. Extension of approval to headlamps emitting white/selective-yellow light <sup>2/</sup>
  - 13.1. Test laboratory
  - 13.2. Date and number of laboratory report
  - 13.3. Date of extension of the approval
14. Place
15. Date
16. Signature
17. The attached drawing, No.        shows the unit in front view (with, if applicable, details of the lens moulding) and a cross-section.

### Annex 3

## MINIMUM REQUIREMENTS FOR CONFORMITY OF PRODUCTION CONTROL PROCEDURES

### 1. GENERAL

- 1.1. The conformity requirements shall be considered satisfied from a mechanical and geometric standpoint, if the differences do not exceed inevitable manufacturing deviations within the requirements of this Regulation.
- 1.2. With respect to photometric performances, the conformity of mass-produced headlamps shall not be contested if, when testing photometric performances of any headlamp chosen at random:
- 1.2.1. no measured value deviates unfavorably by more than 20% from the values prescribed in this Regulation. For value B 50 L (or R) and zone III, the maximum unfavorable deviation may be respectively:
- |                |      |                    |
|----------------|------|--------------------|
| B 50 L (or R): | 0.2  | 1x equivalent 20 % |
|                | 0.3  | 1x equivalent 30 % |
| Zone III:      | 0.3  | 1x equivalent 20 % |
|                | 0.45 | 1x equivalent 30 % |
- 1.2.2. or if
- 1.2.2.1. for the passing beam, the values prescribed in this Regulation are met at HV (with a tolerance of + 0.2 1x) and related to that aiming at least one point of each area delimited on the measuring screen (at 25 m) by a circle 15 cm in radius around points B 50 L (or R)<sup>1/</sup> (with a tolerance of + 0.1 1x), 75 R (or L), 25 R, 25 L, and in the entire area of zone IV which is not more than 22.5 cm above line 25 R and L;
- 1.2.2.2. and if, for the driving beam, HV being situated within the isolux 0.75 E max, a tolerance of + 20% for maximum values and -20% for minimum values is observed for the photometric value at any measuring point specified in paragraph 8.10. of this Regulation.
- 1.2.3. If the results of the tests described above do not meet the requirements, the alignment of the headlamp may be changed, provided that the axis of the beam is not displaced laterally by more than 1 degrees to the right or left.<sup>10/</sup>
- 1.3. With respect to the verification of the change in vertical position of the cut-off line under the influence of heat, the following procedure shall be applied:
- One of the sampled headlamps shall be tested according to the procedure described in paragraph 2.1, of annex 5 after being subjected three consecutive times to the cycle described in paragraph 2.2.2. of annex 5.
- The headlamps shall be considered as acceptable if  $\Delta r$  does not exceed 1.5 mrad.

<sup>1/</sup> Letters in brackets refer to headlamps intended for left-hand traffic.

<sup>10/</sup> See the corresponding footnotes in the text of the Regulation.

If this value exceeds 1.5 mrad but is not more than 2.0 mrad, a second headlamp shall be subjected to the test after which the mean of the absolute values recorded on both samples shall not exceed 1.5 mrad.

- 1.4. The chromaticity coordinates shall be complied with.

The photometric performance of a headlamp emitting selective yellow light shall be the values contained in this Regulation multiplied by 0.84.

## **2. MINIMUM REGULATION FOR VERIFICATION OF CONFORMITY BY THE MANUFACTURE**

For each type of headlamp the holder of the approval mark shall carry out at least the following tests, at appropriate intervals. The tests shall be carried out in accordance with the provisions of this Regulation.

If any sampling shows non-conformity with regarded to the type of test concerned, further samples shall be taken and tested. The manufacture shall taken steps to ensure the conformity of the production concerned.

### **2.1. Nature of tests**

Tests of conformity in this Regulation shall cover the photometric characteristics and the verification of the change in vertical position of the cut-off line under the influence of heat.

### **2.2. Method used in tests**

- 2.2.1. Tests shall generally be carried out in accordance with the methods set out in this Regulation.

- 2.2.2. In any tests of conformity carried out by the manufacturer, equivalent methods may be used with the consent of the competent authority responsible for approval test. The manufacturer is responsible for proving that the applied methods are equivalent to those laid down in this Regulation.

- 2.2.3. The application of the paragraphs 2.2.1. and 2.2.2. requires regular calibration of test apparatus and its correlation with measurements made by a competent authority.

- 2.2.4. In all cases the reference methods shall be those of this Regulation, particularly for the purpose of administrative verification and sampling.

### **2.3. Nature of sampling**

Samples of the headlamps shall be selected at random from the production of a uniform batch. A uniform batch means a set of headlamps of the same type, defined according to the production methods of the manufacture.

The assessment shall be general cover series production from individual factories. However, a manufacture may group together records concerning the same type from several factories, provided these operate under the same quality system and quality management.

2.4. Measured and recorded photometric characteristics

The sampled headlamp shall be subjected to photometric measurements at the points provided for in the Regulation, the reading being limited to points Emax, HV<sup>1/</sup>, HL, HR<sup>2/</sup>

in the case of the driving beam, and to points B 50 L (or R), HV, 75 R (or L) and 25 L (or R) on the case of the passing beam (see figure in annex 4).

2.5. Criteria governing acceptability

The manufacturer is responsible for carrying out a statistical study of the test results and for defining, in agreement with the competent authority, criteria governing the acceptability of his products in order to meet the specifications laid down for verification of conformity of products in paragraph 12.1 of this Regulation.

The criteria governing the acceptability shall be such that, with a confidence level of 95 %, the minimum probability of passing a spot check in accordance with annex 7 (first sampling) would be 0.95.

---

<sup>1/</sup> When the driving beam is reciprocally incorporated with the passing beam, HV in the case of the driving beam shall be the same measuring point as in the case of the passing beam.

<sup>2/</sup> HL and HR: points on "hh" located at 1.125 m to the left and to the right of point HV respectively.

Annex 4

EXAMPLES OF ARRANGEMENTS OF APPROVAL MARKS

1.

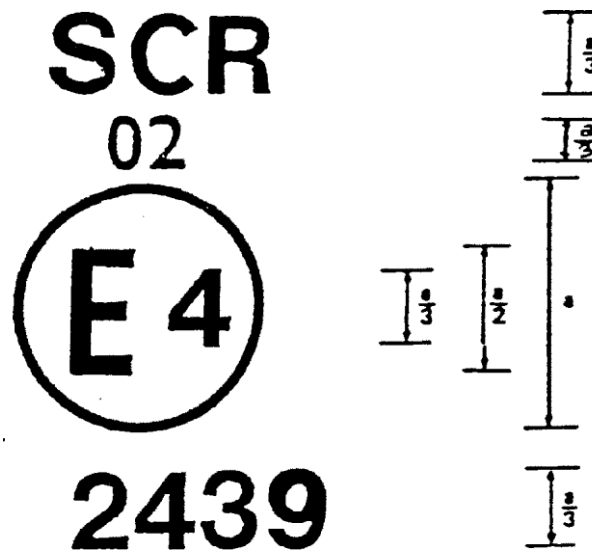

$a = 12 \text{ mm min.}$

**Figure 1**

The SB headlamp bearing the approval marking shown above is a headlamp approved in the Netherlands (E4), meeting the requirements of this Regulation as amended by the 02 series of amendments in respect of both the driving beam and the passing beam (SCR), and which is designed for right-hand traffic only.

NOTE: The approval number and the additional symbol(s) shall be placed close to the circle and either above or below the letter 'E', or to the right or left of that letter. The digits of the approval number shall be on the same side of the letter 'E' and face the same direction.

The additional symbol(s) must be diametrically opposed to the approval number.

The use of Roman numerals as approval numbers should be avoided so as to prevent any confusion with other symbols.

2.

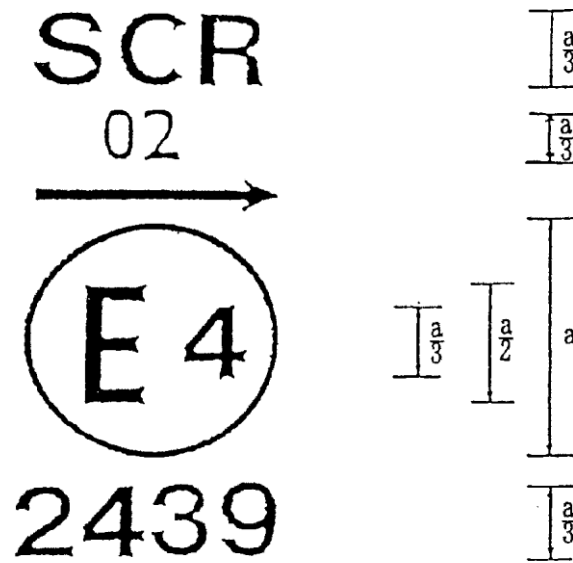

a = 12 mm min.

**Figure 2**

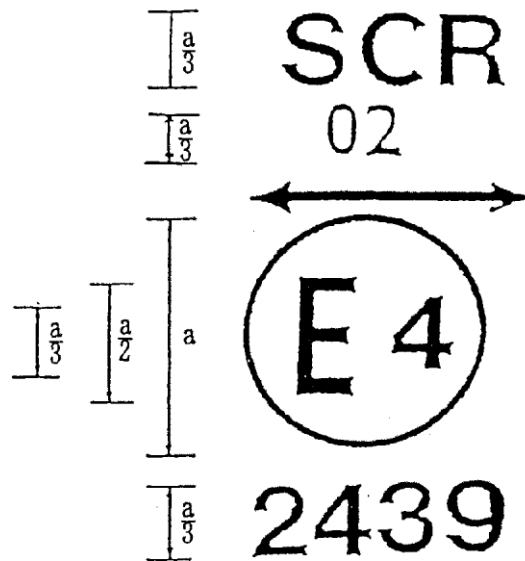

**Figure 3a**

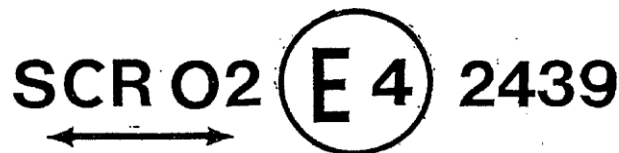

**Figure 3b**

The SB headlamp bearing the approval marking shown above is a headlamp meeting the requirements of this Regulation with respect to both the passing beam and the driving beam and designed:

Figure 2 = For left-hand traffic only.

Figure 3a, 3b = For both traffic systems, by means of an adjustment as desired of the headlamp.

3.

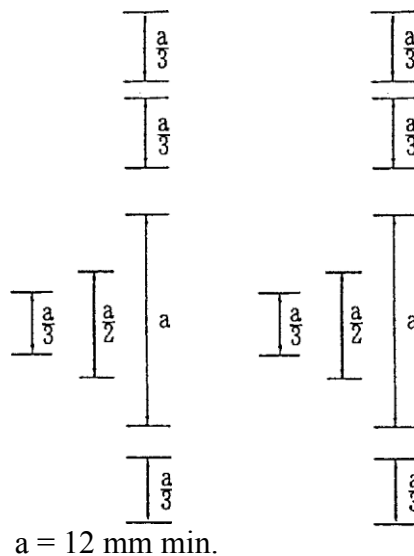
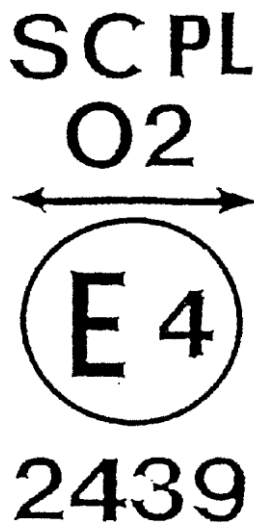

**Figure 4**

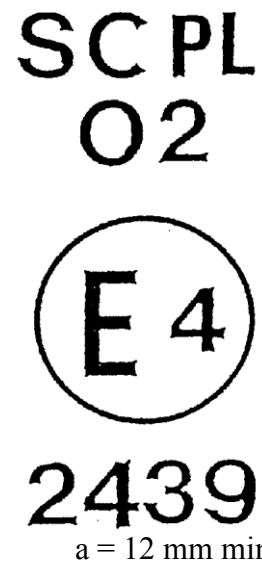

a = 12 mm min.

**Figure 5**

The SB headlamp bearing the approval mark shown above is a headlamp incorporating the lens of plastic, material meeting the requirements of this Regulation with respect to the passing beam only, and designed:

figure 4 = For both traffic systems.

figure 5 = For right-hand traffic only.

4.

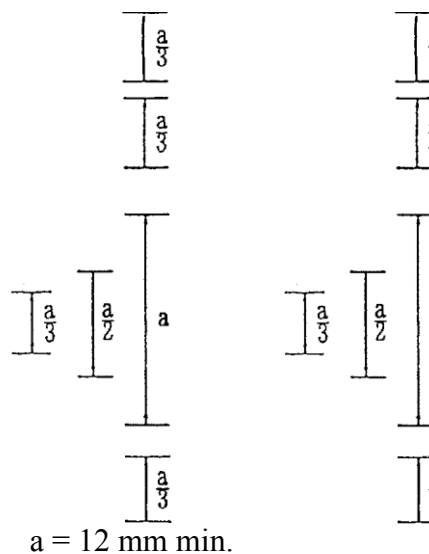
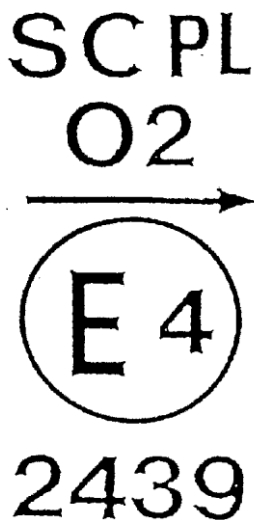

**Figure 6**

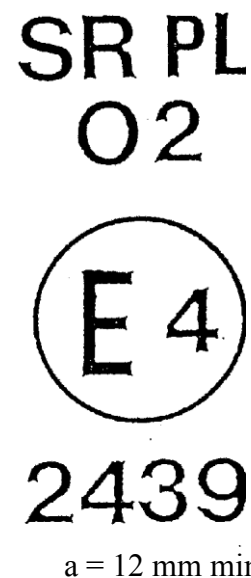

a = 12 mm min.

**Figure 7**

The SB headlamp bearing the approval mark shown above is a headlamp incorporating the lens of plastic material meeting the requirements of this Regulation:

Figure 6 = With respect to the passing beam only, and designed for left-hand traffic only.

Figure 7 = With respect to the driving beam only.

5.

SC/R  
O2

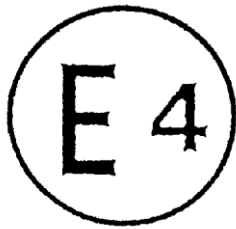

2439

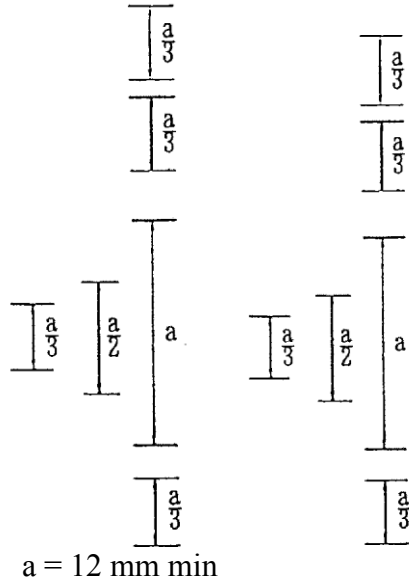

**Figure 8**

SC/

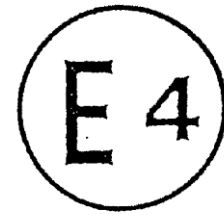

O2 2439

a = 12 mm min.

**Figure 9**

Identification of a headlamp meeting the requirements of Regulation No. 5

Figure 8 = with respect to both the passing beam and the driving beam and designed for right-hand traffic only.

Figure 9 = with respect to the passing beam only and designed for right-hand traffic only.

The passing lamp filament shall not be lit simultaneously with the driving lamp filament and/or another reciprocally incorporated lamp.

6. Examples of simplified markings for grouped, combined or reciprocally incorporated lamps (The vertical and horizontal lines schematize the shape of the light-signalling device. They are not part of the approval mark).

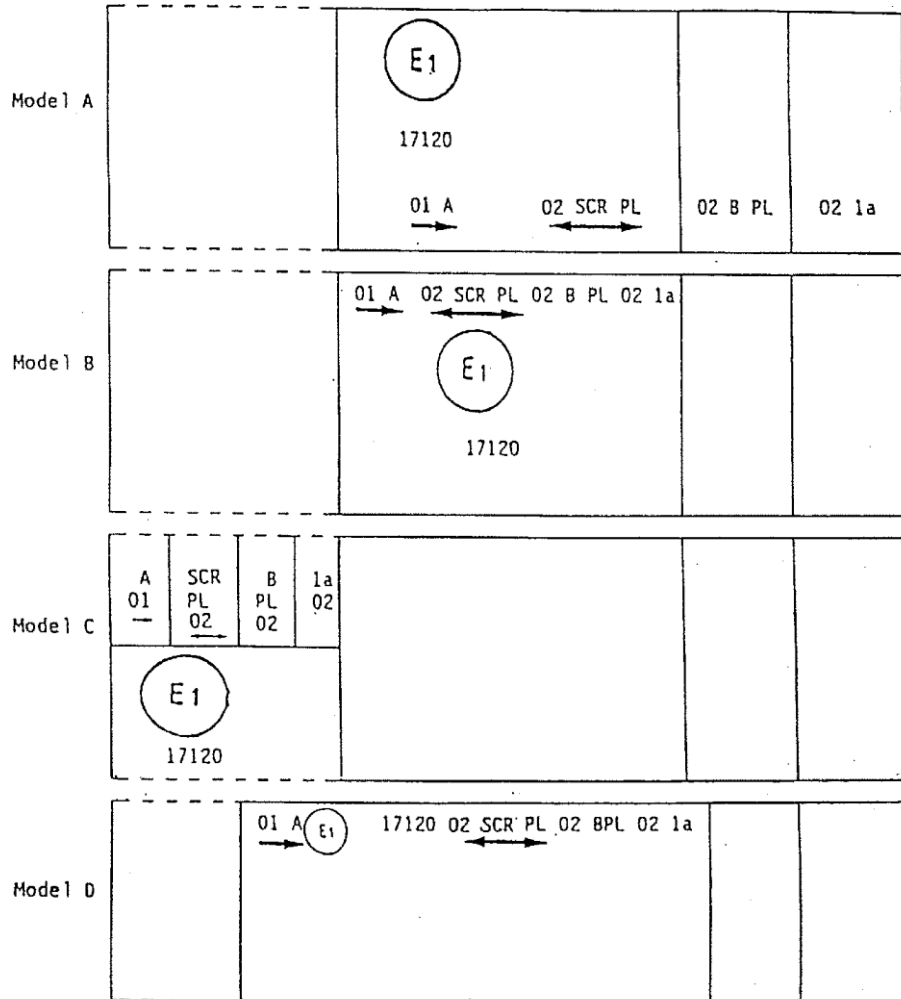

NOTE:

The four examples shown above correspond to a lighting device bearing an approval mark relating to:

A front Position lamp approved in accordance with the 01 series of amendments to Regulation No. 7;

A headlamp meeting the requirements of this Regulation with respect to the passing beam and to the driving beam, and designed for both traffic systems and incorporating a lens of plastic material;

A front fog lamp approved in accordance with the 02 series of amendments to Regulation No. 19 and incorporating a lens of plastic material;

A front direction indicator lamp of category 1 a approved in accordance with the 02 series of amendments to Regulation No. 6.

**Figure 11**  
**Lamp reciprocally incorporated with a headlamp**  
**Example 1**

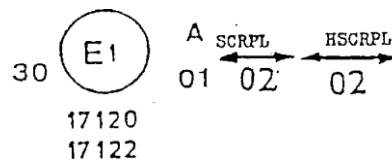

The above example corresponds to the marking of a lens of plastic material intended to be used in different types of headlamps, namely:

either: a headlamp with a passing beam designed for right-hand and left-hand traffic and

a driving beam approved in Germany (E1) in accordance with the requirements of Regulation No. 5 as amended by the 02 series of amendments, which is reciprocally incorporated with a front position lamp approved in accordance with the 01 series of amendments to Regulation No. 7;

or:

a headlamp with a passing beam designed for right-hand and left-hand traffic and a driving beam with a maximum intensity comprised between 86,250 and 101,250 candelas, approved in Germany (E1) in accordance with the requirements of Regulation No. 31 as amended by the 02 series of amendments which is reciprocally incorporated with the same front position lamp as above;

or even: either of the above-mentioned headlamps approved as a single lamp.

The main body of the headlamp shall bear the only valid approval number, for instance:

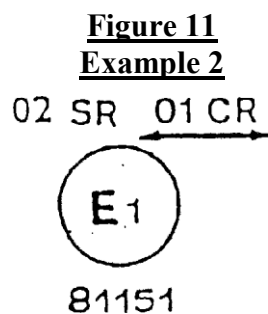
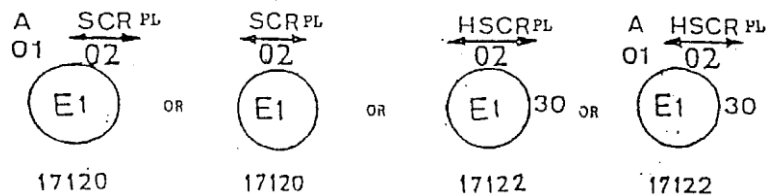

The above example corresponds to the marking of a lens used in an assembly of two headlamps approved in Germany (E1), consisting of a headlamp emitting a passing beam designed for both traffic systems and of a driving beam meeting the requirements of Regulation No. 1, and of a headlamp emitting a driving beam meeting the requirements of Regulation No. 5.

PLATE SB2 - SEALED BEAM HEADLAMP UNIT, 180mm (7in) DIA. TYPE 2 DOUBLE BEAM (PASSING & DRIVING)

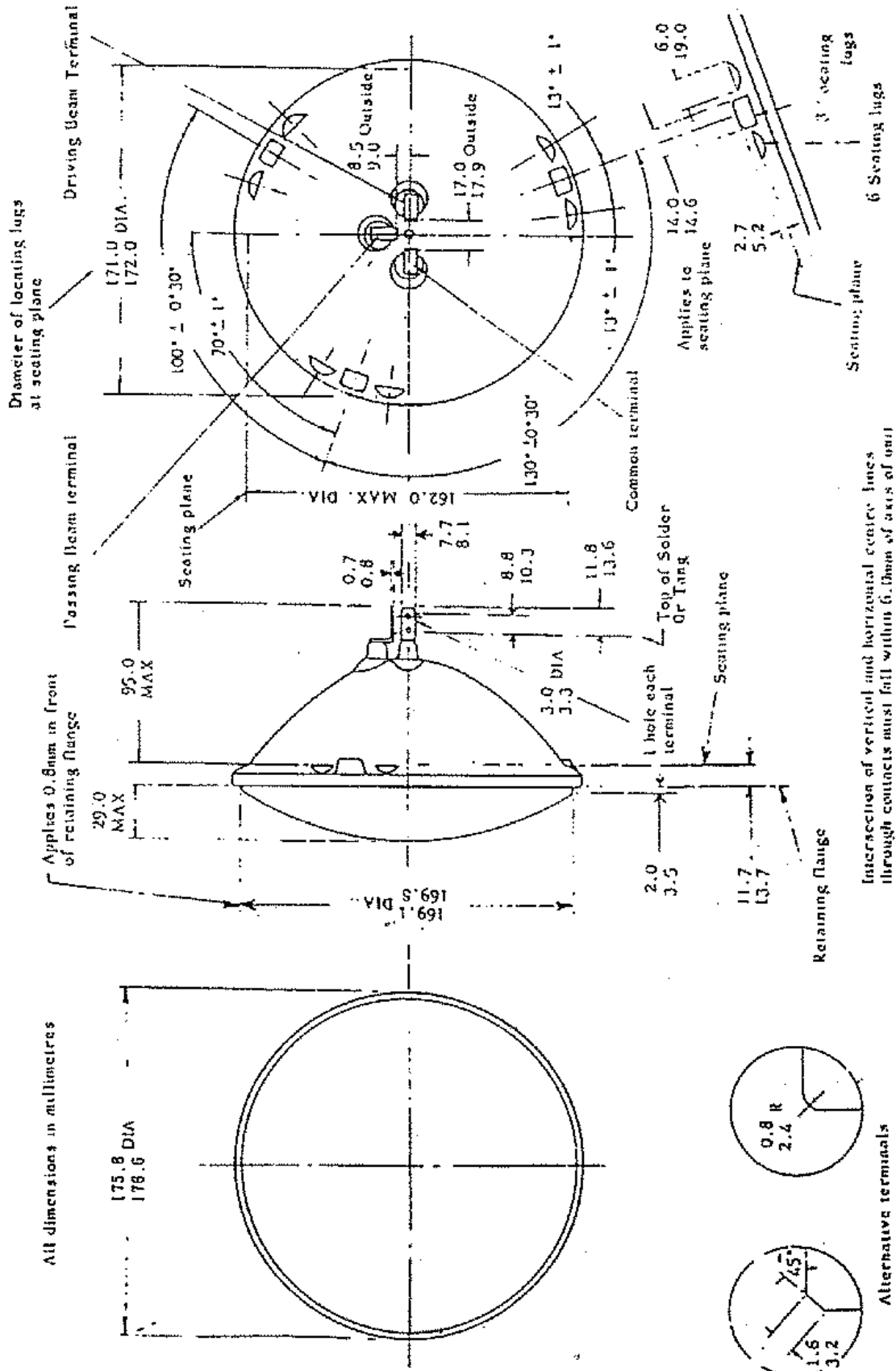
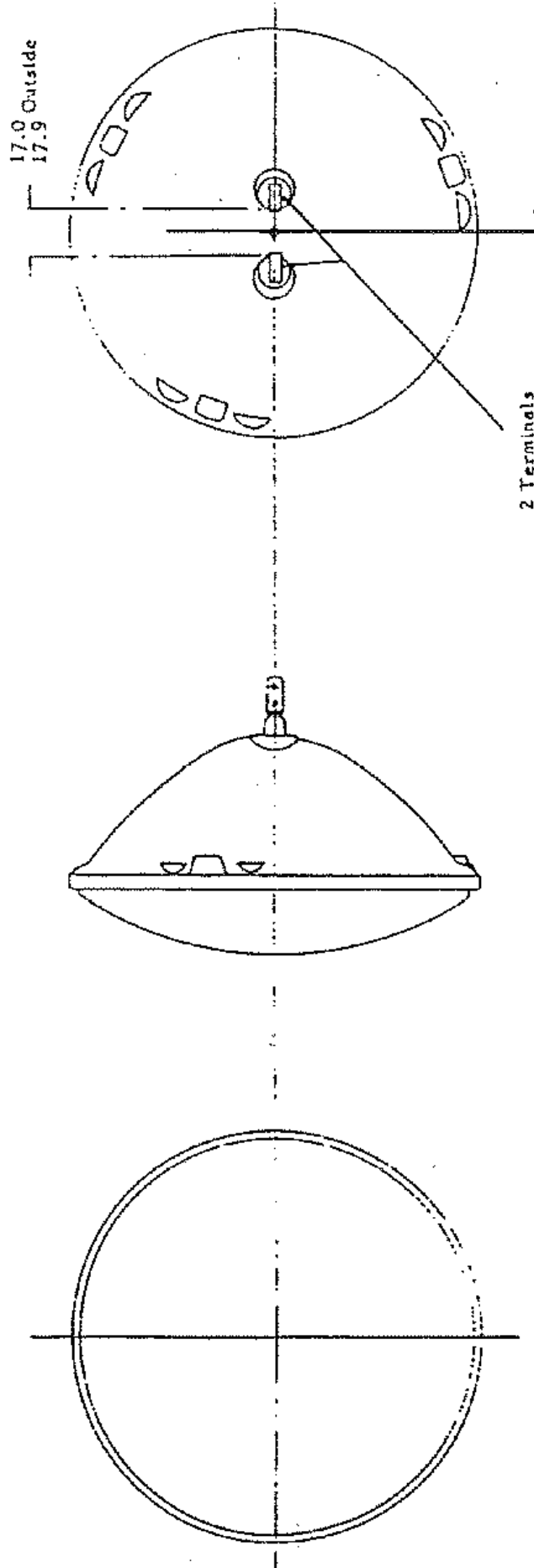

PLATE SD2 - SEALED BEAM HEADLAMP UNIT, 180mm (7in) DIA, TYPE I SINGLE BEAM (DRIVING ONLY)

All dimensions in millimetres



Note: Same as Plate SD2 Sealed Beam Headlamp Unit,  
180mm DIA, except as shown

PLATE SD2 - SEALED BEAM HEADLAMP UNIT, 180mm (7in) DIA, TYPE I SINGLE BEAM (DRIVING ONLY)

All dimensions in millimetres

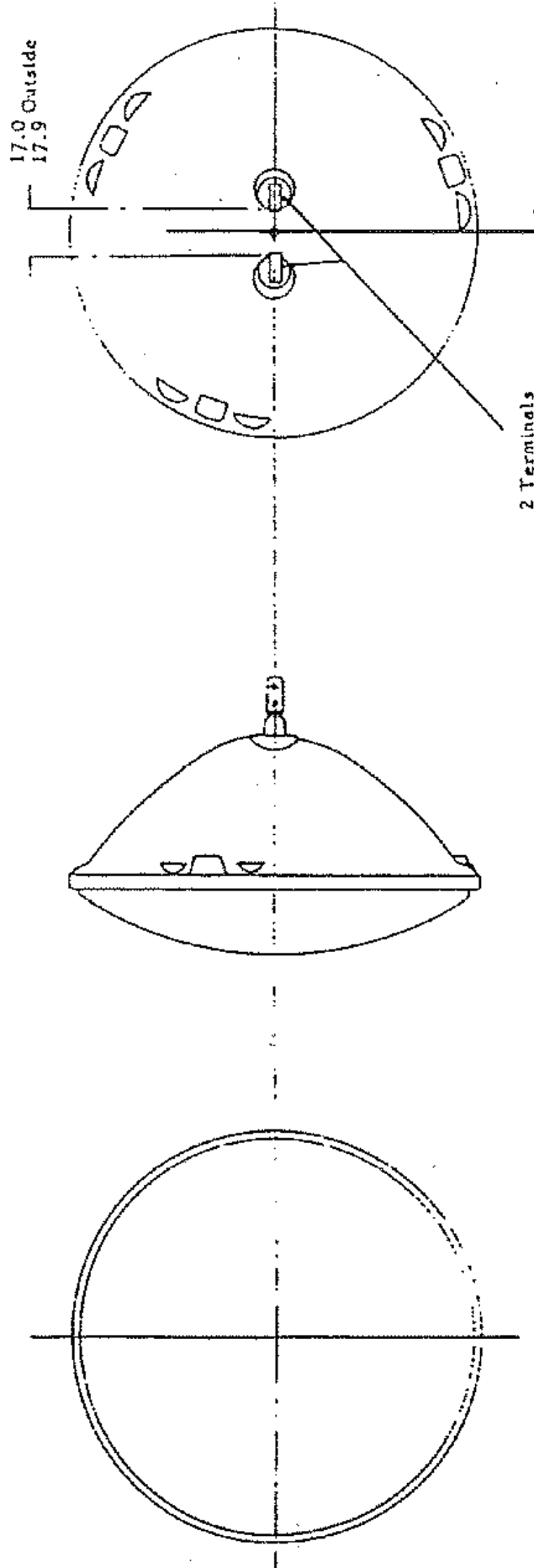

Note: Same as Plate SD2 Sealed Beam Headlamp Unit,  
180mm DIA, except as shown

PLATE S105 - SEALED BEAM HEADLAMP UNIT, 145mm (5.75in) DIA., TYPE 1 SINGLE BEAM (DRIVING ONLY)

All dimensions in millimetres

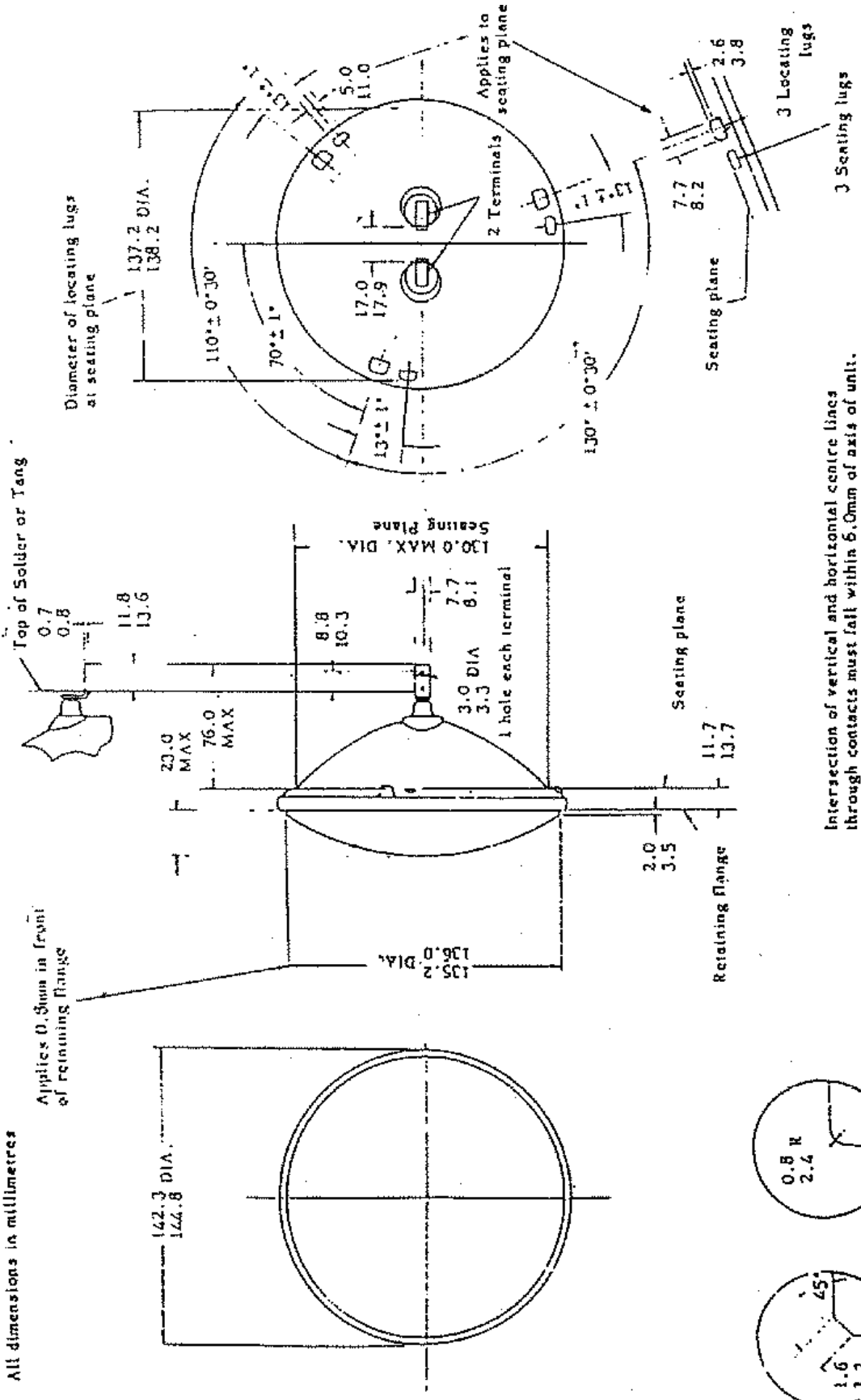

Intersection of vertical and horizontal centre lines through contacts must fall within 6.0mm of axis of unit.

PLATE SB6 - SEALED BEAM HEADLAMP UNIT, 145mm (5.75in) DIA. TYPE 2 DOUBLE BEAM (PASSING & DRIVING)

All dimensions in millimetres

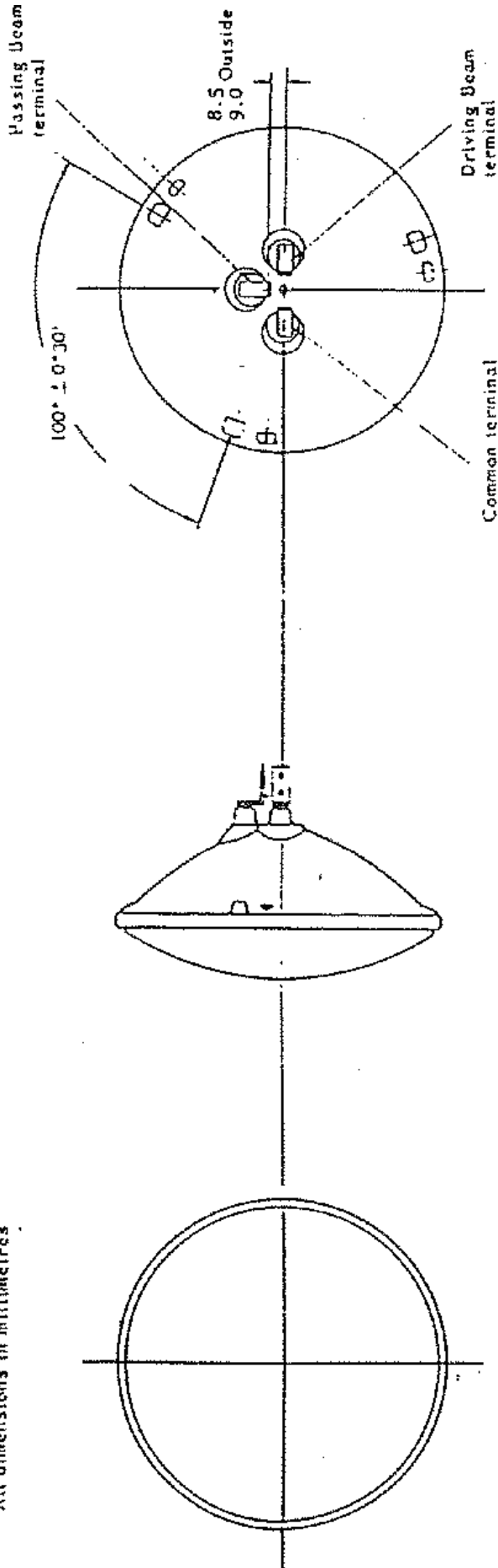

Note: Same as Plate SB5 Sealed Beam Headlamp Unit, 145mm DIA, except as shown

PLATE SB7 - SEALED BEAM HEADLAMP UNIT, 145mm (5.75in) DIA. TYPE 2 SINGLE BEAM (PASSING ONLY)

All dimensions in millimetres

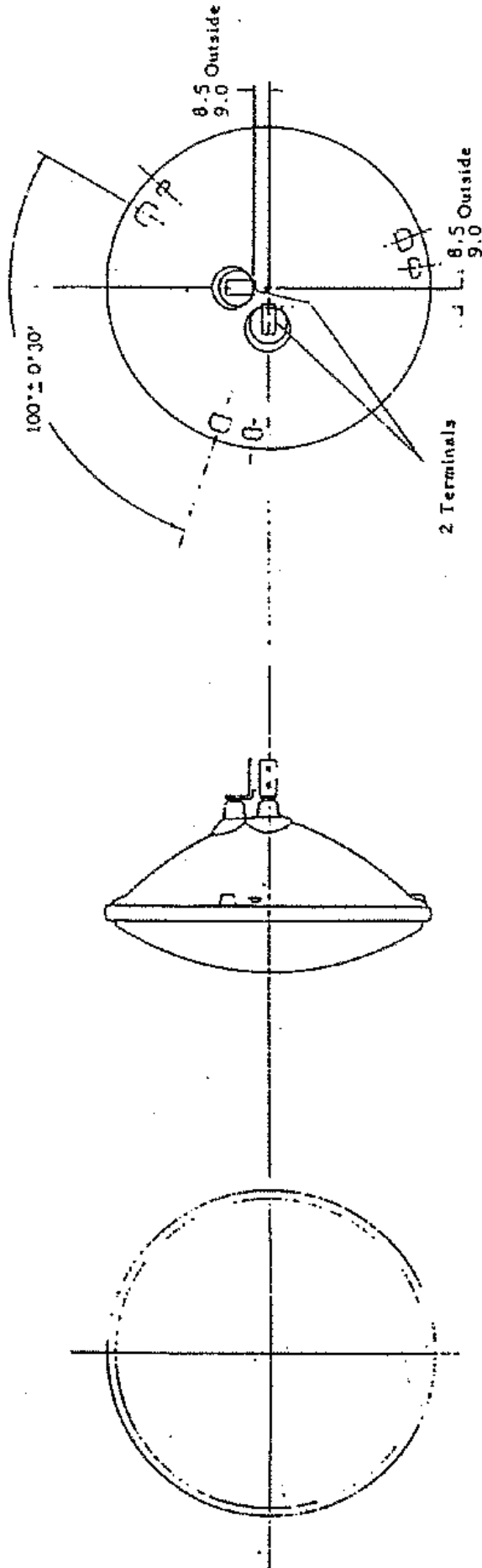

Note: Same as Plate SB5 Sealed Beam Headlamp Unit, 145mm DIA, except as shown

STANDARD EUROPEAN BEAM

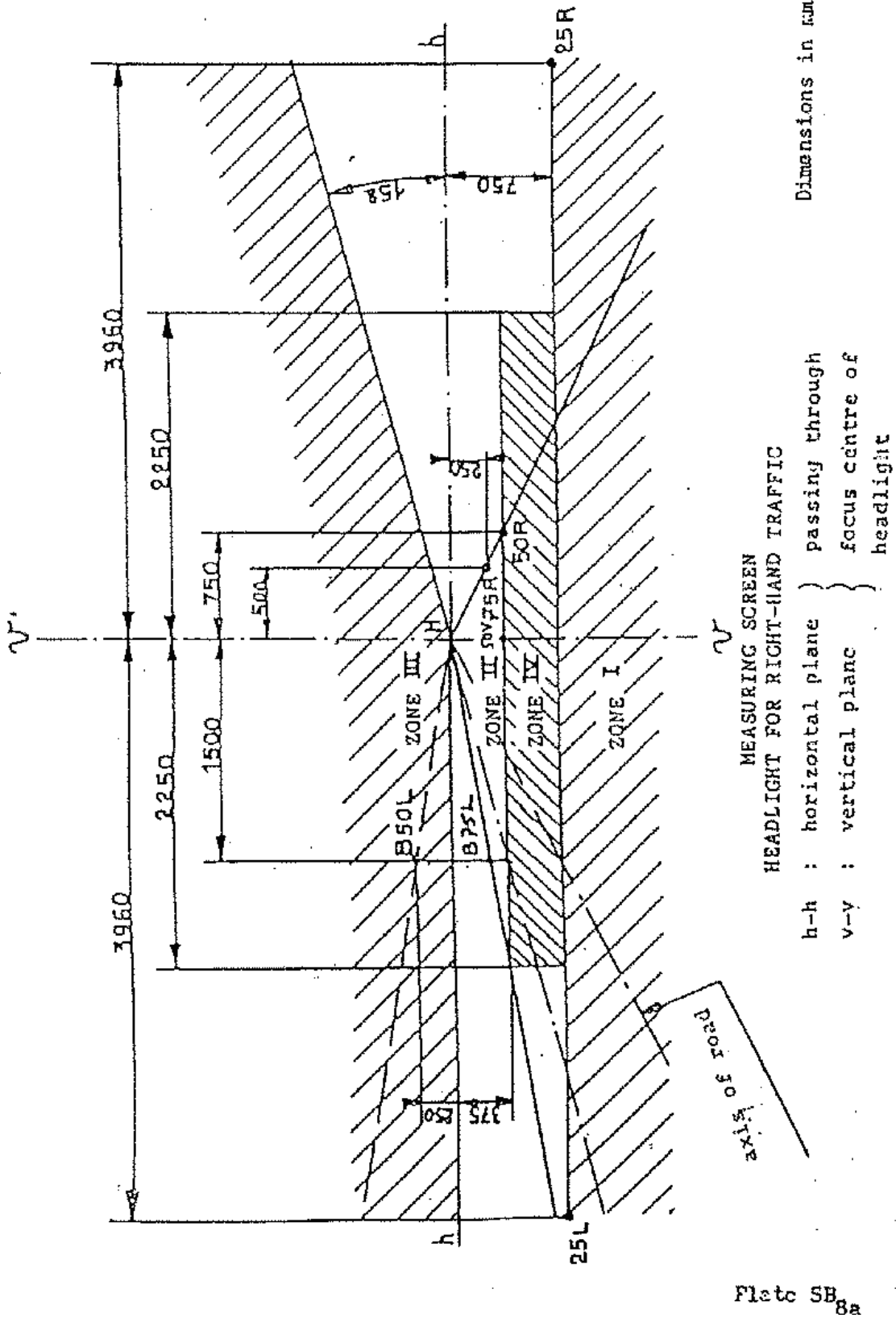

STANDARD EUROPEAN BEAM

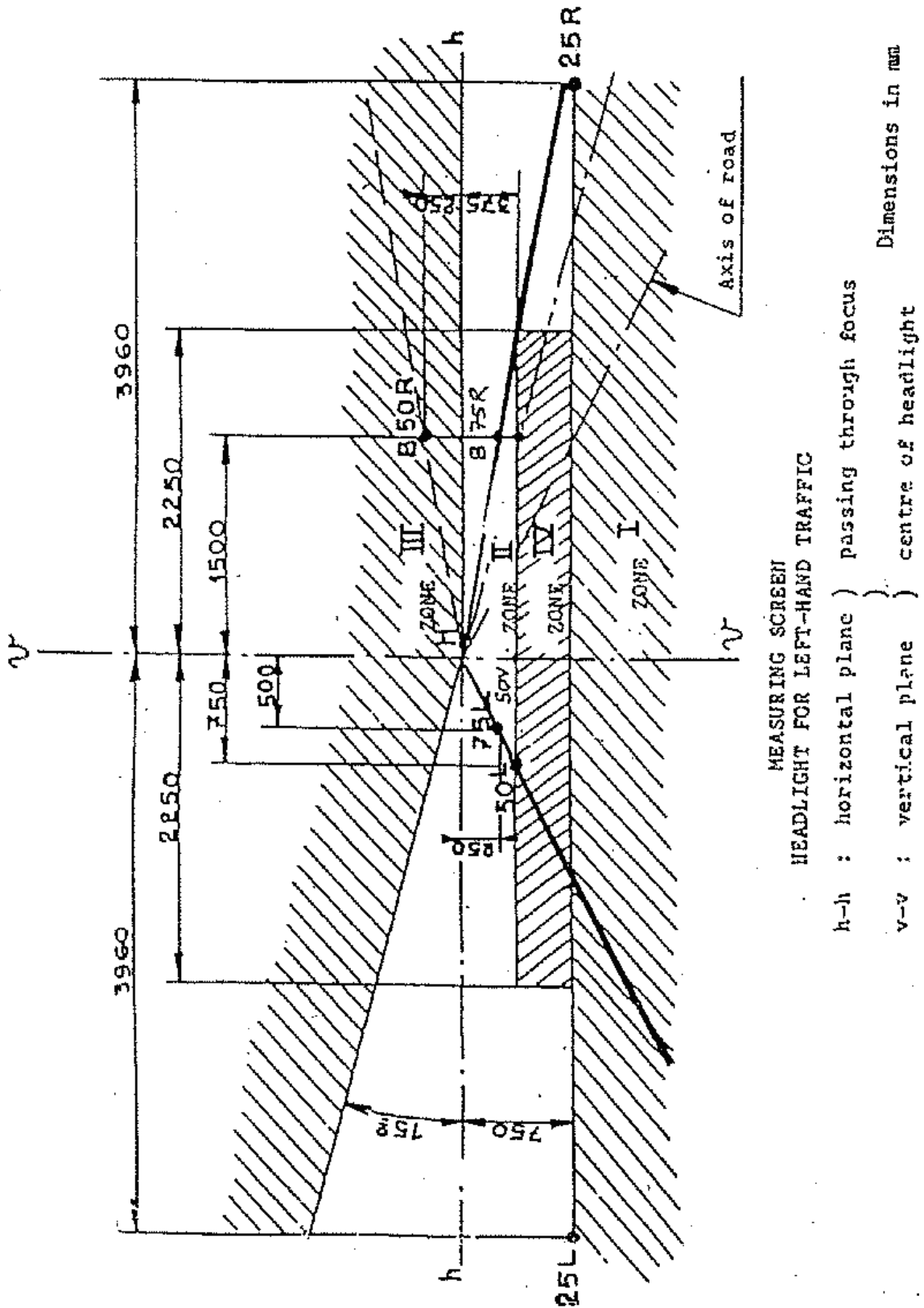

MEASURING SCREEN  
 HEADLIGHT FOR LEFT-HAND TRAFFIC

h-h : horizontal plane ) passing through focus

v-v : vertical plane ) centre of headlight

Dimensions in mm

Plate 88  
 88  
 88

## Annex 5

### TESTS FOR STABILITY OF PHOTOMETRIC PERFORMANCE OF HEADLAMPS IN OPERATION

#### TESTS ON COMPLETE HEADLAMPS

Once the photometric values have been measured according to the prescriptions of this Regulation, in points for  $E_{\max}$  for driving beam and HV, 50 R, B 50 L for passing beam (or HV, 50L, B50R for headlamps designed for left-hand traffic) a complete headlamp sample shall be tested for stability of photometric performance in operation. "Complete headlamps" shall be understood to mean the complete lamp itself including those surrounding body parts and lamps which could influence its thermal dissipation.

#### 1. TEST OF STABILITY OF PHOTOMETRIC PERFORMANCE

The tests shall be carried out in a dry and still atmosphere at an ambient temperature of 23 degrees C +/- 50 degreesC, the complete headlamp being mounted on a base representing the correct installation on the vehicle.

##### 1.1. Clean headlamp

The headlamp shall be operated for 12 hours as described in subparagraph 1.1.1. and checked as prescribed in subparagraph 1.1.2.

##### 1.1.1. Test procedure

The headlamp shall be operated for a period according to the specified time, so that:

- 1.1.1.1. (a) in the case where only one lighting function (driving or passing beam) is to be approved, the corresponding filament is lit for the prescribed time,<sup>2/</sup>
- (b) in the case of a reciprocally incorporated passing lamp and driving lamp (dual filament SB headlamp):

If the applicant declares that the headlamp is to be used with a single filament lit<sup>1/</sup> at a time, the test shall be carried out in accordance with this condition, activating<sup>2/</sup> each specified function successively for half the time specified in paragraph 1.1.;

In all other cases<sup>1/2/</sup> the headlamp, shall be subjected to the following cycle until the time specified is reached:

15 minutes, passing-beam filament lit

5 minutes, all filaments lit.

- (c) in the case of grouped lighting functions all the individual functions shall be lit simultaneously for the time specified for individual lighting functions (a) also taking into account the use of reciprocally incorporated lighting functions (b), according to the manufacturer's specifications.

---

<sup>1/</sup> Should two filaments be simultaneously lit when headlamp flashing is used, this shall not be considered as being normal use of both filaments simultaneously.

<sup>2/</sup> When the tested headlamp is grouped and/or reciprocally incorporated with signalling lamps, the latter shall be lit for the duration of the test. In the case of a direction indicator lamp, it shall be lit in flashing operation mode with an on/off time ratio of approximately one to one.

1.1.1.2. Test voltage

The voltage shall be adjusted so as to supply a wattage 15% (26% for 24 V types) higher than the rated wattage specified in this Regulation for the type(s) of SB headlamp(s) concerned is (are) obtained.

1.1.2. Test results

1.1.2.1. Visual inspection

Once the headlamp has been stabilized to the ambient temperature, the headlamp lens and the external lens, if any, shall be cleaned with a clean, damp cotton cloth. It shall then be inspected visually; no distortion, deformation, cracking or change in colour of either the headlamp lens or the external lens, if any, shall be noticeable.

1.1.2.2. Photometric test

To comply with the requirements of this Regulation, the photometric values shall be verified in the following points:

Passing beam:

50R - B50L - HV for headlamps designed for right-hand traffic

50L - B50R - RV for headlamps designed for left-hand traffic

Driving beam:

Point of  $E_{max}$

Another aiming may be carried out to allow for any deformation of the headlamp base due to heat (the change of the position of the cut-off line is covered in para. 2 of this annex);

a 10% discrepancy between the photometric characteristics and the values measured prior to the test is permissible including the tolerances of the photometric procedure.

1.2. Dirty headlamp

After being tested as specified in subparagraph 1.1. above, the headlamp shall be operated for one hour as described in subparagraph 1.1.1., after being prepared as prescribed in subparagraph 1.2.1., and checked as prescribed in subparagraph.

1.2.1. Preparation of the headlamp

1.2.1.1. Test mixture

1.2.1.1.1 For headlamp with the outside lens in glass:

The mixture of water and a polluting agent to be applied to the headlamp shall be composed of:

9 parts by weight of silica sand with a particle size of 0-100  $\mu m$ ,

1 Part by weight of vegetal carbon dust (beechwood) with a particle size of 0-100  $\mu m$ ,

0.2 part by weight of NaCMC<sup>3/</sup>, and  
an appropriate quantity of distilled water, with a conductivity of < 1 mS/m. The mixture must not be more than 14 days old.

1.2.1.1.2 For headlamp with outside lens in plastic material:

The mixture of water and polluting agent to be applied to the headlamp shall be composed of:

9 parts by weight of silica sand with a particle size of 0-100  $\mu$ m,

1 part by weight of vegetal carbon dust (beechwood) with a particle size of 0-100  $\mu$ m,

0.2 part by weight of NaCMC<sup>3/</sup>,

13 parts by weight of distilled water with a conductivity of < 1 mS/m, and

2 + 1 parts by weight of surface-actant.<sup>4/</sup>

The mixture must not be more than 14 days old.

1.2.1.2. Application of the test mixture to the headlamp

The test mixture shall be uniformly applied to the entire light emitting surface of the headlamp and then left to dry. This procedure shall be repeated until the illumination value has dropped to 15-20% of the values measured for each following point under the conditions described in paragraph I above:

Point of  $E_{\max}$  in driving beam, photometric distribution for a driving/passing lamp,

Point of  $E_{\max}$  in driving beam, photometric distribution for a driving lamp only,

50R and 50V<sup>5/</sup> for a passing lamp only, designed for right-hand traffic,

50L and 50V<sup>5/</sup> for a passing lamp only, designed for left-hand traffic.

1.2.1.3. Measuring equipment

The measuring equipment shall be equivalent to that used during headlamp approval tests.

**2. TEST FOR CHANGE IN VERTICAL POSITION OF THE CUT-OFF LINE UNDER THE INFLUENCE OF HEAT**

This test consists of verifying that the vertical drift of the cut-off line under the influence of heat does not exceed a specified value for an operating passing lamp.

The headlamp tested in accordance with paragraph 1.1., shall be subjected to the test described in 2.1., without being removed from or readjusted in relation to its test fixture.

2.1. Test

---

<sup>3/</sup> NaCMC represents the sodium salt of carboxymethylcellulose, customarily referred to as CMC. The NaCMC used in the dirt mixture shall have a degree of substitution (DS) of 0.6-0.7 and a viscosity of 200-300 cP for a 2% solution at 20 degrees C.

<sup>4/</sup> The tolerance of quantity is due to the necessity of obtaining a dirt that correctly spreads out on all the plastic lens.

<sup>5/</sup> 50 V is situated 375 mm below HV on the vertical line v-v on the screen at 25 m distance.

The test shall be carried out in a dry and still atmosphere at an ambient temperature of 23 degrees C +/- 5 degrees C.

Using a mass production SB headlamp which 'has been aged for at least one hour the headlamp shall be operated on passing beam without being dismantled from or readjusted in relation to its test fixture. (For the purpose of this test, the voltage shall be adjusted as specified in para. 1.1.1.2.). The position of the cut-off line in its horizontal part (between vv and the vertical line passing through point B50L for right-hand traffic or B50R for left-hand traffic) shall be verified 3 minutes (r3) and 60 minutes (r60) respectively after operation.

The measurement of the variation in the cut-off line position as described above shall be carried out by any method giving acceptable accuracy and reproducible results.

## 2.2. Test results

2.2.1. The result expressed in milliradians (mrad) shall be considered as acceptable when the absolute value  $\Delta r_1 = |r_3 - r_{60}|$  recorded on the headlamp is not more than 1.0 mrad ( $\Delta r_1 < 1.0 \text{ mrad}$ ).

2.2.2. However, if this value is more than 1.0 mrad but not more than 1.5 mrad ( $1.0 \text{ mrad} < \Delta r_1 < 1.5 \text{ mrad}$ ) a second headlamp shall be tested as described in 2.1 after being subjected three consecutive times to the cycle as described below, in order to stabilize the position of mechanical parts of the headlamp on a base representative of the correct installation on the vehicle:

Operation of the passing lamp for one hour, (the voltage shall be adjusted as specified in paragraph 1.1.1.2.),

Period of rest for one hour.

The headlamp type shall be considered as acceptable if the mean value of the absolute values  $\Delta r_1$  measured on the first sample and  $\Delta r_{II}$  measured on the second sample is not more than 1.0 mrad

$$\frac{(\Delta r_I + \Delta r_{II})}{2} \leq 1.0 \text{ mrad}$$

## Annex 6

### REQUIREMENTS FOR LAMPS INCORPORATING LENSES OF PLASTIC MATERIAL - TESTING OF LENS OR MATERIAL SAMPLES AND OF COMPLETE LAMPS

#### 1. GENERAL SPECIFICATIONS

- 1.1. The samples supplied pursuant to paragraph 3.2.4. of this Regulation shall satisfy the specifications indicated in paragraphs 2.1 to 2.5 below.
- 1.2. Two out of the five samples of complete lamps supplied pursuant to paragraph 3.2.3. of this Regulation and incorporating lenses of plastic material shall, with regard to the lens material, satisfy the specifications indicated in paragraph 2.6. below.
- 1.3. The samples of lenses of plastic material or samples of material shall be subjected, with the reflector to which they are intended to be fitted (where applicable), to approval tests in the chronological order indicated in table A reproduced in appendix 1 to this annex.
- 1.4. However, if the lamp manufacturer can prove that the product has already passed the tests prescribed in paragraphs 2.1.-2.5. below, or the equivalent tests pursuant to another Regulation, those tests need not be repeated; only the tests prescribed in appendix 1, table B, shall be mandatory.

#### 2. TESTS

##### 2.1. Resistance to temperature changes

##### 2.1.1. Tests

Three new samples (lenses) shall be subjected to five cycles of temperature and humidity (RH = relative humidity) change in accordance with the following programme: 3 hours at 40 degrees C +/- 2 degrees C and 85-95% RH;

1 hour at 23 degrees C +/- 5 degrees C and 60-75% RH;

15 hours at -30 degrees C +/- 2 degrees C;

1 hour at 23 degrees C +/- 5 degrees C and 60-75% RH;

3 hours at 80 degrees C +/- 2 degrees C;

1 hour at 23 degrees C +/- 5 degrees C and 60-75% RH;

Before this test, the samples shall be kept at 23 degrees C +/- 5 degrees C and 60-75% RH for at least four hours.

Note: The periods of one hour at 23 degrees C +/- 5 degrees C shall include the periods of transition from one temperature to another which are needed in order to avoid thermal shock effects.

##### 2.1.2. Photometric measurements

##### 2.1.2.1. Method

Photometric measurements shall be carried out on the samples before and after the test. These measurements shall be made using a standard lamp, at the following points:

B 50 L and 50 R for the passing beam of a passing lamp or a passing/driving lamp (B 50 R and 50 L in the case of headlamps intended for left-hand traffic);

$E_{\max}$  route for the driving beam of a driving lamp or a passing/driving lamp;

#### 2.1.2.2. Results

The variation between the photometric values measured on each sample before and after the test shall not exceed 10% including the tolerances of the photometric procedure.

### 2.2. Resistance to atmospheric and chemical agents

#### 2.2.1. Resistance to atmospheric agents

Three new samples (lenses or samples of material) shall be exposed to radiation from a source having a spectral energy distribution similar to that of a black body at a temperature between 5,500K and 6,000K. Appropriate filters shall be placed between the source and the samples so as to reduce as far as possible radiations with wave lengths smaller than 295 nm and greater than 2,500 nm. The samples shall be exposed to an energetic illumination of 1,200 W/m<sup>2</sup> +/- 200 W/m<sup>2</sup> for a period such that the luminous energy that they receive is equal to 4,500 MJ/m<sup>2</sup> +/- 200 MJ/m<sup>2</sup>. Within the enclosure, the temperature measured on the black panel placed on a level with the samples shall be 50 degrees C +/- 5 degrees C. In order to ensure a regular exposure, the samples shall revolve around the source of radiation at a speed between 1 and 5 1/min.

The samples shall be sprayed with distilled water of conductivity lower than 1 ms/m at a temperature of 23 degrees C +/- 5 degrees C, in accordance with the following cycle:

spraying: 5 minutes;

drying: 25 minutes.

#### 2.2.2. Resistance to chemical agents

After the test described in paragraph 2.2.1. above and the measurement described in paragraph 2.2.3.1. below have been carried out, the outer face of the said three samples shall be treated as described in paragraph 2.2.2.2. with the mixture defined in paragraph 2.2.2.1. below.

##### 2.2.2.1. Test mixture

The test mixture shall be composed of 61.5% n-heptane, 12.5% toluene, 7.5% ethyl tetrachloride, 12.5% trichloroethylene and 6% xylene (volume per cent).

##### 2.2.2.2. Application of the test mixture

Soak a piece of cotton cloth (as per ISO 105) until saturation with the mixture defined in paragraph 2.2.2.1. above and, within 10 seconds, apply it for 10 minutes to the outer face of the sample at a pressure of 50 N/cm<sup>2</sup>, corresponding to an effort of 100 N applied on a test surface of 14 x 14 mm.

During this 10-minute period, the cloth pad shall be soaked again with the mixture so that the composition of the liquid applied is continuously identical with that of the test mixture prescribed.

During the period of application, it is permissible to compensate the pressure applied to the sample in order to prevent it from causing cracks.

#### 2.2.2.3. Cleaning

At the end of the application of the test mixture, the samples shall be dried in the open air and then washed with the solution described in paragraph 2.3. (Resistance to detergents) 23 degrees C +/- 5 degrees C.

Afterwards the samples shall be carefully rinsed with distilled water containing not more than 0.2% impurities at 23 degrees C +/- 5 degrees C and then wiped off with a soft cloth.

#### 2.2.3. Results

##### 2.2.3.1. After the test of resistance to atmospheric agents, the outer face of the samples shall be free from cracks, scratches, chipping and deformation, and the mean variation in transmission

$$\Delta t = \frac{T_2 - T_3}{T_2}$$

measured on the three samples according to the procedure described in appendix 2 to this annex shall not exceed 0.020 ( $\Delta t_m < 0.020$ ).

##### 2.2.3.2. After the test of resistance to chemical agents, the samples shall not bear any traces of chemical staining likely to cause a variation of flux diffusion, whose mean variation

$$\Delta d = \frac{T_5 - T_4}{T_2}$$

measured on the three samples according to the procedure described in appendix 2 to this annex shall not exceed 0.020 ( $\Delta d_m < 0.020$ ).

#### 2.3. Resistance to detergents and hydrocarbons

##### 2.3.1. Resistance to detergents

The outer face of three samples (lenses or samples of material) shall be heated to 50 degrees C +/- 5 degrees C and then immersed for five minutes in a mixture maintained at 23 degrees C +/- 5 degrees C and composed of 99 parts distilled water containing not more than 0.02% impurities and one part alkylaryl sulphate.

At the end of the test, the samples shall be dried at 50 degrees C +/- 5 degrees C. The surface of the samples shall be cleaned with a moist cloth.

##### 2.3.2. Resistance to hydrocarbons

The outer face of these three samples shall then be lightly rubbed for one minute with a cotton cloth soaked in a mixture composed of 70% n-heptane and 30% toluene (volume per cent), and shall then be dried in the open air.

##### 2.3.3. Results

After the above two tests have been performed successively, the mean value of the variation in transmission

$$\Delta t = \frac{T_2 - T_3}{T_2}$$

measured on the three samples according to the procedure described in appendix 2 to this annex shall not exceed 0.010 ( $\Delta t_m < 0.010$ ).

## 2.4. Resistance to mechanical deterioration

### 2.4.1. Mechanical deterioration method

The outer face of the three new samples (lenses) shall be subjected to the uniform mechanical deterioration test by the method described in appendix 3 to this annex.

### 2.4.2. Results

After this test, the variations: in transmission:

$$\Delta t = \frac{T_2 - T_3}{T_2}$$

and in diffusion:

$$\Delta d = \frac{T_5 - T_4}{T_2}$$

shall be measured according to the procedure described in appendix 2 in the area specified in paragraph 2.2.4. above. The mean value of the three samples shall be such that:  $\Delta t_m < 0.100$ ;

$\Delta d_m < 0.050$ .

## 2.5. Test of adherence of coatings, if any

### 2.5.1. Preparation of the sample

A surface of 20 mm x 20 mm in area of the coating of a lens shall be cut with a razor blade or a needle into a grid of squares approximately 2 mm x 2 mm. The pressure on the blade or needle shall be sufficient to cut at least the coating.

### 2.5.2. Description of the test

Use an adhesive tape with a force adhesion of 2 N/(cm of width) +/- 20% measured under the standardized conditions specified in appendix 4 to this annex. This adhesive tape, which shall be at least 25 mm wide, shall be pressed for at least five minutes to the surface prepared as prescribed in paragraph 2.5.1.

Then the end of the adhesive tape shall be loaded in such a way that the force of adhesion to the surface considered is balanced by a force perpendicular to that surface. At this stage, the tape shall be torn off at a constant speed of 1.5 m/s +/- 0.2 m/s.

### 2.5.3. Results

There shall be no appreciable impairment of the gridded area. Impairments at the intersections between squares or at the edges of the cuts shall be permitted, provided that the impaired area does not exceed 15 % of the gridded surface.

## 2.6. Tests of the complete lamp incorporating a lens of plastic material

### 2.6.1. Resistance to mechanical deterioration of the lens surface

#### 2.6.1.1. Tests

The lens of lamp sample No. 1 shall be subjected to the test described in paragraph 2.4.1. above.

2.6.1.2. Results

After the test, the results of photometric measurements carried out on the lamp in accordance with this Regulation shall not exceed by more than 30% the maximum values prescribed at points B 50 L and HV and not be more than 10% below the minimum values prescribed at point 75 R (in the case of headlamps intended for left- hand traffic, the points to be considered are B 50 R, HV and 75 L).

2.6.2. Test of adherence of coatings, if any

The lens of lamp sample No. 2 shall be subjected to the test described in paragraph 2.5. above.

**3. VERIFICATION OF THE CONFORMITY OF PRODUCTION**

3.1. With regard to the materials used for the manufacture of lenses, the lamps of a series shall be recognized as complying with this Regulation if:

3.1.1. After the test for resistance to chemical agents and the test for resistance to detergents and hydrocarbons, the outer face of the samples exhibits no cracks, chipping or deformation visible to the naked eye (see paras. 2.2.2., 2.3.1. and 2.3.2.);

3.1.2. After the test described in paragraph 2.6.1.1., the photometric values at the points of measurement considered in paragraph 2.6.1.2. are within the limits prescribed for conformity of production by this Regulation.

3.2. If the test results fail to satisfy the requirements, the tests shall be repeated on another sample of headlamps selected at random.

**Annex 6 - Appendix 1**  
**CHRONOLOGICAL ORDER OF APPROVAL TESTS**

**A. Tests on plastic materials (lenses or samples of material supplied pursuant to paragraph 3.2.4. of this Regulation)**

Tests	Lenses or samples of material						Lenses						
	1	2	3	4	5	6	7	8	9	10	11	12	13
1. 1. Limited photometry (para. 2.1.2.)										X	X	X	
1. 1. 1. Temperature change (para. 2. 1. L)										X	X	X	
1. 1.2. Limited photometry (para. 2.1.1)										X	X	X	
1.2. 1. Transmission measurement	X	X	X	X	X	X	X	X	X				
1.2.2. Diffusion measurement	X	X	X				X	X	X				
1.3. Atmospheric agents (para. 2.2.1.)	X	X	X										
1. 3. 1. Transmission measurement	X	X	X										
1.4. Chemicals agents (para. 2.2.2)	X	X	X										
1.4. 1. Diffusion measurement	X	X	X										
1.5. Detergents (para. 2.3. 1 )				X	X	X							
1.6. Hydrocarbons (para. 2.3.2)				X	X	X							
1.6. 1. Transmission measurement				X	X	X							
1.7. Deterioration (para. 2.4.1.)													
1.7.1. Transmission measurement							X	X	X				
1.7.2. Diffusion measurement							X	X	X				
1.8. Adherence (para. 2.5)							X	X	X				X

**B. Tests on complete lamps (supplied pursuant to paragraph 3.2.3 of this Regulation)**

Tests	Complete lamp Sample No.	
	1	2
2. 1. Deterioration (para. 2.6. 1.1)	X	
2.2. Photometry (para. 2.6.1.2)	X	
2.3. Adherence (para. 2.6.2)	X	X

## Annex 6 - Appendix 2

### METHOD OF MEASUREMENT OF THE DIFFUSION AND TRANSMISSION OF LIGHT

#### 1. EQUIPMENT (see figure)

The beam of a collimator K with a half divergence  $\beta/2 = 17.4 \times 10^{-4}$  rd is limited by

a diaphragm  $D_T$  with an opening of 6 nun against which the sample stand is placed.

A convergent achromatic lens  $L_2$  corrected for spherical aberrations, links the diaphragm

$D_T$  ith the receiver R; the diameter of the lens  $L_2$  shall be such that it does not diaphragm he light diffused by the sample in a cone with a half top angle of  $\beta/2 = 14$ degrees. An annular diaphragm  $D_D$  with angles  $\alpha/2 = 1$  degree and  $\alpha/2_{\max} = 12$ degrees is placed in an image focal plane of the lens  $L_2$ .

The non-transparent central part of the diaphragm is necessary in order to eliminate the light arriving directly from the light source. It shall be possible to remove the central part of the diaphragm from the light beam in such a manner that it returns exactly to its original position.

The distance  $L_2 D_T$  and the focal length  $F_2^{1/}$  of the lens  $L_2$  shall be so chosen that the image of  $D_T$  completely covers the receiver R.

When the initial incident flux is referred to 1,000 units, the absolute precision of each reading shall be better than 1 unit.

#### 2. MEASUREMENTS

The following readings shall be taken:

Reading	With sample	With central part of $D_D$	Quantity represented
$T_1$	No	No	Incident flux in initial reading
$T_2$	Yes (before test)	No	Flux transmitted by the new material in a field of 24degrees C
$T_3$	Yes (after test)	Yes	Flux transmitted by the tested material in a field of 24degrees C
$T_4$	Yes (before test)	Yes	Flux diffused by the new material
$T_5$	Yes (after test)	Yes	Flux diffused by the tested material

<sup>1/</sup> For  $L_2$  it is recommended to use a focal distance of about 80 mm.

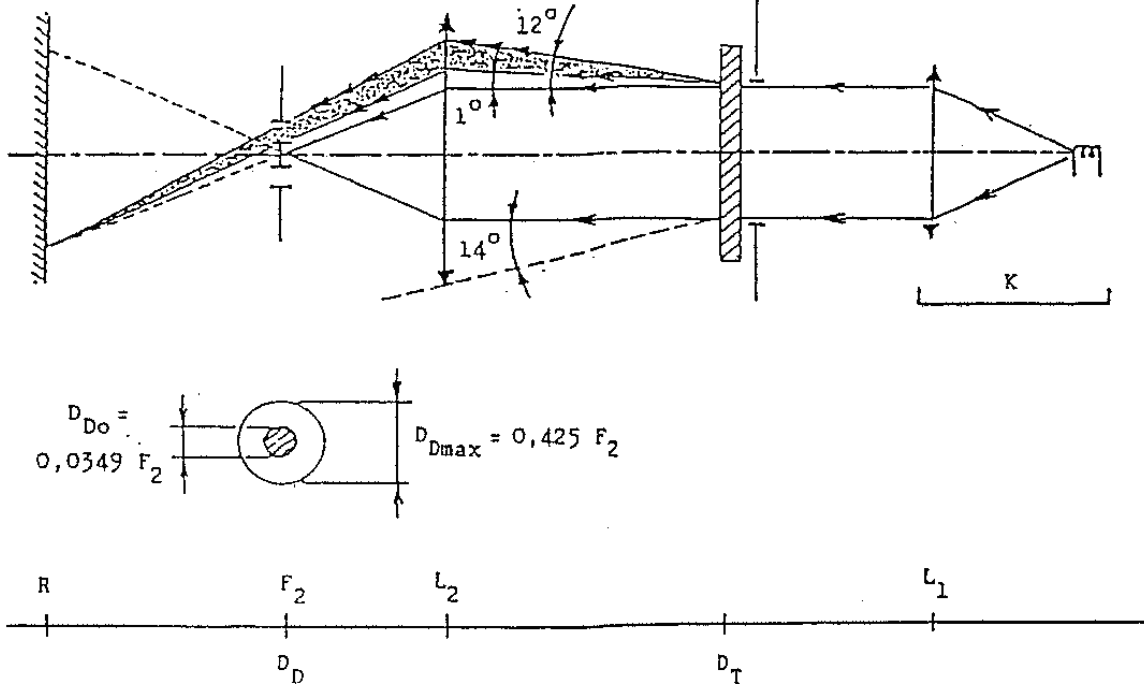

## **Annex 6 - Appendix 3**

### **SPRAY TESTING METHOD**

#### **1. Test equipment**

##### **1.1. Spray gun**

The spray gun used shall be equipped with a nozzle 1.3 mm in diameter allowing a liquid flow rate of 0.24 +/- 0.02 l/minute at an operating pressure of 6.0 bars - 0, + 0.5 bar. Under these operation conditions the fan pattern obtained shall be 170 mm +/- 50 mm in diameter on the surface exposed to deterioration, at a distance of 380 mm +/- 10 mm from the nozzle.

##### **1.2. Test mixture**

The test mixture shall be composed of:

Silica sand of hardness 7 on the Mohr scale, with a grain size between 0 and 0.2 mm and an almost normal distribution, with an angular factor of 1.8 to 2;

Water of hardness not exceeding 205 g/m<sup>3</sup> for a mixture comprising 25 g of sand per litre of water.

#### **2. Test**

The outer surface of the lamp lenses shall be subjected once or more than once to the action of the sand jet produced as described above. The jet shall be sprayed almost perpendicular to the surface to be tested.

The deterioration shall be checked by means of one or more samples of glass placed as a reference near the lenses to be tested. The mixture shall be sprayed until the variation in the diffusion of light on the sample or samples measured by the method described in appendix 2, is such that:  $\Delta \pm$

$$\Delta d = \frac{T5 - T4}{T2} = 0.0250 \pm 0.0025$$

Several reference samples may be used to check that the whole surface to be tested has deteriorated homogeneously.

## **Annex 6 - Appendix 4**

### **ADHESIVE TAPE ADHERENCE TEST**

#### **1. PURPOSE**

This method allows to determine under standard conditions the linear force of adhesion of an adhesive tape to a glass plate.

#### **2. PRINCIPLE**

Measurement of the force necessary to unstick an adhesive tape from a glass plate at an angle of 90 degrees.

#### **3. SPECIFIED ATMOSPHERIC CONDITIONS**

The Ambient conditions shall be at 23 degrees C +/- 5 degrees C and 65 +/- 15 % relative humidity (RH).

#### **4. TEST PIECES**

Before the test, the sample roll of adhesive tape shall be conditioned for 24 hours in the specified atmosphere (see para. 3 above).

Five test pieces each 400 mm long shall be tested from each roll. These test pieces shall be taken from the roll after the first three turns were discarded.

#### **5. PROCEDURE**

The test shall be under the ambient-conditions specified in paragraph 3.

Take the five test pieces while unrolling the tape radially at a speed of approximately 300 mm/s, then apply them within 15 seconds in the following manner:

Apply the tape to the glass plate progressively with a slight lengthwise rubbing movement of the finger, without excessive pressure, in such a manner as to leave no air bubble between the tape and the glass plate.

Leave the assembly in the specified atmospheric conditions for 10 minutes.

Unstick about 25 mm of the test piece from the plate in a plane perpendicular to the axis of the test piece.

Fix the plate and fold back the free end of the tape at 90 degrees. Apply force in such a manner that the separation line between the tape and the plate is perpendicular to this force and perpendicular to the plate.

Pull to unstick at a speed of 300 mm/s +/- 30 mm/s and record the force required.

#### **6. RESULTS**

The five values obtained shall be arranged in order and the median value taken as the result of the measurement. This value shall be expressed in Newtons per centimetre of width of the tape.

## Annex 7

### MINIMUM REQUIREMENTS FOR SAMPLING BY AN INSPECTOR

#### 1. GENERAL

1.1. The conformity requirements shall be considered satisfied from a mechanical and a geometric standpoint, in accordance with the requirements of this Regulation, if any, if the difference do not exceed inevitable manufacturing deviations.

1.2. With respect to photometric performance, the conformity of mass-produced headlamps shall not be contested if, when testing photometric performances of any headlamp chosen at random:

1.2.1. no measured value deviates unfavorable by more than 20% from the values prescribed in this Regulation.

For values B 50 L (or R) and Zone III the maximum deviation may be respectively:

B 50 L (or R):	0.2	1x equivalent	20%
	0.3	1x equivalent	30%
Zone III	0.3	1x equivalent	20%
	0.45	1x equivalent	30%

1.2.2. or if

1.2.2.1. for the passing beam, the values prescribed in this regulation are met at HV (with a tolerance of 0.2 1x) and related to the that aiming at least one points of each area delimited on the measuring screen (with a tolerance of 0.1 1x), 75 R (or L), 25 R, 25 L, and in the entire area of zone IV which is not more than 22.5 cm above line 25 R and 25 L;

1.2.2.2. and if, for the driving beam, HV being situated within the isolux 0.75 E max , a tolerance of + 20% for maximum values and - 20 % for minimum values is observed for the photometric values at any measuring point specified in paragraph 8.10. of this

1.2.3. If the results of the tests described above do not meet the requirements, the alignment of the headlamp may be changed, provided that axis of the beam is not displaces laterally by more than 1 degrees to the right or left.<sup>10/</sup>

1.2.4. Headlamps with apparent defects are disregarded.

1.2.5. The reference mark is disregarded.

1.3. The chromaticity coordinates shall be complied with.

The photometric performance of a headlamp emitting selective yellow light shall be the values contained in this Regulation multiplied by 0.84.

#### 2. FIRST SAMPLING

In the first sampling four headlamps are selected at random. The first sample of two is marked A, the second samples of two is marked B.

2.1. The conformity is not contested

---

<sup>10/</sup> See the corresponding footnote in the text of the Regulation.

2.1.1. Following the sampling procedure shown in Figure 1 of this annex the conformity of mass-produced headlamps shall not be contested if the deviation of the measured values of the headlamps in the unfavorable directions are:

2.1.1.1. sample A

A1:	one headlamp	0 %
	one headlamp not more than	20 %
A2:	both headlamp more than	0 %
	but not more than	20 %

go to sample B

2.1.1.2. sample B

B1:	both headlamps	0 %
-----	----------------	-----

2.1.2. or if the conditions of paragraph 1.2.2. for sample A are fulfilled.

2.2. The conformity is contested

2.2.1. Following the sampling procedure shown in Figure 1 of this annex the conformity of mass-produced headlamps shall be contested and the manufacturer requested to mark his production meet the requirement (alignment) if the deviations of the measured values of the headlamps are:

2.2.1.1. sample A

A3:	one headlamp not more than	20 %
	one headlamp more than	20 %
	but not more than	30 %

2.2.1.2. sample B

B2: in the case of A2

	one headlamp more than	0 %
	but not more than	20 %
	one headlamp not more than	20 %

B3: in the case of A2

	one headlamp	0 %
	one headlamp more than	20 %
	but not more than	30 %

2.2.2. or if the conditions of paragraph 1.2.2. for sample A are not fulfilled.

2.3. Approval withdraw

Conformity shall be contested and paragraph 10 applied if, following the sampling procedure in Figure of this annex, the deviations of the measured values of the headlamps are:

---

2.3.1.	sample A	
A4:	one headlamp not more than	20 %
	one headlamp more than	30 %
A5:	both headlamps more than	20 %
2.3.2.	sample B	
B4: in the case of A2		
	one headlamp more than	0 %
	but not more than	20 %
	one headlamp more than	20 %
B5: in the case of A2		
	both headlamps more than	20 %
B6: in the case of A2		
	one headlamp	0 %
	one headlamp more than	30 %
2.3.3.	or if the conditions of paragraph 1.2.2. for samples A and B are not fulfilled.	

### 3. REPEATED SAMPLING

In the case of A3, B2 B3 a repeated sampling, third sample C of two headlamps and fourth sample D of two headlamps, selected from stock manufactured after alignment, is necessary within two months time after the notification.

#### 3.1. The conformity is not contested

3.1.1. Following the sampling procedure shown in Figure 1 of this annex the conformity of mass-produced headlamps shall not be contested if the deviations of the measured values of the headlamps are:

##### 3.1.1.1. sample C

C1:	one headlamp	0 %
	one headlamp not more than	20 %
C2:	both headlamps more than	0 %
	but not more than	20 %

go to sample D

##### 3.1.1.2. sample D

D1: in the case of C2		
	both headlamps	0 %

3.1.2. or if the conditions of paragraph 1.2.2. for sample C are fulfilled.

#### 3.2. The conformity is contested

3.2.1. Following the sampling procedure shown in Figure 1 of this annex the conformity of mass-produced headlamps shall be contested and the manufacturer requested to

mark his production meet the requirements (alignment) if the deviations If the measured values of the headlamps are:

- 3.2.1.1. sample D
- D2: in the case of C2
- |                            |      |
|----------------------------|------|
| one headlamp more than     | 0 %  |
| but not more than          | 20 % |
| one headlamp not more than | 20 % |

3.2.1.2. or if the conditions of paragraph 1.2.2. for sample C are not fulfilled:

### 3.3. Approval withdrawn

Conformity shall be contested and paragraph 13 applied if, following the sampling procedure in Figure 1 of this annex, the deviations of the measured values of the headlamps are:

- 3.3.1. sample C
- |                                |      |
|--------------------------------|------|
| C3: one headlamp not more than | 20 % |
| one headlamp more than         | 20 % |
| C4: both headlamps more than   | 20 % |

- 3.3.2. sample D
- D3: in the case of C2
- |                             |     |
|-----------------------------|-----|
| one headlamp 0 or more than | 0 % |
|-----------------------------|-----|

3.3.3. or if the conditions of paragraph 1.2.2. for samples C and D are not fulfilled.

## 4. **CHANGE OF THE VERTICAL POSITION OF THE CUT-OFF LINE**

With respect to the verification of the change in vertical positions of the cut-off line under the influence of heat, the following procedure shall be applied:

One of the headlamps of sample A after sampling procedure in Figure 1 of this annex shall be tested according to the procedure described in paragraph 2.1. of annex 5 after being subjected three consecutive times to the cycle described in paragraph 2.2.2. of annex 5.

The headlamps shall be considered as acceptable if  $\Delta r$  does not exceed 1.5 mrad.

If this value exceeds 1.5 mrad but is not more than 2.0 mrad, the second headlamp of sample A shall be subjected to the test after which the mean of the absolute values recorded in both samples shall not exceed 1.5 mrad.

However, if this value of 1.5 mrad on sample A is not complied with, the two headlamps of sample B shall be subjected to the same procedure and the value of  $\Delta r$  for each of them shall not exceed 1.5 mrad.

**Figure 1**

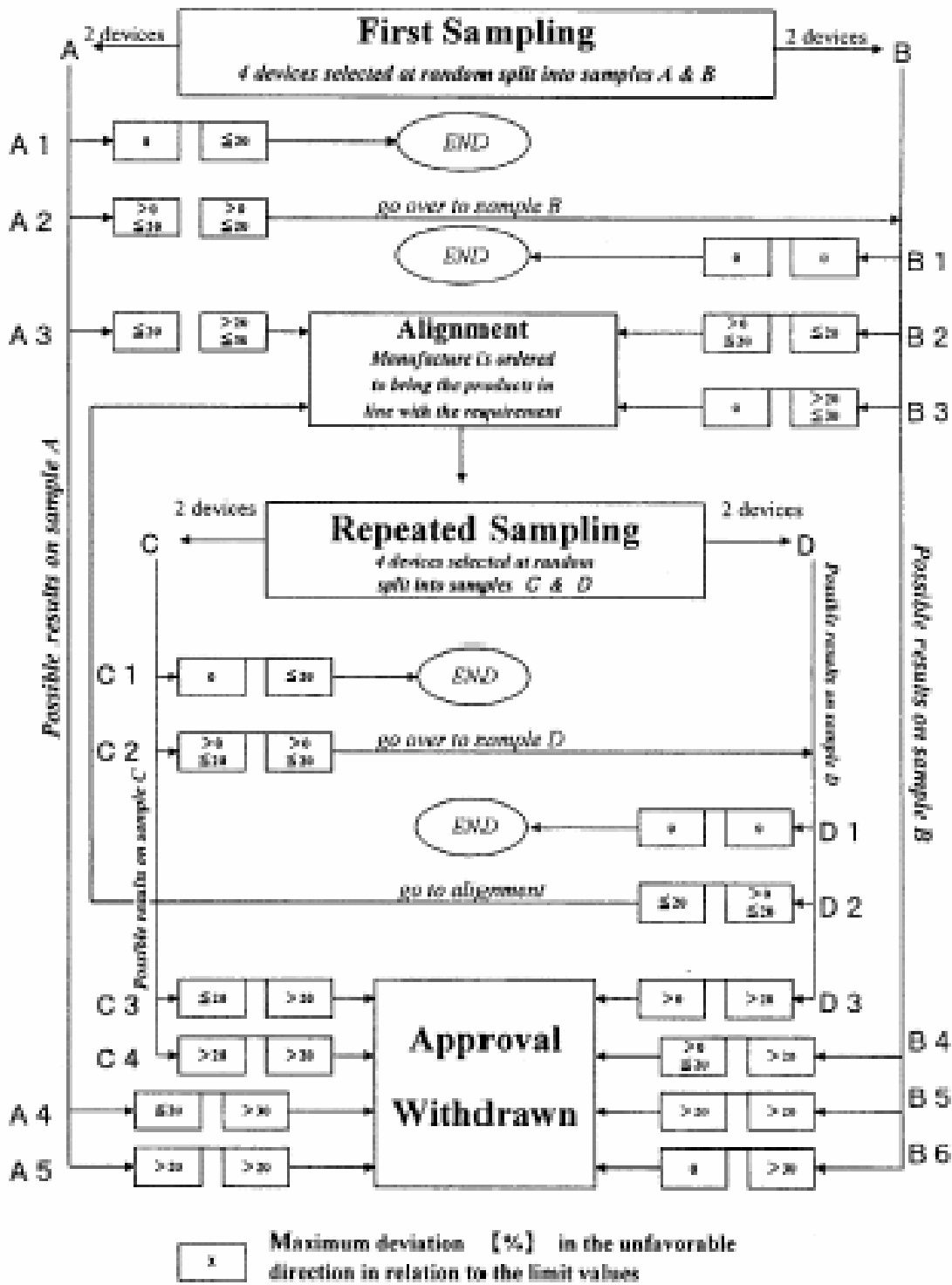

## **APPENDIX C**

### **UN REGULATION No. 8/04**

**UNIFORM PROVISIONS CONCERNING THE APPROVAL OF MOTOR VEHICLE HEADLAMPS EMITTING AN ASYMMETRICAL PASSING BEAM OR A DRIVING BEAM OR BOTH AND EQUIPPED WITH HALOGEN FILAMENT LAMPS (H<sub>1</sub>, H<sub>2</sub>, H<sub>3</sub>, HB<sub>3</sub>, HB<sub>4</sub>, H<sub>7</sub>, H<sub>8</sub> and/or H1R1)**

**NOTE:** In view of recent changes to the Regulation, text containing Supplement 10 has not been incorporated in the main Regulation document. Supplement 10 has been placed between pages 186 to 226. Changes in the texts of Supplements 8 and 9 will be incorporated into the Regulation when the consolidated document is available from the UN-ECE.

## **Regulation No. 8**

### **UNIFORM PROVISIONS CONCERNING THE APPROVAL OF MOTORVEHICLE HEADLAMPS EMITTING AN ASYMMETRICAL PASSING BEAM OR A DRIVING BEAM OR BOTH AND EQUIPPED WITH HALOGEN FILAMENT LAMPS**

**(H<sub>1</sub>, H<sub>2</sub>, H<sub>3</sub>, HB<sub>3</sub>, HB<sub>4</sub>, H<sub>7</sub>, H<sub>8</sub>, H<sub>9</sub>, HIR1 and/or HIR2)**

#### **CONTENTS**

##### **REGULATION A.**

###### **ADMINISTRATIVE PROVISIONS**

- Scope
- 1. Definitions
- 2. Applications for approval of a headlamp
- 3. Markings
- 4. Approval

###### **B. TECHNICAL REQUIREMENTS FOR HEADLAMPS**

- 5. General specifications
- 6. Illumination
- 7. Requirements concerning coloured lenses and filters
- 8. Gauging of discomfort
- 9. Standard headlamp
- 10. Observation concerning colour

###### **C. FURTHER ADMINISTRATIVE PROVISIONS**

- 11. Modifications and extension of approval of a type of headlamp
- 12. Conformity of production
- 13. Penalties for non-conformity of production
- 14. Production definitely discontinued
- 15. Names and addresses of technical services responsible for conducting approval tests and of administrative departments

##### **ANNEXES**

- Annex 1: Communication concerning the approval (or extension or refusal or withdrawal of approval or production definitely discontinued) of a type of headlamp pursuant to Regulation No. 8
- Annex 2: Verification of conformity of production of headlamps equipped with H<sub>1</sub>, H<sub>2</sub>, H<sub>3</sub>, HB<sub>3</sub>, HB<sub>4</sub>, H<sub>7</sub>, H<sub>8</sub>, H<sub>9</sub>, HIR1 and/or HIR2 filament lamps
- Annex 3: Examples of arrangements of approval marks
- Annex 4: Measuring screen
- Annex 5: Tests for stability of photometric performance of headlamps in operation
- Annex 6: Requirements for lamps incorporating lenses of plastic material-testing of lens or material samples and of complete lamps
- Annex 7: Minimum requirements for sampling by an inspector

## A. ADMINISTRATIVE PROVISIONS

### SCOPE <sup>1/</sup>

This Regulation applies to motor vehicle headlamps which may incorporate lenses of glass or plastic material.

### 1. DEFINITIONS

For the purpose of this Regulation,

- 1.1. "Lens" means the outermost component of the headlamp (unit) which transmits light through illuminating surface;
- 1.2. "Coating" means any product or products applied in one or more layers to the outer face of a lens;
- 1.3. "Headlamps of different types" are headlamps which differ in such essential respects as:
  - 1.3.1. the trade name or mark;
  - 1.3.2. the characteristics of the optical system;
  - 1.3.3. the inclusion or elimination of components capable of altering the optical effects by reflection, refraction, absorption and/or deformation during operation. However, the fitting or elimination of filters designed solely to change the colour of the beam and not its light distribution shall not constitute a change in the type;
  - 1.3.4. suitability for right-hand or left-hand traffic or for both traffic systems;
  - 1.3.5. the kind of beam produced (passing beam, driving beam or both;)
  - 1.3.6. the holder intended to accommodate the filament lamp (or lamps) of one of the categories H<sub>1</sub>, H<sub>2</sub>, H<sub>3</sub>, HB<sub>3</sub>, HB<sub>4</sub>, H<sub>7</sub>, H<sub>8</sub>, H<sub>9</sub>, HIR1 and/or HIR2;<sup>2/\*/</sup>
  - 1.3.7. the materials constituting the lenses and coating, if any.

### 2. APPLICATION FOR APPROVAL OF A HEADLAMP <sup>3/</sup>

- 2.1. The application for approval of a headlamp shall be submitted by the owner of the trade name or mark or by his duly accredited representative. It shall specify:
  - 2.1.1. whether the headlamp is intended to provide both a passing beam and driving beam or only one of these beams;
  - 2.1.2. whether, if the headlamp is intended to provide a passing beam, it is designed for both left-hand and right-hand traffic or for either left-hand or right-hand traffic only;

---

<sup>1/</sup> Nothing in this Regulation shall prevent a Party to the Agreement applying this Regulation from prohibiting the combination of a headlamp incorporating a lens of plastic material approved under this Regulation with a mechanical headlamp-cleaning device (with wipers).

<sup>2/</sup> Type of lamp ("lamp type") should not be confused with "category of lamp" ("lamp category"). This Regulation concerns headlamps using halogen filament lamps of categories H<sub>1</sub>, H<sub>2</sub>, H<sub>3</sub>, HB<sub>3</sub>, HB<sub>4</sub>, H<sub>7</sub>, H<sub>8</sub>, H<sub>9</sub>, HIR1 and/ or HIR2. These categories of filament lamps differ essentially in their design and, more particularly, in the cap. They are not interchangeable, but within one filament lamp category there may normally be several types.

<sup>\*/</sup> HIR1, HIR2, and H<sub>9</sub> lamps will not be used to produce passing beam as long as there was no general agreement on the use of levelling devices and headlamp cleaners with respect to the level of the luminous flux.

<sup>3/</sup> Application for approval of a filament lamp: see Regulation No. 37.

- 2.1.2.1. if the headlamp is equipped with an adjustable reflector, the mounting position(s) of the headlamp in relation to the ground and the longitudinal median plane of the vehicle;
  - 2.1.3. the colour of the beam emitted by the headlamp.
  - 2.2. Every application shall be accompanied by:
    - 2.2.1. drawings in triplicate in sufficient detail to permit identification of the type and representing a frontal view of the headlamp, with details of lens ribbing if any, and the cross-section; the drawings shall indicate the space reserved for the approval mark;
      - 2.2.1.1. if the headlamp is equipped with an adjustable reflector, an indication of the mounting position(s) of the headlamp in relation to the ground and the longitudinal median plane of the vehicle, if the headlamp is for use in that (those) position(s) only;
    - 2.2.2. In any test of conformity carried out by the manufacturer, equivalent methods may be used with the consent of the competent authority responsible for approval tests. The manufacturer is responsible for proving that the applied methods are equivalent to those laid down in this Regulation.
    - 2.2.3. two samples of the type of headlamp;
    - 2.2.4. for the test of plastic material of which the lenses are made:
      - 2.2.4.1. thirteen lenses:
        - 2.2.4.1.1. six of these lenses may be replaced by six samples of material at least 60 x 80mm in size, having a flat or convex outer surface and a substantially flat area (radius of curvature not less than 300mm) in the middle measuring at least 15 x 15mm;
        - 2.2.4.1.2. every such lens or sample of material shall be produced by the method to be used in mass production;
      - 2.2.4.2. a reflector to which the lenses can be fitted in accordance with the manufacturer's instructions.
  - 2.3. The materials making up the lenses and coatings, if any, shall be accompanied by the test report of the characteristics of these materials and coatings if they have already been tested.
  - 2.4. The component authority shall verify the existence of satisfactory arrangements for ensuring effective control of the conformity of production before type approval is granted.
- 3. MARKINGS**<sup>4/</sup>
- 3.1. Headlamps submitted for approval shall bear the trade name or mark of the applicant.

---

<sup>4/</sup> In the case of headlamps designed to meet the requirements of traffic moving on one side of the road only (either right or left), it is further recommended that the area which can be occulted to prevent discomfort to users in a country where traffic moves on the side of the road opposite to that of the country for which the headlamp was designed should be outlined indelibly on the front lens. This marking is not necessary, however, where the area is clearly apparent from the design.

- 3.2. They shall comprise, on the lens and on the main body,<sup>5/</sup> spaces of sufficient size for the approval mark and the additional symbols referred to in paragraph 4; these spaces shall be indicated on the drawings referred to in paragraph 2.2.1. above.
- 3.3. Headlamps designed to satisfy the requirements of both right-hand and left-hand traffic shall bear markings indicating the two settings of the optical unit of the vehicle or of the filament lamp on the reflector; these markings shall consist of the letters "R/D" for the position for right-hand traffic and the letters "L/G" for the position for left-hand traffic.

#### **4. APPROVAL**

##### **4.1. General**

- 4.1.1. If all the samples of a type of headlamp submitted in pursuance of paragraph 2 above meet the requirements of this Regulation, approval shall be granted.
- 4.1.2. Where grouped, combined or reciprocally incorporated lamps satisfy the requirements of more than one Regulation, a single international approval mark may be affixed provided that each of the grouped, combined or reciprocally incorporated lamps satisfies the provisions applicable to it.
- This requirement shall not apply to headlamps fitted with a two-filament bulb when a single beam is approved.
- 4.1.3. An approval number shall be assigned to each type approved. Its first two digits (at present 04) shall indicate the series of amendments incorporating the most recent major technical amendments made to the Regulation at the time of issue of the approval. The same Contracting Party shall not assign the same number to another type of headlamp covered by this Regulation, except if the approval is extended to a device which only differs from the already approved device by the colour of the light emitted.
- 4.1.4. Notice of approval or of extension or refusal or withdrawal of approval or production definitely discontinued of a type of headlamp pursuant to this Regulation shall be communicated to the Parties to the 1958 Agreement applying this Regulation by means of a form conforming to the model in Annex 1 to this Regulation, with the indications according to paragraph 2.2.1.1.
- 4.1.4.1. If the headlamp is equipped with an adjustable reflector and if this headlamp is to be used only in mounting positions according to the indications in paragraph 2.2.1.1., the applicant shall be obliged by the approval to inform the user in a proper way about the correct mounting position(s).
- 4.1.5. In addition to the mark prescribed in paragraph 3.1., an approval mark as described in paragraph 4.2. and 4.3. below shall be affixed in the spaces referred to in paragraph 3.2. above to every headlamp conforming to a type approved under this Regulation.

##### **4.2. Composition of the approval mark**

The approval mark shall consist of:

- 4.2.1. an international approval mark, comprising:

---

<sup>5/</sup> If the lens cannot be detached from the main body of the headlamp, a space on the lens shall be sufficient.

- 4.2.1.1. a circle surrounding the letter 'E' followed by the distinguishing number of the country which has granted approval;<sup>6/</sup>
- 4.2.1.2. the approval number prescribed in paragraph 4.1.3. above.
- 4.2.2. The following additional symbol or symbols:
  - 4.2.2.1. on headlamps meeting left-hand traffic requirements only, a horizontal arrow pointing to the right of an observer facing the headlamp, i.e. to the side of the road on which traffic moves;
  - 4.2.2.2. on headlamps designed to meet the requirements of both traffic systems by means of an appropriate adjustment of the setting of the optical unit or the filament lamp, a horizontal arrow with a head at each end, the heads pointing respectively to the left and to the right;
  - 4.2.2.3. on headlamps meeting the requirements of this Regulation in respect of the passing beam only, the letters "HC";
  - 4.2.2.4. on headlamps meeting the requirements of this Regulation in respect of the driving beam only, the letters "HR";
  - 4.2.2.5. on headlamps meeting the requirements of this Regulation in respect of both the passing beam and the driving beam, the letters "HCR";
  - 4.2.2.6. on headlamps incorporating a lens of plastic material, the group of letters "PL" to be affixed near the symbols prescribed in paragraphs 4.2.2.3. to 4.2.2.5. above;
  - 4.2.2.7. on headlamps meeting the requirements of this Regulation in respect of the driving beam, an indication of the maximum luminous intensity expressed by a reference mark as defined in paragraph 6.3.2.1.2. below, placed near the circle surrounding the letter 'E'; in the case of reciprocally incorporated headlamps, indication of the maximum luminous intensity of the driving beams as a whole shall be expressed as above.
- 4.2.3. In every case the relevant operating mode used during the test procedure according to paragraph 1.1.1.1. of Annex 5 and the allowed voltage(s) according to paragraph 1.1.1.2. of Annex 5 shall be stipulated on the approval certificate and on the communication form transmitted to the countries which are Contracting Parties to the Agreement and which apply this Regulation. In the corresponding cases, the device shall be marked as follows:
  - 4.2.3.1. on headlamps meeting the requirements of this Regulation which are so designed that the filament of the passing beam shall not be lit simultaneously with that of any other lighting function with which it may be reciprocally incorporated, an

---

<sup>6/</sup> 1 for Germany, 2 for France, 3 for Italy, 4 for the Netherlands, 5 for Sweden, 6 for Belgium, 7 for Hungary, 8 for the Czech Republic, 9 for Spain, 10 for Yugoslavia, 11 for the United Kingdom, 12 for Austria, 13 for Luxembourg, 14 for Switzerland, 15 (vacant), 16 for Norway, 17 for Finland, 18 for Denmark, 19 for Romania, 20 for Poland, 21 for Portugal and 22 for the Russian Federation, 23 for Greece, 24 (vacant), 25 for Croatia, 26 for Slovenia, 27 for Slovakia, 28 for Belarus, 29 for Estonia, 30 (vacant), 31 for Bosnia and Herzegovina, 32-36 (vacant), 37 for Turkey, 38-39 (vacant) and 40 for The former Yugoslav Republic of Macedonia. Subsequent numbers shall be assigned to other countries in the chronological order in which they ratify or accede to the Agreement Concerning the Adoption of Uniform Technical Prescriptions for Wheeled Vehicles and the Conditions for Reciprocal Recognition of Approvals Granted on the Basis of these Prescriptions, and the numbers thus assigned shall be communicated by the Secretary-General of the United Nations to the Contracting Parties to the Agreement.

oblique stroke (/) shall be placed behind the passing lamp symbol in the approval mark.

4.2.3.2. on headlamps meeting the requirements of Annex 5 to this Regulation only when supplied with a voltage of 6V or 12V, a symbol consisting of the number 24 crossed out by an oblique cross (X) shall be placed near the filament lamp holder.

4.2.4. The two digits of the approval number (at present 04) which indicate the series of amendments incorporating the most recent major technical amendments made to the Regulation at the time of issue of the approval and, if necessary, the required arrow may be marked close to the above additional symbols.

4.2.5. The marks and symbols referred to in paragraphs 4.2.1. and 4.2.2. shall be clear legible and indelible even when the headlamp is mounted on the vehicle.

#### 4.3. Arrangement of the approval mark

##### 4.3.1. Independent lamps

Annex 3, Figures 1 to 9, gives examples of arrangements of the approval marks with the above-mentioned additional symbols.

##### 4.3.2. Grouped, combined or reciprocally incorporated lamps

4.3.2.1. Where grouped, combined or reciprocally incorporated lamps have been found to comply with the requirements of several Regulations, a single international approval mark may be affixed, consisting of a circle surrounding the letter "E", followed by the distinguishing number of the country which has granted the approval and an approval number. This approval mark may be located anywhere on the grouped, combined or reciprocally incorporated lamps, provided that:

4.3.2.1.1. it is visible after their installation,

4.3.2.1.2. no part of the grouped, combined or reciprocally incorporated lamps that transmits light can be removed without at the same time removing the approval mark.

4.3.2.2. The identification symbol for each lamp appropriate to each Regulation under which approval has been granted, together with the corresponding series of amendments incorporating the most recent major technical amendments to the Regulations at the time of issue of the approval and, if necessary, the required arrow shall be marked:

either

4.3.2.2.1. on the appropriate light-emitting surface,

or

4.3.2.2.2. in a group, in such a way that each of the grouped, combined or reciprocally incorporated lamps may be clearly identified (see four examples shown in Annex 3).

4.3.2.3. The size of the components of a single approval mark shall not be less than the minimum size required for the smallest of the individual marks under which approval has been granted.

4.3.2.4. An approval number shall be assigned to each type approved. The same Contracting Party may not assign the same number to another type of grouped, combined or reciprocally incorporated lamps covered by this Regulation.

4.3.2.5. Annex 3, Figure 10, of this Regulation gives examples of arrangements of approval marks for grouped, combined or reciprocally incorporated lamps with all the above- mentioned additional symbols.

4.3.3. Lamps, the lens of which is used for different types of headlamps and which may be reciprocally incorporated or grouped with other lamps

The provisions laid down in paragraph 4.3.2. above are applicable.

4.3.3.1. In addition where the same lens is used, the latter may bear the different approval marks relating to the different types of headlamps or units of lamps, provided that the main body of the headlamp, even if it cannot be separated from the lens, also comprises the space described in paragraph 3.2. above and bears the approval marks of the actual functions.

If different types of headlamps comprise the same main body, the latter may bear the different approval marks.

4.3.3.2. Annex 3, Figure 11, of this Regulation gives examples of arrangements of approval marks corresponding to that case.

## **B. TECHNICAL REQUIREMENTS FOR HEADLAMPS <sup>7/</sup>**

### **5. GENERAL SPECIFICATIONS**

5.1. Each sample shall conform to the specifications set forth in paragraphs 6 to 8 below.

5.2. Headlamps shall be so made as to retain their prescribed photometric characteristics and to remain in good working order when in normal use, in spite of the vibrations to which they may be subjected.

5.2.1. Headlamps shall be fitted with a device enabling them to be so adjusted on the vehicle as to comply with the rules applicable to them. Such a device need not be fitted on components in which the reflector and the lens cannot be separated provided the use of such components is confined to vehicles on which the headlamp setting can be adjusted by other means. Where a headlamp providing a driving beam and a headlamp providing a passing beam, each equipped with its own filament lamp, are assembled to form a composite unit, the adjusting device shall enable each optical system individually to be duly adjusted. However, this shall not apply to headlamp assemblies whose reflectors are indivisible. For this type of assembly, the requirements of paragraph 6 shall apply.

---

<sup>7/</sup> Technical requirements for filament lamps: see Regulation No. 37.

- 5.3. The components by which the filament lamp(s) is/are fixed to the reflector shall be so made that, even in darkness, the filament lamp(s) can be fixed in no other position but the correct one.<sup>8/</sup>

The filament lamp-holder shall conform to the dimensional characteristics as given in the following data sheets of IEC Publication 61-2:

Filament lamps	Holder	Data Sheets
H	P14.5s	7005-46-3
H <sub>2</sub>	X5111	7005-99-2
H <sub>3</sub>	PK22s	7005-47-1
HB <sub>3</sub>	P20d	7005-31-1
HB <sub>4</sub>	P22d	7005-32-1
H <sub>7</sub>	PX26d	7005-5-1
H <sub>8</sub>	PG17	7005-110-1
HIR1	PX20d	7005- ... -1
HIR2	PX22d	7005- ... -
H <sub>9</sub>	PGJ19-5	7005-110-1

- 5.4. Headlamps designed to satisfy the requirements of both right-hand and left-hand traffic may be adapted for traffic on a given side of the road either by an appropriate initial setting when fitted on the vehicle or by selective setting by the user. Such initial or selective setting may consist, for example, of fixing either the optical unit at a given angle on the vehicle or the filament lamp at a given angle in relation to the optical unit. In all cases, only two precise setting positions, one for right-hand and one for left-hand traffic, shall be possible, and the design shall preclude inadvertently shifting of the headlamp from one position to the other or its setting in an intermediate position. Where two different setting positions are provided for the filament lamp, the components attaching the filament lamp to the reflector must be so designed and made that, in each of its two settings, the filament lamp will be held in position with the precision required for headlamps intended for traffic on only one side of the road. Conformity with the requirements of this paragraph shall be verified visually and, where necessary, by a test fitting.
- 5.5. On headlamps designed to provide alternately a driving beam and a passing beam, any mechanical, electromechanical or other device incorporated in the headlamp for switching from one beam to the other<sup>9/</sup> must be so constructed that:
- 5.5.1. the device is strong enough to be worked 50,000 times without suffering damage despite the vibration to which it may be subjected in normal use;
  - 5.5.2. in the case of failure it is possible to obtain the passing beam automatically;
  - 5.5.3. either the passing beam or the driving beam can always be obtained without any possibility of the mechanism stopping in between the two positions;
  - 5.5.4. the user cannot, with ordinary tools, change the shape or position of the moving parts.

<sup>8/</sup> A headlamp is regarded as satisfying the requirements of this paragraph if the filament lamp can easily be fitted into the headlamp and the positioning lugs can be correctly fitted into their slots even in darkness.

<sup>9/</sup> These provisions shall not apply to the control switch.

- 5.6. Complementary tests shall be done according to the requirements of Annex 5 to ensure that in use there is no excessive change in photometric performance.
- 5.7. If the lens of the headlamp is of plastic material, tests shall be done according to the requirements of Annex 6.

**6. ILLUMINATION**

**6.1. General provisions**

- 6.1.1. Headlamps shall be so made that with suitable H<sub>1</sub>, H<sub>2</sub>, H<sub>3</sub>, HB<sub>3</sub>, HB<sub>4</sub>, H<sub>7</sub>, H<sub>8</sub>, H<sub>9</sub>, HIR1 and/or HIR2 filament lamps they provide adequate illumination without dazzle in the case of the passing beam and good illumination in the case of the driving beam.
- 6.1.2. The illumination produced by the headlamp shall be checked on a vertical screen set at a distance of 25m in front of the headlamp and at right angles to its axis (see Annex 4).
- 6.1.3. The headlamps shall be checked by means of (a) standard (reference) filament lamp(s) designed for a rated voltage of 12V, any selective-yellow filters<sup>10/</sup> being replaced by geometrically identical uncoloured filters with a transmission factor of at least 80%. During the checking of the headlamp the voltage at the terminals of the filament lamp must be regulated so as to obtain the following characteristics:

Filament lamps	Approximate supply voltage (in V) for measurement	Light flux (in lumens)
H	12	1,150
H <sub>2</sub>	12	1,300
H <sub>3</sub>	12	1,100
HB <sub>3</sub>	12	1,300
HB <sub>4</sub>	12	825
H <sub>7</sub>	12	1,100
H <sub>8</sub>	12	600
HIR1	12	1,840
HIR2	12	1,355
H <sub>9</sub>	12	1,500

The headlamp shall be deemed satisfactory if the photometric requirements are met with at least one standard (reference) 12V filament lamp which may be supplied with the headlamp.

- 6.1.4. The dimensions determining the position of the filament inside the standard filament lamp are shown on the relevant data sheet of Regulation No. 37.
- 6.1.5. The bulb of the standard filament lamp must be of such optical shape and quality that it does not cause any reflection or refraction adversely affecting the light distribution. Compliance with this requirement must be checked by measuring the light distribution obtained when a standard headlamp is fitted with the standard (reference) filament lamp.

**6.2. Provisions regarding passing beams**

<sup>10/</sup> These filters shall consist of all the components, including the lens, which are intended to colour the light.

- 6.2.1. The passing beam must produce a sufficiently sharp "cut-off" to permit satisfactory adjustment with its aid. The "cut-off" must be a horizontal straight line on the side opposite to the direction of traffic for which the headlamp is intended; on the other side it must extend neither beyond the broken line HV H<sub>1</sub> H<sub>4</sub> formed by a straight line HV H<sub>1</sub> standing at an angle of 45 degrees to the horizontal and a straight line H<sub>1</sub> H<sub>4</sub> lying 25cm above the straight line hh, nor beyond the straight line HV H<sub>3</sub>, inclined at an angle of 15 degrees above the horizontal (see Annex 4). A "cut-off" extending beyond both line HV H<sub>2</sub> and line H<sub>2</sub> H<sub>4</sub> and resulting from a combination of the above two possibilities shall in no circumstances be permitted.
- 6.2.2. The headlamp shall be so aimed that:
- 6.2.2.1. in the case of headlamps designed to meet the requirements of right-hand traffic, the "cut-off" on the left half of the screen<sup>11/</sup> is horizontal and, in the case of headlamps designed to meet the requirements of left-hand traffic, the "cut-off" on the right half of the screen is horizontal;
- 6.2.2.2. this horizontal part of the "cut-off" is situated on the screen 25cm below the line hh (see Annex 4);
- 6.2.2.3. the "elbow" of the "cut-off" is on line vv.<sup>12/</sup>
- 6.2.3. When so aimed, the headlamp need, if its approval is sought solely for a passing beam,<sup>13/</sup> comply only with the requirements referred to in paragraphs 6.2.5. to 6.2.7. below; if it is intended to provide both a passing beam and a driving beam it shall comply with the requirements referred to in paragraphs 6.2.5. to 6.2.7. and 6.3.
- 6.2.4. Where a headlamp so aimed does not meet the requirements referred to in paragraphs 6.2.5. to 6.2.7. and 6.3., its alignment may be changed, provided that the axis of the beam is not laterally displaced by more than 1 degree (=44cm) to the right or left.<sup>14/</sup> To facilitate alignment by means of the "cut-off", the headlamp may be partially occulted in order to sharpen the "cut-off".

---

<sup>11/</sup> The test screen must be sufficiently wide to allow examination of the "cut-off" of at least 5 degrees each side of the line vv.

<sup>12/</sup> If, in the case of a headlamp designed to satisfy the requirements of this Regulation with respect to the passing beam only, the focal axis diverges appreciably from the general direction of the beam, or if, whatever the type of headlamp (passing only or combined passing and driving), the beam does not have a "cut-off" with a clear "elbow", the lateral adjustment shall be affected in the manner which best satisfies the requirements for illumination at points 75R and 50R for right-hand traffic and at points 75L and 50L for left-hand traffic.

<sup>13/</sup> A headlamp designed to emit a passing beam may incorporate a driving beam not complying with this specification.

<sup>14/</sup> The limit or re-alignment of 1 degree towards the right or left is not incompatible with upward or downward vertical realignment. The latter is limited only by the requirements of paragraph 6.3.; however, the horizontal part of the "cut-off" should not extend beyond the line hh (the provisions of paragraph 6.3. are not applicable to headlamps intended to meet the requirements of this Regulation for the passing beam only).

6.2.5. The illumination produced on the screen by the passing beam shall meet the following requirements:

**Point on Measuring Screen**

Headlamp for right-hand traffic		Headlamp for left-hand traffic		Required illumination in lux
Point B	50 L	Point B	50 R	< 0.4
“ 75	R	“ 75	L	> 12
“ 75	L	“ 75	R	< 12
“ 50	L	“ 50	R	< 15
“ 50	R	“ 50	L	> 12
“ 50	V	“ 50	V	> 6
“ 25	L	“ 25	R	> 2
“ 25	R	“ 25	L	> 2
Any point in zone III				< 0.7
Any point in zone IV				> 3
Any point in zone I				< 2 x (E <sub>50R</sub> or E <sub>50L</sub> )*

6.2.6. There shall be no lateral variations detrimental to good visibility in any of the zones I, II, III, and IV.

6.2.7. The illumination values in zones "A" and "B" as shown in Figure C in Annex 4 shall be checked by the measurement of the photometric values of points 1 to 8 on this Figure; these values shall lie within the following limits:

1+2+3 > 0.3 lux, and

4+5+6 > 0.6 lux, and

0.7 lux > 7 > 0.1 lux and

0.7 lux > 8 > 0.2 lux <sup>\*/</sup>

These new values shall not be required for headlamps which have been approved before the application date of Supplement 4 to the 04 series of amendments to this Regulation (13 January 1993) nor to the extensions of such approvals.

6.2.8. Headlamps designed to meet the requirements of both right-hand and left-hand traffic must, in each of the two setting positions of the optical unit or of the filament lamp, meet the requirements set forth above for the corresponding direction of traffic.

**6.3. Provisions regarding driving beams**

6.3.1. In case of a headlamp designed to provide a driving beam and a passing beam, measurements of the illumination produced on the screen by the driving beam shall be taken with the same headlamp alignment as for measurements under paragraphs 6.2.5. to 6.2.7. above; in the case of a headlamp providing a driving beam only, it shall be so adjusted that the area of maximum illumination is centred on the point of intersection of the lines hh and vv; such a headlamp need meet only the requirements referred to in paragraph 6.3.

\* E<sub>50R</sub> and E<sub>50L</sub> are the illuminations actually measured.

<sup>\*/</sup> Illumination values in any point of zones A and B, which also lies within zone III, shall not exceed 0.7lux.

- 6.3.2. The illumination produced on the screen by the driving beam shall meet the following requirements:
- 6.3.2.1. the point of intersection (HV) of the lines hh and vv shall be situated within the isolux representing 80% of maximum illumination. This maximum value ( $E_M$ ) shall be not less than 48lux. The maximum value shall in no case exceed 240 lux; moreover, in the case of a combined passing and driving headlamp, this maximum value shall not be more than 16 times the illumination measured for the passing beam at point 75R (or 75L).

- 6.3.2.1.1. The maximum luminous intensity ( $I_M$ ) of the driving beam expressed in thousands of candelas shall be calculated by means of the formula:

$$I_M = 0.625 E_M$$

- 6.3.2.1.2. the reference mark ( $I_M$ ) indicating this maximum intensity and referred to in paragraph 4.2.2.7. above shall be obtained by means of the formula:

$$I'_M = \frac{I_M}{3} = 0.208 E_M$$

this value shall be rounded to whichever is the nearest of the following: 7.5., 10, 12.5, 17.5, 20, 25, 27.5, 30, 37.5, 40, 45, 50.

- 6.3.2.2. Starting from point HV, horizontally to the right and left the illumination shall be not less than 24 lux up to a distance of 1.125m and not less than 6 lux up to a distance of 2.25m.

- 6.4. In the case of headlamps with an adjustable reflector, the requirements of paragraphs 6.2. and 6.3. are applicable for each mounting position indicated according to paragraph 2.1.3. For verification, the following procedure shall be used:

- 6.4.1. each applied position is realized on the test goniometer with respect to a line joining the centre of the light source and point HV on the aiming screen. The adjustable reflector is then moved into such a position that the light pattern on the screen corresponds to the aiming prescriptions of paragraphs 6.2.1. to 6.2.2.3. and/or 6.3.1.;
- 6.4.2. with the reflector initially fixed according to paragraph 6.4.1., the headlamp must meet the relevant photometric requirements of paragraphs 6.2. and 6.3.;
- 6.4.3. additional tests are made after the reflector has been moved vertically +/- 2 degrees or at least into the maximum position, if less than 2 degrees, from its initial position by means of the headlamps adjusting device. Having re-aimed the headlamp as a whole (by means of the goniometer for example) in the corresponding opposite direction, the light output in the following directions shall be controlled and lie within the required limits:

passing beam:

points HV and 75R (75L respectively);

driving beam:

$I_M$  and point HV (percentage of  $I_M$ ).

- 6.4.4. If the applicant has indicated more than one mounting position, the procedure of paragraphs 6.4.1. to 6.4.3. shall be repeated for all the other positions;

- 6.4.5. if the applicant has not asked for special mounting positions, the headlamp shall be aimed for measurements of paragraphs 6.2. and 6.3. with the headlamps adjusting device in its mean position. The additional tests of paragraph 6.4.3. shall be made with the reflector moved into its extreme positions (instead of +/- 2 degrees) by means of the headlamps adjusting device.
- 6.5. The screen illumination values referred to in paragraphs 6.2.5. to 6.2.7. and 6.3. above shall be measured by means of a photoreceptor, the effective area of which shall be contained within a square of 65mm side.

## 7. REQUIREMENTS CONCERNING COLOURED LENSES AND FILTERS

- 7.1. Approval may be obtained for headlamps emitting either white or selective-yellow light with a filament lamp. Expressed in CIE trichromatic coordinates, the corresponding colorimetric characteristics are as follows:

Selective-yellow filter (screen or lens)

Limit towards red	$y > 0.138 + 0.580 x$
Limit towards green	$y < 1.29 x - 0.100$
Limit towards white	$y > -x + 0.966$
Limit towards spectral value	$y < -x + 0.992$

which can also be expressed as follows:

dominant wave-length:	575-585nm
purity factor:	0.90- 0.98

The transmission factor must be  $>0.78$  when determined by means of a source of light with a colour temperature of 2,856K.<sup>15/</sup>

- 7.2. The filter must be part of the headlamp, and must be attached to it in such a way that the user cannot remove it either inadvertently or, with ordinary tools, intentionally.

## 8. GAUGING DISCOMFORT

The discomfort caused by the passing beam of headlamps shall be gauged.<sup>16/</sup>

## 9. STANDARD HEADLAMP<sup>17/</sup>

A headlamp shall be deemed to be a standard (reference) headlamp if it:

- 9.1. satisfies the above-mentioned requirements for approval;
- 9.2. has an effective diameter of not less than 160mm;
- 9.3. provides with a standard filament lamp, at the various point and in the various zones referred to in paragraph 6.2.5., illumination equal to:
- 9.3.1. not more than 90% of the maximum limits and

<sup>15/</sup> Corresponding to illuminant A of the International Commission on Illumination (CIE).

<sup>16/</sup> This requirement will be the subject of a recommendation for the benefit of administrations.

<sup>17/</sup> Different values may be accepted provisionally. In the absence of final specifications, the use of an approved headlamp is recommended.

- 9.3.2. not less than 120% of the minimum limits prescribed in the table in paragraph 6.2.5.

## **10. OBSERVATION CONCERNING COLOUR**

Since any approval under this Regulation is granted, pursuant to paragraph 7.1. above, to a type of headlamp emitting either white light or selective-yellow light, article 3 of the Agreement to which the Regulation is annexed shall not prevent the Contracting Parties from prohibiting headlamps emitting a beam of white or selective-yellow light on vehicles registered by them.

## **C. FURTHER ADMINISTRATIVE PROVISIONS**

### **11. MODIFICATIONS AND EXTENSION OF APPROVAL OF A TYPE OF HEADLAMP**

- 11.1. Every modification of the headlamp type shall be notified to the administrative department which approved the type of headlamp. The department may then either:
- 11.1.1. consider that the modifications made are unlikely to have an appreciable adverse effect and that in any case the headlamp still complies with the requirements; or
- 11.1.2. require a further test report from the technical service responsible for conducting the tests.
- 11.2. Confirmation or refusal of approval, specifying the alterations, shall be communicated by the procedure specified in paragraph 4.1.4. above to the Parties to the Agreement applying this Regulation.
- 11.3. The competent authority issuing the extension of approval shall assign a series number for such an extension and inform thereof the other Parties to the 1958 Agreement applying this Regulation by means of a communication for conforming to the model in Annex 1 to this Regulation.

### **12. CONFORMITY OF PRODUCTION**

- 12.1. Headlamps approved under this Regulation shall be so manufactured as to conform to the type approved by meeting the requirements set forth in paragraphs 6 and 7.
- 12.2. In order to verify that the requirements of paragraph 12.1. are met, suitable controls of the production shall be carried out.
- 12.3. The holder of the approval shall in particular:
- 12.3.1. ensure the existence of procedures for the effective control of the quality of products;
- 12.3.2. have access to the control equipment necessary for checking the conformity to each approved type;
- 12.3.3. ensure that data of test results are recorded and that related documents shall remain available for a period to be determined in accordance with the administrative service;
- 12.3.4. analyze the results of each type of test in order to verify and ensure the stability of the product characteristics, making allowance for variation of an industrial production;

- 12.3.5. ensure that for each type of product at least the tests prescribed in Annex 2 to this Regulation are carried out;
- 12.3.6. ensure that any collecting of samples giving evidence of nonconformity with the type of test considered shall give rise to another sampling and another test. All the necessary steps shall be taken to re-establish the conformity of the corresponding production.
- 12.4. The competent authority which has granted type approval may at any time verify the conformity control methods applicable to each production unit.
- 12.4.1. In every inspection, the test books and production survey records shall be presented to the visiting inspector.
- 12.4.2. The inspector may take samples at random to be tested in the manufacturer's laboratory.  
The minimum number of samples may be determined in the light of the results of the manufacturer's own checks.
- 12.4.3. When the quality level appears unsatisfactory or when it seems necessary to verify the validity of the tests carried out in the application of paragraph 12.4.2. above, the inspector shall select samples, to be sent to the technical service which has conducted the type approval tests, using the criteria of Annex 7.
- 12.4.4. The competent authority may carry out any test prescribed in this Regulation. These tests will be on samples selected at random without causing distortion of the manufacturer's delivery commitments and in accordance with the criteria of Annex 7.
- 12.4.5. The competent authority shall strive to obtain a frequency of inspection of once every two years. However, this is at the discretion of the competent authority and their confidence in the arrangements for ensuring effective control of the conformity of production. In the case where negative results are recorded, the competent authority shall ensure that all necessary steps are taken to re-establish the conformity of production as rapidly as possible.
- 12.5. Headlamps with apparent defects are disregarded.
- 12.6. The reference mark is disregarded.

### **13. PENALTIES FOR NON-CONFORMITY OF PRODUCTION**

- 13.1. The approval granted in respect of a type of headlamp pursuant to this Regulation may be withdrawn if the requirements are not complied with or if a headlamp bearing the approval mark does not conform to the type approved.
- 13.2. If a Contracting Party to the Agreement applying this Regulation withdraws an approval it has previously granted, it shall forthwith so notify the other Contracting Parties applying this Regulation, by means of a communication form conforming to the model in Annex 1 to this Regulation.

### **14. PRODUCTION DEFINITELY DISCONTINUED**

If the holder of the approval completely ceases to manufacture a type of headlamp approved in accordance with this Regulation, he shall so inform the authority which granted the approval. Upon receiving the relevant communication, that authority shall inform thereof the other Parties to the 1958 Agreement applying

this Regulation by means of a communication form conforming to the model in Annex 1 to this Regulation.

**15. NAMES AND ADDRESSES OF TECHNICAL SERVICES RESPONSIBLE FOR CONDUCTING APPROVAL TESTS AND OF ADMINISTRATIVE DEPARTMENTS**

The Parties to the 1958 Agreement which apply this Regulation shall communicate to the United Nations Secretariat the names and addresses of the technical services responsible for conducting approval tests and of the administrative departments which grant approval and to which forms certifying approval or extension or refusal or withdrawal of approval, or production definitely discontinued, issued in other countries, are to be sent.

**Annex 1**

**COMMUNICATION**

**(maximum format: A4 (210 x 297))**

issued by: Name of Administration



concerning <sup>2/</sup> APPROVAL GRANTED  
APPROVAL EXTENDED  
APPROVAL REFUSED  
APPROVAL WITHDRAWN  
PRODUCTION DEFINITELY DISCONTINUED

of a type of headlamp pursuant to Regulation No.8.

Approval No.

Extension No.

1. Trade name or mark of headlamp:
2. Manufacturer's name for the type of headlamp:
3. Manufacturer's name and address:
4. If applicable, name and address of the manufacturer's representative
5. Submitted for approval on:
6. Technical Service responsible for conducting approval tests:
7. Date of report; issued by that service:
8. Number of report; issued by that service:
9. Brief description:  
Category as described by the relevant marking: <sup>3/</sup>  
Number and category(ies) of filament lamp or lamps

<sup>1/</sup> Distinguishing number of the country which as granted/extended/refused/withdrawn approval (see approval provisions in the Regulations).

<sup>2/</sup> Strike out what does not apply.

<sup>3/</sup> Indicate the appropriate marking selected from the list below:

HC, HC, HC, HR, HR PL, HCR, HCR, HCR, HC/R, HC/R, HC/R, HC/, HC/, HC/,  
→ ↔ → ↔ → ↔ → ↔  
HC PL, HC PL, HC PL, HCR PL, HCR PL, HCR PL, HC/R PL, HC/R PL, HC/R PL  
→ ↔ → ↔ → ↔ → ↔  
HC/PL, HC/PL, HC/PL  
→ ↔

- Colour of light emitted: white/selective/yellow:<sup>2/</sup>
10. Position of the approval mark:
  11. Reason(s) for extension (if applicable):
  12. Approval granted/extended/refused/withdrawn: <sup>2/</sup>
  13. Place:
  14. Date:
  15. Signature:
  16. The list of documents deposited with the Administrative Service which has granted approval is annexed to this communication and may be obtained on request.

## Annex 2

### VERIFICATION OF CONFORMITY OF PRODUCTION OF HEADLAMPS EQUIPPED WITH H<sub>1</sub>, H<sub>2</sub>, H<sub>3</sub> HB<sub>3</sub>, HB<sub>4</sub>, H<sub>7</sub>, H<sub>8</sub>, H<sub>9</sub>, HIR1 and/or HIR2 FILAMENT LAMPS

#### 1. GENERAL

- 1.1. The conformity requirements shall be considered satisfied from a mechanical and geometric standpoint, if the differences do not exceed inevitable manufacturing deviations within the requirements of this Regulation.
- 1.2. With respect to photometric performances, the conformity of mass produced headlamps shall not be contested if, when testing photometric performances of any headlamp chosen at random and equipped with a standard filament lamp:
- 1.2.1. no measured value deviates unfavourably by more than 20% from the values prescribed in this Regulation. For values B50L (or R) and zone III, the maximum unfavourable deviation may be respectively:
- |              |                       |
|--------------|-----------------------|
| B50L (or R): | 0.2lx equivalent 20%  |
|              | 0.3lx equivalent 30%  |
| Zone III:    | 0.3lx equivalent 20%  |
|              | 0.45lx equivalent 30% |
- 1.2.2. or if
- 1.2.2.1. for the passing beam, the values prescribed in this Regulation are met at HV (with a tolerance of + 0.2lx) and related to that aiming at least one point of each area delimited on the measuring screen (at 25m) by a circle 15cm in radius around points B50L (or R) <sup>1/</sup> (with a tolerance of + 0.1lx ), 75R (or L), 50V, 25R, 25L, and in the entire area of zone IV which is not more than 22.5cm above line 25R and 25L;
- 1.2.2.2. and if, for the driving beam, HV being situated within the isolux 0.75 E<sub>max</sub>, a tolerance of +20% for maximum values and -20% for minimum values is observed for the photometric values at any measuring point specified in paragraph 6.3.2. of this Regulation.
- 1.2.3. If the results of the tests described above do not meet the requirements, the alignment of the headlamp may be changed, provided that the axis of the beam is not displaced laterally by more than 1 degrees to the right or left. <sup>14/</sup>
- 1.2.4. If the results of the tests described above do not meet the requirements, tests on the headlamps shall be repeated using another standard filament lamp.
- 1.3. With respect to the verification of the change in vertical position of the cut-off line under the influence of heat, the following procedure shall be applied:
- One of the sampled headlamps shall be tested according to the procedure described in paragraph 2.1. of Annex 5 after being subjected three consecutive times to the cycle described in paragraph 2.2.2. of Annex 5.

<sup>1/</sup> Letters in brackets refer to headlamps intended for left-hand traffic.

<sup>14/</sup> See the corresponding footnote in the text of the Regulation.

The headlamp shall be considered as acceptable if  $\delta r$  does not exceed 1.5mrad.

If this value exceeds 1.5mrad but is not more than 2.0mrad, a second headlamp shall be subjected to the test after which the mean of the absolute values recorded on both samples shall not exceed 1.5mrad.

- 1.4. The chromaticity coordinates shall be complied with when the headlamp is equipped with a filament lamp set to Standard A colour temperature.

The photometric performance of a headlamp emitting selective yellow light when equipped with a colourless filament lamp shall be the values contained in this Regulation multiplied by 0.84.

## **2. MINIMUM REQUIREMENTS FOR VERIFICATION OF CONFORMITY BY THE MANUFACTURER**

For each type of headlamp the holder of the approval mark shall carry out at least the following tests, at appropriate intervals. The tests shall be carried out in accordance with the provisions of this Regulation.

If any sampling shows non-conformity with regard to the type of test concerned, further samples shall be taken and tested. The manufacturer shall take steps to ensure the conformity of the production concerned.

### **2.1. Nature of tests**

Tests of conformity in this Regulation shall cover the photometric characteristics and the verification of the change in vertical position of the cut-off line under the influence of heat.

### **2.2. Methods used in tests**

- 2.2.1. Tests shall generally be carried out in accordance with the methods set out in this Regulation.
- 2.2.2. In any test of conformity carried out by the manufacturer, equivalent methods may be used with the consent of the competent authority responsible for approval tests. The manufacturer is responsible for proving that the applied methods are equivalent to those laid down in this Regulation.
- 2.2.3. The application of paragraphs 2.2.1. and 2.2.2. requires regular calibration of test apparatus and its correlation with measurements made by a competent authority.
- 2.2.4. In all cases the reference methods shall be those of this Regulation, particularly for the purpose of administrative verification and sampling.

### **2.3. Nature of sampling**

Samples of headlamps shall be selected at random from the production of a uniform batch. A uniform batch means a set of headlamps of the same type, defined according to the production methods of the manufacturer.

The assessment shall in general cover series production from individual factories. However, a manufacturer may group together records concerning the same type from several factories, provided these operate under the same quality system and quality management.

2.4. Measured and recorded photometric characteristics

The sampled headlamp shall be subjected to photometric measurements at the points provided for in the Regulation, the reading being limited to points  $E_{\max}$ , HV<sup>1/</sup> HL, HR<sup>2/</sup> in the case of the driving beam, and to points B50L (or R), HV, 50V, 75R (or L) and 25L (or R) in the case of the passing beam (see Figure in Annex 4).

2.5. Criteria governing acceptability

The manufacturer is responsible for carrying out a statistical study of the test results and for defining, in agreement with the competent authority, criteria governing the acceptability of his products in order to meet the specifications laid down for verification of conformity of products in paragraph 12.1. of this Regulation.

The criteria governing the acceptability shall be such that, with a confidence level of 95%, the minimum probability of passing a spot check in accordance with Annex 7 (first sampling) would be 0.95.

---

<sup>1/</sup> When the driving beam is reciprocally incorporated with the passing beam, HV in the case of the driving beam shall be the same measuring point as in the case of the passing beam.

<sup>2/</sup> HL and HR: points on "hh" located at 1,125m to the left and to the right of point HV respectively.

Annex 3

EXAMPLES OF ARRANGEMENTS OF APPROVAL MARKS

1.

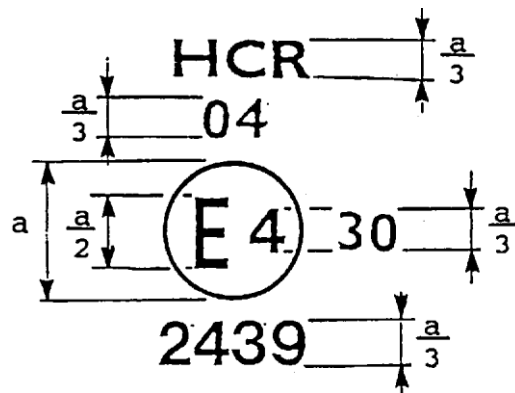

a = 12mm min.

Figure 1

The device bearing the approval mark shown above is a headlamp approved in the Netherlands (E4), under approval number 2439, meeting the requirements of this Regulation, as amended by the 04 series of amendments (04), in respect of both the passing beam and the driving beam (HCR) and is designed for right-hand traffic only. The number 30 indicates that the maximum luminous intensity of the driving beam is between 86,250 and 111,250 candelas.

Note:

The approval number and additional symbols must be placed close to the circle and either above or below the letter "E" or to left or right of that letter. The digits of the approval number must be on the same side of the "E" and face in the same direction. The use of Roman numerals as approval numbers should be avoided so as to prevent any confusion with other symbols.

2.

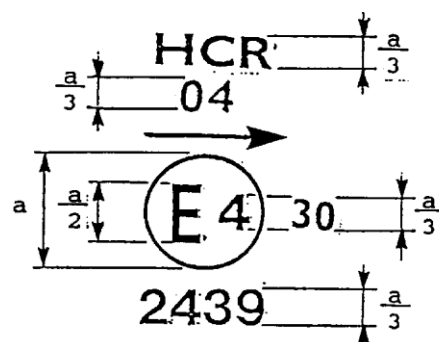

a = 12mm min

Figure 2

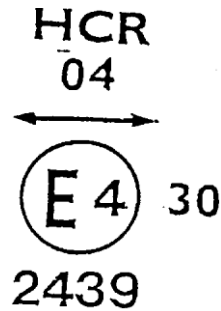

a = 12mm min.

Figure 3a



Figure 3b

The headlamp bearing the above approval mark meets the requirements of this Regulation in respect of both the passing beam and the driving beam and it designed: Figure 2 = For left-hand traffic only.

Figure 3a, 3b = For both traffic systems by means of an appropriate adjustment of the setting of the optical unit or the filament lamp on the vehicle.

3.

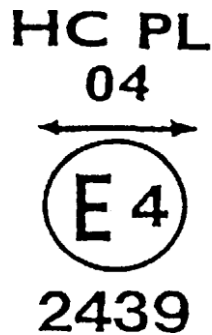

Figure 4

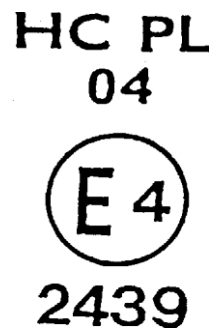

Figure 5

The headlamp bearing the above approval mark is a headlamp incorporating the lens of plastic material meeting the requirements of this Regulation in respect of the passing beam only and is designed:

Figure 4 = For both traffic systems

Figure 5 = For right-hand traffic only

4.

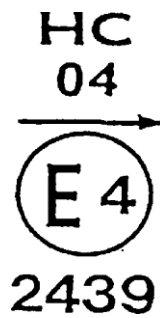

Figure 6

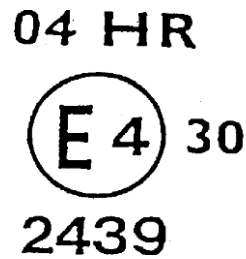

Figure 7

The headlamp bearing the above approval mark is a headlamp meeting the requirements of this Regulation:

Figure 6 = In respect of the passing beam only and is designed for left-hand traffic only. Figure 7 = In respect of the driving beam only.

5.

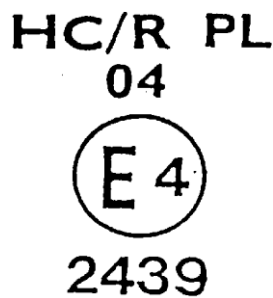

Figure 8

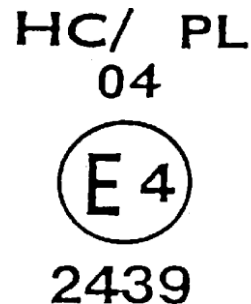

Figure 9

Identification of a headlamp incorporating the lens of plastic material meeting the requirements of Regulation No.8:

Figure 8 = With respect to both the passing beam and the driving beam and designed for right-hand traffic only.

Figure 9 = With respect to the passing beam only and designed for right-hand traffic only.

The passing lamp filament shall not be lit simultaneously with the driving lamp filament and/or another reciprocally incorporated headlamp.

**Simplified marking for grouped, combined or reciprocally incorporated lamps**

**Figure 10**

**(The vertical and horizontal lines schematize the shape of the light-signalling device. They are part of the approval mark.)**

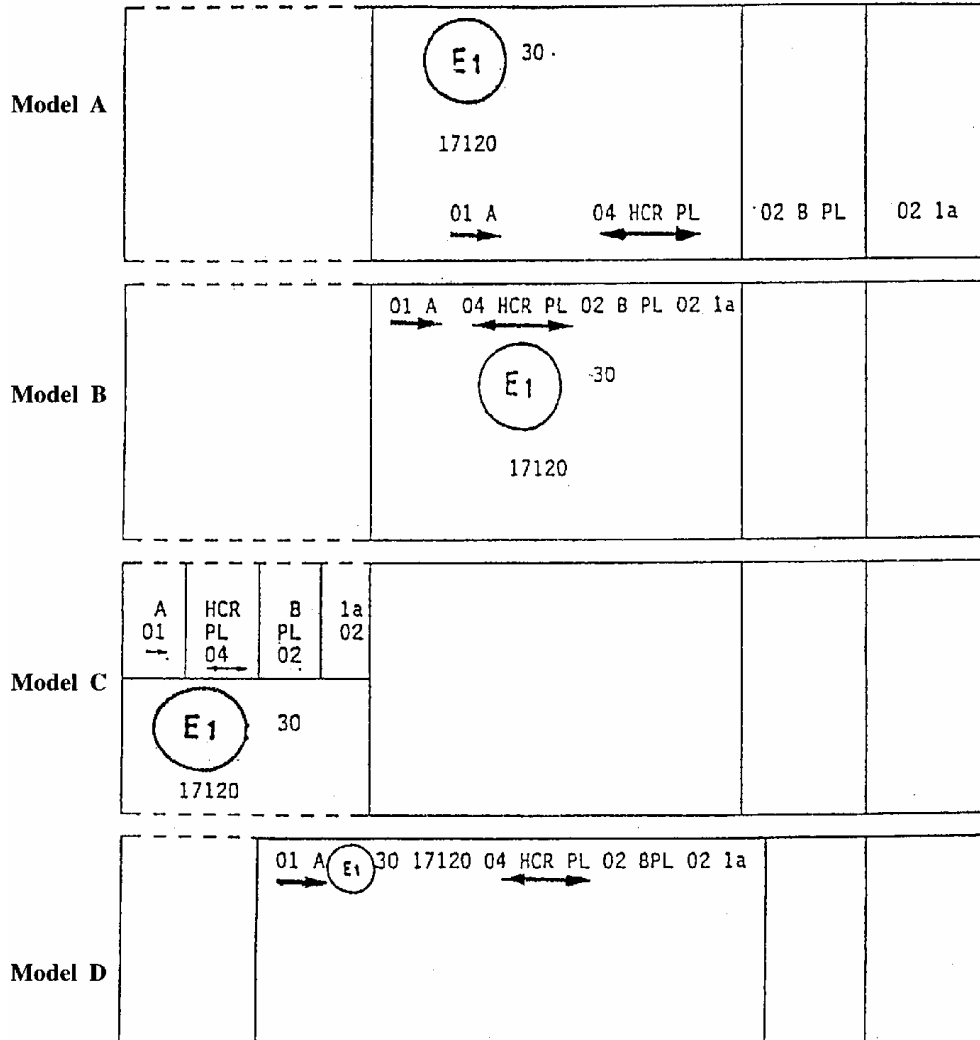

Note: The four examples above correspond to a lighting device bearing an approval mark comprising:

A front position lamp approved in accordance with the 01 series of amendments to Regulation No.7,

A headlamp with a passing beam designed for right- and left-hand traffic and a driving beam with a maximum intensity comprised between 86,250 and 111,250 candelas (as indicated by the number 30), approved in accordance with the 04 series of amendments to Regulation No. 8 and incorporating a lens of plastic material,

A front fog lamp approved in accordance with the 02 series of amendments to Regulation No. 19 and incorporating a lens of plastic material,

A front direction indicator lamp of category 1a approved in accordance with the 02 series of amendments to Regulation No. 6.

**Figure 11**

**Lamp reciprocally incorporated with a headlamp**

**Example 1**

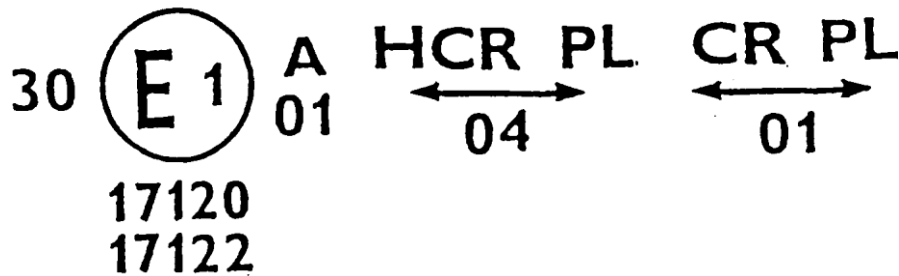

The above example corresponds to the marking of a lens of plastic material intended to be used in different types of headlamps, namely:

Either:

A headlamp with a passing beam designed for both traffic systems and a driving beam with a maximum luminous intensity comprised between 86,250 and 111,250 candelas (as indicated by the number 30), approved in Germany (E1) in accordance with the requirements of Regulation No. 8 as amended by the 04 series of amendments, which is reciprocally incorporated with

A front position lamp approved in accordance with the 01 series of amendments to Regulation No. 7;

Or

A headlamp with a passing beam designed for both traffic systems and a driving beam, approved in Germany (E1) in accordance with the requirements of Regulation No. 1 as amended by the 01 series of amendments, which is reciprocally incorporated with the same front position lamp as above;

Or

even either of the above-mentioned headlamps approved as a single lamp.

The main body of the headlamp shall bear the only valid approval number, for instance:

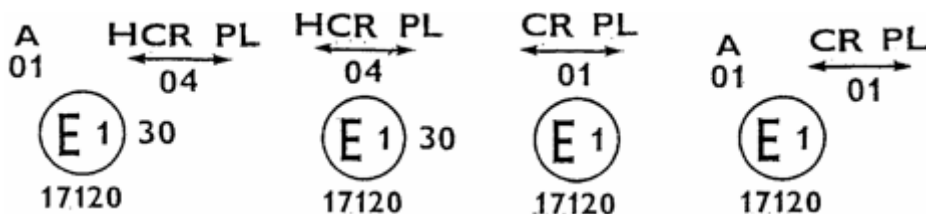





**B. Headlamp for left-hand traffic (dimensions in mm)**

STANDARD EUROPEAN BEAM

B. Headlamp for left-hand traffic  
 (dimensions in mm)

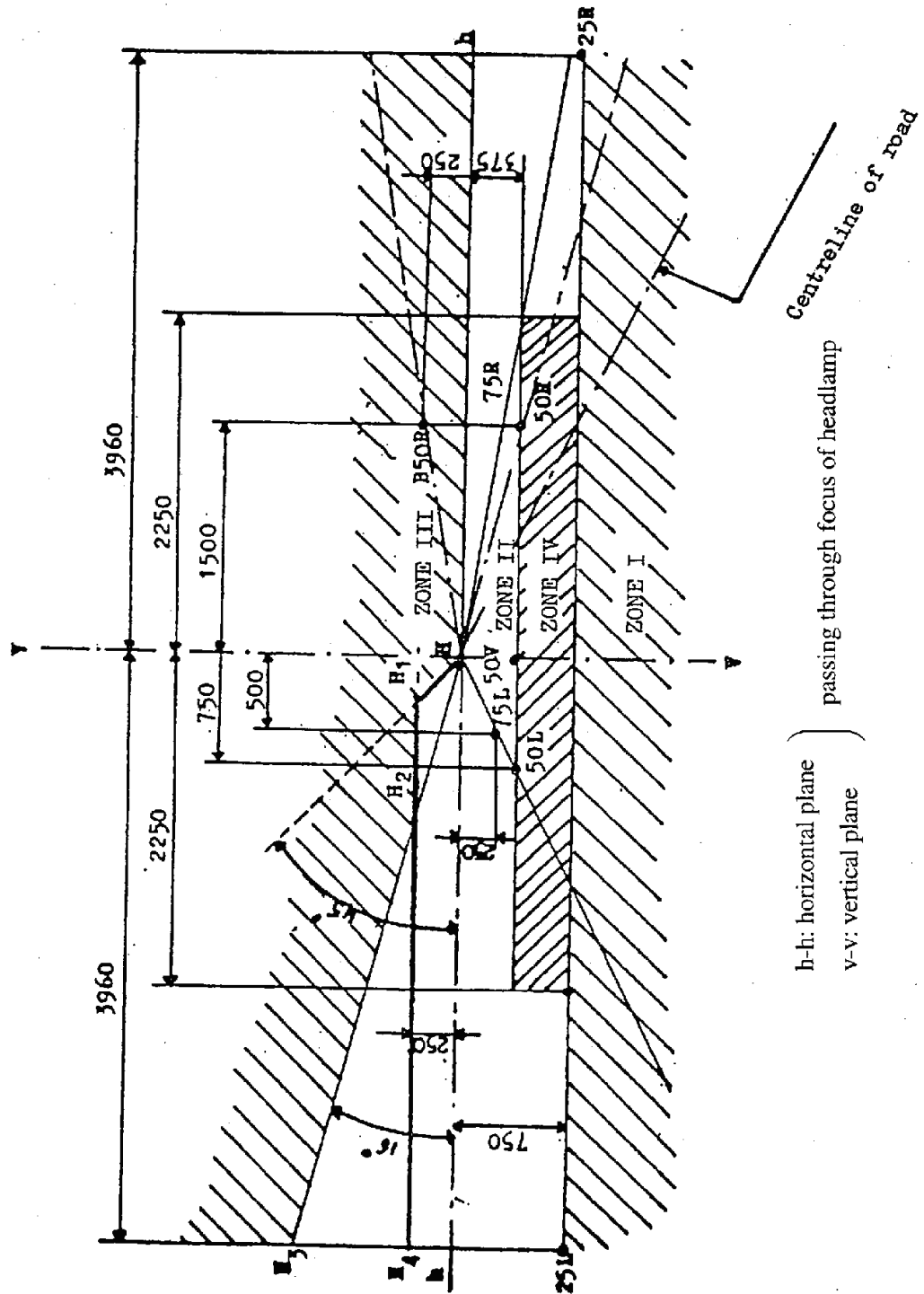

h-h: horizontal plane  
 v-v: vertical plane  
 passing through focus of headlamp

Centreline of road

**C. Measuring points for illumination values**

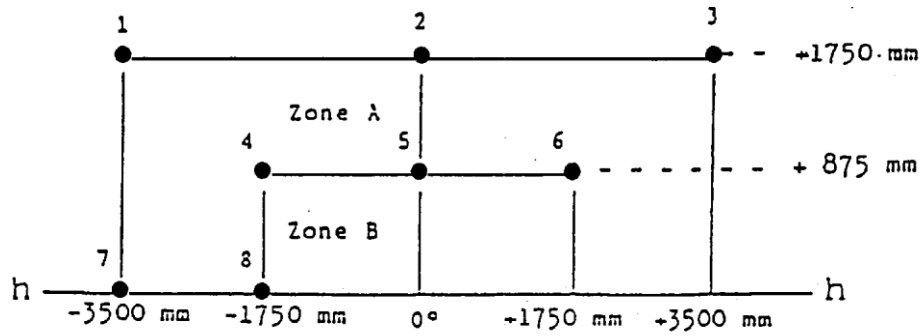

Note:

Figure C shows the measuring points for right-hand traffic.

Points 7 and 8 move to their corresponding location at the right-hand side of the picture for left-hand traffic.

## Annex 5

### TESTS FOR STABILITY OF PHOTOMETRIC PERFORMANCE OF HEADLAMPS IN OPERATION

#### TESTS ON COMPLETE HEADLAMPS

Once the photometric values have been measured according to the requirements of this Regulation in points for  $E_{\max}$  for driving beam and HV, 50R, B50L for passing beam (or HV, 50L, B50R for headlamps designed for left-hand traffic) a complete headlamp sample shall be tested for stability of photometric performance in operation. "Complete headlamp" shall be understood to mean the complete lamp itself, including those surrounding body parts and lamps which could influence its thermal dissipation.

#### 1. TEST OF STABILITY OF PHOTOMETRIC PERFORMANCE

The tests shall be carried out in a dry and still atmosphere at an ambient temperature of 23 degrees C +/- 5 degrees C, the complete headlamp being mounted on a base representing the correct installation on the vehicle.

##### 1.1. Clean headlamp

The headlamp shall be operated for 12 hours as described in subparagraph 1.1.1. and checked as prescribed in subparagraph 1.1.2.

##### 1.1.1. Test procedure

The headlamp shall be operated for a period according to the specified time, so that: 1.1.1.1.

- (a) in the case where only one lighting function (driving or passing beam) is to be approved, the corresponding filament is lit for the prescribed time, 1/
- (b) in the case of a reciprocally incorporated passing lamp and driving lamp (dual filament lamp or two filament lamps):

If the applicant declares that the headlamp is to be used with a single filament lit,<sup>2/</sup> the test shall be carried out in accordance with this condition, activating<sup>1/</sup> each specified function successively for half the time specified in paragraph 1.1,

In all other cases,<sup>1/ 2/</sup> the headlamp shall be subjected to the following cycle until the time specified is reached:

15 minutes, passing-beam filament lit

5 minutes, all filaments lit

- (c) in the case of grouped lighting functions, all the individual functions shall be lit simultaneously for the time specified for individual lighting functions (a) also taking into account the use of reciprocally incorporated lighting functions (b), according to the manufacturer's specifications.

---

<sup>1/</sup> When the tested headlamp is grouped and/or reciprocally incorporated with signalling lamps, the latter shall be lit for the duration of the test. In the case of a direction indicator lamp, it shall be lit in flashing operation mode with an on/off time ratio of approximately one to one.

<sup>2/</sup> Should two or more lamp filaments be simultaneously lit when headlamp flashing is used, this shall not be considered as being normal use of the filaments simultaneously.

1.1.1.2. Test voltage

The voltage shall be adjusted so as to supply 90% of the maximum wattage specified in the Regulation for filament lamps (Regulation No. 37). The applied wattage shall in all cases comply with the corresponding value of a filament lamp 12V rated voltage, except if the applicant for approval specifies that the headlamp may be used at a different voltage. In the latter case, the test shall be carried out with the filament lamp whose wattage is the highest that can be used.

1.1.2. Test results

1.1.2.1. Visual inspection

Once the headlamp has been stabilized to the ambient temperature, the headlamp lens and the external lens, if any, shall be cleaned with a clean, damp cotton cloth. It shall then be inspected visually, no distortion, deformation, cracking or change in colour of either the headlamp lens or the external lens, if any, shall be noticeable.

1.1.2.2. Photometric test

To comply with the requirements of this Regulation, the photometric values shall be verified in the following points:

Passing-beam:

50R - B50L - HV for headlamps designed for right-hand traffic,

50L - B50R - HV for headlamps designed for left-hand traffic.

Driving beam:

Point of  $E_{max}$

Another aiming may be carried out to allow for any deformation of the headlamp base due to heat (the change of the position of the cut-off line is covered in paragraph 2 of this Annex).

A 10% discrepancy between the photometric characteristics and the values measured prior to the test is permissible, including the tolerances of the photometric procedure.

1.2. Dirty headlamp

After being tested as specified in subparagraph 1.1. above, the headlamp shall be operated for one hour as described in subparagraph 1.1.1., after being prepared as prescribed in subparagraph 1.2.1., and checked as prescribed in subparagraph 1.1.2.

1.2.1. Preparation of the headlamp

1.2.1.1. Test mixture

1.2.1.1.1. For headlamp with the outside lens in glass:

The mixture of water and a polluting agent to be applied to the headlamp shall be composed of:

9 parts by weight of silica sand with a particle size of 0-100  $\mu m$ ,

1 part by weight of vegetal carbon dust (beechwood) with a particle size of 0-100  $\mu\text{m}$ , 0.2 parts by weight of NaCMC<sup>2/</sup>, and  
an appropriate quantity of distilled water, with a conductivity of <1mS/m.  
The mixture must not be more than 14 days old.

1.2.1.1.2. For headlamp with outside lens in plastic material:

The mixture of water and polluting agent to be applied to the headlamp shall be composed of:

9 parts by weight of silica sand with a particle size of 0-100  $\mu\text{m}$ ,  
1 part by weight of vegetal carbon dust (beechwood) with a particle size of 0-100  $\mu\text{m}$ , 0.2 part by weight of NaCMC<sup>2/</sup>,  
13 parts by weight of distilled water with a conductivity of <1mS/m, and  
2 +/- 1 parts by weight of surface-actant<sup>4/</sup>.  
The mixture must not be more than 14 days old.

1.2.1.2. Application of the test mixture to the headlamp

The test mixture shall be uniformly applied to the entire light emitting surface of the headlamp and then left to dry. This procedure shall be repeated until the illuminating value has dropped to 15-20% of the values measured for each following point under the conditions described in paragraph 1 above:

$E_{\text{max}}$  in driving beam for a driving/passing lamp,  
 $E_{\text{max}}$  in driving beam for a driving lamp only,  
50R and 50V<sup>5/</sup> for a passing lamp only, designed for right-hand traffic,  
50L and 50V<sup>5/</sup> for a passing lamp only, designed for left-hand traffic

1.2.1.3. Measuring equipment

The measuring equipment shall be equivalent to that used during headlamp approval tests. A standard (reference) filament lamp shall be used for the photometric verification.

**2. TEST FOR CHANGE IN VERTICAL POSITION OF THE CUT-OFF LINE UNDER THE INFLUENCE OF HEAT**

This test consists of verifying that the vertical drift of the cut-off line under the influence of heat does not exceed a specified value for an operating passing lamp.

The headlamp tested in accordance with paragraph 1 shall be subjected to the test described in paragraph 2.1. without being removed from or readjusted in relation to its test fixture.

---

<sup>2/</sup> NaCMC represents the sodium of carboxymethylcellulose, customarily referred to as CMC. The NaCMC used in the dirt mixture shall have a degree of substitution (DS) of 0.6-0.7 and viscosity of 200-300 cP for a 2% solution at 20 degrees C.

<sup>4/</sup> The tolerance on quantity is due to the necessity of obtaining a dirt that correctly spreads out on all the plastic lens.

<sup>5/</sup> 50 V is situated 375mm below HV on the vertical line v-v on the screen at 25m distance.

2.1. Test

The test shall be carried out in a dry and still atmosphere at an ambient temperature of 23 degrees C +/- 5 degrees C.

Using a mass production filament lamp which has been aged for at least one hour the headlamp shall be operated on passing beam without being dismantled from or readjusted in relation to its test fixture. (For the purpose of this test, the voltage shall be adjusted as specified in paragraph 1.1.1.2.) The position of the cut-off line in its horizontal part (between vv and the vertical line passing through point B50R for left-hand traffic or B50L for right-hand traffic) shall be verified 3 minutes ( $r_3$ ) and 60 minutes ( $r_{60}$ ) respectively after operation.

The measurement of the variation in the cut-off line position as described above shall be carried out by any method giving acceptable accuracy and reproducible results.

2.2. Test results

2.2.1. The result expressed in milliradians (mrad) shall be considered as acceptable when the absolute value  $\Delta r_1 + r_3 - r_{60}$  recorded on the headlamp is not more than 1.0mrad ( $\Delta r_1 < 1.0\text{mrad}$ ).

2.2.2. However, if this value is more than 1.0mrad but not more than 1.5mrad ( $1.0\text{mrad} < \Delta r_1 < 1.5\text{mrad}$ ), a second headlamp shall be tested as described in paragraph 2.1. after being subjected three consecutive times to the cycle as described below, in order to stabilize the position of mechanical parts of the headlamp on a base representative of the correct installation on the vehicle:

Operation of the passing lamp for one hour (the voltage shall be adjusted as specified in paragraph 1.1.1.2.).

Period of rest for one hour.

The headlamp type shall be considered as acceptable if the mean value of the absolute values  $\Delta r_1$  measured on the first sample and  $\Delta r_{11}$  measured on the second sample is not more than 1.0mrad.

$$\frac{\Delta r_1 + \Delta r_{11}}{2} \leq 1.0\text{mrad}$$

## Annex 6

### REQUIREMENTS FOR LAMPS INCORPORATING LENSES OF PLASTIC MATERIAL - TESTING OF LENS OR MATERIAL SAMPLES AND OF COMPLETE LAMPS

#### 1. GENERAL SPECIFICATIONS

- 1.1. The samples supplied pursuant to paragraph 2.2.4. of this Regulation shall satisfy the specifications indicated in paragraphs 2.1. to 2.5. below.
- 1.2. The two samples of complete lamps supplied pursuant to paragraph 2.2.3. of this Regulation and incorporating lenses of plastic material shall, with regard to the lens material, satisfy the specifications indicated in paragraph 2.6. below.
- 1.3. The samples of lenses of plastic material or samples of material shall be subjected, with the reflector to which they are intended to be fitted (where applicable), to approval tests in the chronological order indicated in Table A reproduced in Appendix 1 to this Annex.
- 1.4. However, if the lamp manufacturer can prove that the product has already passed the tests prescribed in paragraphs 2.1.-2.5. below, or the equivalent tests pursuant to another Regulation, those tests need not be repeated; only the tests prescribed in Appendix 1, Table B, shall be mandatory.

#### 2. TESTS

##### 2.1. Resistance to temperature changes

##### 2.1.1. Tests

Three new samples (lenses) shall be subjected to five cycles of temperature and humidity (RH = relative humidity) change in accordance with the following programme:

3 hours at 40 degrees C +/- 2 degrees C and 85-95% RH;

1 hour at 23 degrees C +/- 5 degrees C and 60-75% RH;

15 hours at -30 degrees C +/- 2 degrees C;

1 hour at 23 degrees C +/- 5 degrees C and 60-75% RH;

3 hours at 80 degrees C +/- 2 degrees C;

1 hour at 23 degrees C +/- 5 degrees C and 60-75% RH;

Before this test, the samples shall be kept at 23 degrees C +/- 5 degrees C and 60-75% RH for at least four hours.

Note:

The period of one hour at 23 degrees C +/- 5 degrees C shall include the periods of transition from one temperature to another which are needed in order to avoid thermal shock effects.

##### 2.1.2. Photometric measurements

##### 2.1.2.1. Method

Photometric measurements shall be carried out on the samples before and after the test. These measurements shall be made using a standard lamp, at the following points:

B 50L and 50R for the passing beam of a passing lamp or a passing/driving lamp (B 50R and 50L in the case of headlamps intended for left-hand traffic);

$E_{\max}$  route for the driving beam of a driving lamp or a passing/driving lamp;

#### 2.1.2.2. Results

The variation between the photometric values measured on each sample before and after the test shall not exceed 10% including the tolerances of the photometric procedure.

### 2.2. Resistance to atmospheric and chemical agents

#### 2.2.1. Resistance to atmospheric agents

Three new samples (lenses or samples of material) shall be exposed to radiation from a source having a spectral energy distribution similar to that of a black body at a temperature between 5,500K and 6,000K. Appropriate filters shall be placed between the source and the samples so as to reduce as far as possible radiations with wave lengths smaller than 295nm and greater than 2,500nm. The samples shall be exposed to an energetic illumination of 1,200W/m<sup>2</sup> +/- 200W/m<sup>2</sup> for a period such that the luminous energy that they receive is equal to 4,500MJ/m<sup>2</sup> +/- 200MJ/m<sup>2</sup>. Within the enclosure, the temperature measured on the black panel placed on a level with the samples shall be 50 degrees C +/- 5 degrees C. In order to ensure a regular exposure, the samples shall revolve around the source of radiation at a speed between 1 and 51/min.

The samples shall be sprayed with distilled water of conductivity lower than 1 mS/m at a temperature of 23 degrees C +/- 5 degrees C, in accordance with the following cycle:

spraying: 5 minutes;

drying: 25 minutes.

#### 2.2.2. Resistance to chemical agents

After the test described in paragraph 2.2.1. above and the measurement described in paragraph 2.2.3.1. below have been carried out, the outer face of the said three samples shall be treated as described in paragraph 2.2.2.2. with the mixture defined in paragraph 2.2.2.1. below.

##### 2.2.2.1. Test mixture

The test mixture shall be composed of 61.5% n-heptane, 12.5% toluene, 7.5% ethyl tetrachloride, 12.5% trichlorethylene and 6% xylene (volume %).

##### 2.2.2.2. Application of the test mixture

Soak a piece of cotton cloth (as per ISO 105) until saturation with the mixture defined in paragraph 2.2.2.1. above and, within 10 seconds, apply it for 10 minutes to the outer face of the sample at a pressure of 50N/cm<sup>2</sup>, corresponding to an effort of 100N applied on a test surface of 14 x 14mm.

During this 10-minute period, the cloth pad shall be soaked again with the mixture so that the composition of the liquid applied is continuously identical with that of the test mixture prescribed.

During the period of application, it is permissible to compensate the pressure applied to the sample in order to prevent it from causing cracks.

#### 2.2.2.3. Cleaning

At the end of the application of the test mixture, the samples shall be dried in the open air and then washed with the solution described in paragraph 2.3. (resistance to detergents) at 23 degrees C +/- 5 degrees C.

Afterwards the samples shall be carefully rinsed with distilled water containing not more than 0.2% impurities at 23 degrees C +/- 5 degrees C and then wiped off with a soft cloth.

#### 2.2.3. Results

##### 2.2.3.1. After the test of resistance to atmospheric agents, the outer face of the samples shall be free from cracks, scratches, chipping and deformation, and the mean variation in transmission

$$\Delta t = \frac{T_2 - T_3}{T_2}$$

measured on the three samples according to the procedure described in Appendix 2 to this Annex shall not exceed 0.020 ( $\Delta t_m < 0.020$ ).

##### 2.2.3.2. After the test of resistance to chemical agents, the samples shall not bear any traces of chemical staining likely to cause a variation of flux diffusion, whose mean variation

$$\Delta d = \frac{T_5 - T_4}{T_2}$$

measured on the three samples according to the procedure described in Appendix 2 to this Annex shall not exceed 0.020 ( $\Delta t_m < 0.020$ ).

#### 2.3. Resistance to detergents and hydrocarbons

##### 2.3.1. Resistance to detergents

The outer face of three samples (lenses or samples of material) shall be heated to 50 degrees C +/- 5 degrees C and then immersed for five minutes in a mixture maintained at 23 degrees C +/- 5 degrees C and composed of 99 parts distilled water containing not more than 0.02% impurities and one part alkylaryl sulphonate.

At the end of the test, the samples shall be dried at 50 degrees C +/- 5 degrees C. The surface of the samples shall be cleaned with a moist cloth.

##### 2.3.2. Resistance to hydrocarbons

The outer face of these three samples shall then be lightly rubbed for one minute with a cotton cloth soaked in a mixture composed of 70% n-heptane and 30% toluene (volume %), and shall then be dried in the open air.

##### 2.3.3. Results

After the above two tests have been performed successively, the mean value of the variation in transmission

$$\Delta t = \frac{T_2 - T_3}{T_2} \left| \right.$$

measured on the three samples according to the procedure described in Appendix 2 to this Annex shall not exceed 0.010. ( $t_m$ 0.010)

## 2.4. Resistance to mechanical deterioration

### 2.4.1. Mechanical deterioration method

The outer face of the three new samples (lenses) shall be subjected to the uniform mechanical deterioration test by the method described in Appendix 3 to this Annex.

### 2.4.2. Results

After this test, the variations: in transmission:

$$\Delta t = \frac{T_2 - T_3}{T_2} \left| \right.$$

and in diffusion:

$$\Delta d = \frac{T_5 - T_4}{T_2}$$

shall be measured according to the procedure described in Appendix 2 in the area specified in paragraph 2.2.4 above. The mean value of the three samples shall be such that:

$$\Delta t_m < 0.100;$$

$$\Delta d_m < 0.050.$$

## 2.5. Test of adherence of coatings, if any

### 2.5.1. Preparation of the sample

A surface of 20mm x 20mm in area of the coating of a lens shall be cut with a razor blade or a needle into a grid of squares approximately 2mm x 2mm. The pressure on the blade or needle shall be sufficient to cut at least the coating.

### 2.5.2. Description of the test

Use an adhesive tape with a force of adhesion of 2N/(cm of width) +/- 20% measured under the standardized conditions specified in Appendix 4 to this Annex. This adhesive tape, which shall be at least 25mm wide, shall be pressed for at least five minutes to the surface prepared as prescribed in paragraph 2.5.1.

Then the end of the adhesive tape shall be loaded in such a way that the force of adhesion to the surface considered is balanced by a force perpendicular to that surface. At this stage, the tape shall be torn off at a constant speed of 1.5m/s +/- 0.2m/s.

2.5.3. Results

There shall be no appreciable impairment of the gridded area. Impairments at the intersections between squares or at the edges of the cuts shall be permitted, provided that the impaired area does not exceed 15% of the gridded surface.

2.6. Tests of the complete headlamp incorporating a lens of plastic material

2.6.1. Resistance to mechanical deterioration of the lens surface

2.6.1.1. Tests

The lens of lamp sample No. 1 shall be subjected to the test described in paragraph 2.4.1. above.

2.6.1.2. Results

After the test, the results of photometric measurements carried out on the headlamp in accordance with this Regulation shall not exceed by more than 30% the maximum values prescribed at points B50L and HV and not be more than 10% below the minimum values prescribed at point 75R (in the case of headlamps intended for left-hand traffic, the points to be considered are B50R, HV and 75L).

2.6.2. Test of adherence of coatings, if any

The lens of lamp sample No. 2 shall be subjected to the test described in paragraph 2.5. above.

**3. VERIFICATION OF THE CONFORMITY OF PRODUCTION**

3.1. With regard to the materials used for the manufacture of lenses, the lamps of a series shall be recognized as complying with this Regulation if:

3.1.1. After the test for resistance to chemical agents and the test for resistance to detergents and hydrocarbons, the outer face of the samples exhibits no cracks, chipping or deformation visible to the naked eye (see paragraphs 2.2.2., 2.3.1. and 2.3.2.);

3.1.2. After the test described in paragraph 2.6.1.1., the photometric values at the points of measurement considered in paragraph 2.6.1.2. are within the limits prescribed for conformity of production by this Regulation.

3.2. If the test results fail to satisfy the requirements, the tests shall be repeated on another sample of headlamps selected at random.

**Annex 6 Appendix 1**

**CHRONOLOGICAL ORDER OF APPROVAL TESTS**

A. Tests on plastic materials (lenses or samples of material supplied pursuant to paragraph 2.2.4. of this Regulation)

Tests Samples	Lenses or samples of material						Lenses						
	1	2	3	4	5	6	7	8	9	10	11	12	13
1. 1. Limited photometry (para. 2.1.2.)										X	X	X	
1. 1. 1. Temperature change (para. 2. 1. L)										X	X	X	
1. 1.2. Limited photometry (para. 2.1.2.)										X	X	X	
1.2. 1. Transmission measurement	X	X	X	X	X	X	X	X	X				
1.2.2. Diffusion measurement	X	X	X				X	X	X				
1. ~. Atmospheric agents (para. 2.2. 1.)	X	X	X										
1. ~. 1. Transmission measurement	X	X	X										
1.4. Chemical agents (para. 2.2.2.)	X	X	X										
1.4. 1. Diffusion measurement	X	X	X										
1.5. Detergents (para. 2.3. 1.)				X	X	X							
1.6. Hydrocarbons (para. 2.3.2.)				X	X	X							
1.6. 1. Transmission measurement				X	X	X							
1.7. Deterioration (2.4. L)							X	X	X				
1.7. 1. Transmission measurement							X	X	X				
1.7.2. Diffusion measurement							X	X	X				
1.8. Adherence (para. 2.5.)													X

B. Tests on complete lamps (supplied pursuant to paragraph 2.2.3. of this Regulation)

Test	Complete headlamp	
	Sample No.	
	2	
2. 1. Deterioration (para. 2.6.1. L)	X	X
2.2. Photometry (para. 2.6.1.1)	X	
2.3. Adherence (para. 2.6.1)		

## Annex 6 - Appendix 2

### METHOD OF MEASUREMENT OF THE DIFFUSION AND TRANSMISSION OF LIGHT

#### 1. EQUIPMENT (see Figure)

The beam of a collimator K with a half divergence  $\beta/2 = 17.4 \times 10^{-4}$  rd is limited by a diaphragm  $D_T$  with an opening of 6mm against which the sample stand is placed.

A convergent achromatic lens  $L_2$ , corrected for spherical aberrations, links the diaphragm  $D_T$  with the receiver R; the diameter of the lens  $L_2$  shall be such that it does not diaphragm the light diffused by the sample in a cone with a half top angle of  $\beta/2 = 14$  degrees.

An annular diaphragm  $D_D$  with angles  $\alpha/2 = 1$  degree and  $\alpha_{max}/2 = 12$  degrees is placed in an image placed in an image focal plane of the lens  $L_2$ .

The non-transparent central part of the diaphragm is necessary in order to eliminate the light arriving directly from the light source. It shall be possible to remove the central part of the diaphragm from the light beam in such a manner that it returns exactly to its original position.

The distance  $L_2 D_T$  and the focal length  $F_2^{1/}$  of the lens  $L_2$  shall be so chosen that the image of  $D_T$  completely covers the receiver R.

When the initial incident flux is referred to 1,000 units, the absolute precision of each reading shall be better than 1 unit.

#### 2. MEASUREMENTS

The following readings shall be taken:

Reading	With Sample	With central part of $D_D$	Quantity represented
T <sub>1</sub>	No	No	Incident flux in initial reading
T <sub>2</sub>	Yes (before test)	No	Flux transmitted by the new material in a field of 24 degrees C
T <sub>3</sub>	Yes (after test)	No	Flux transmitted by the tested material in a field of 24 degrees C
T <sub>4</sub>	Yes (before test)	Yes	Flux diffused by the new material
T <sub>5</sub>	Yes (after test)	Yes	Flux diffused by the tested material

<sup>1/</sup> For  $L_2$  it is recommended to use a focal distance of about 80mm.

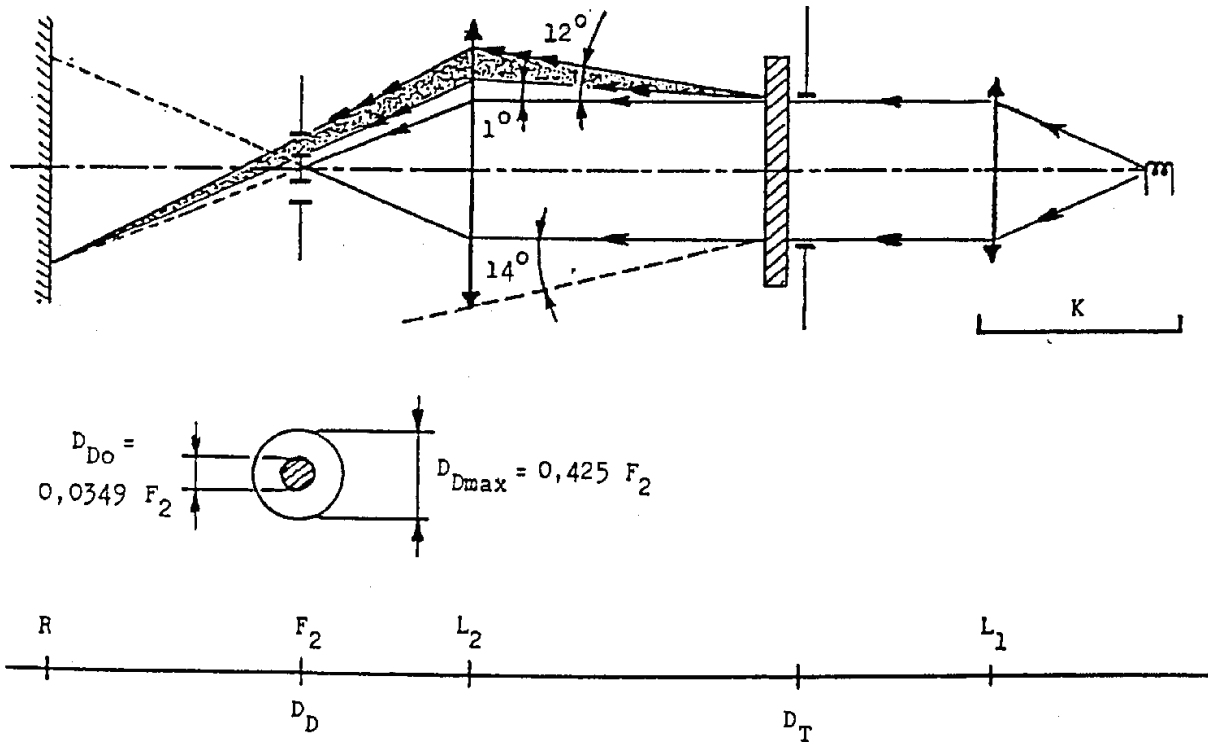

## **Annex 6 - Appendix 3**

### **SPRAY TESTING METHOD**

#### **1. Test equipment**

##### **1.1. Spray gun**

The spray gun used shall be equipped with a nozzle 1.3mm in diameter allowing a liquid flow rate of 0.24 +/- 0.02 l/minutes at an operating pressure of 6.0 bars -0, +0.5 bar. Under these operation conditions, the fan pattern obtained shall be 170mm +/- 50mm in diameter on the surface exposed to deterioration, at a distance of 380mm +/- 10mm from the nozzle.

##### **1.2. Test mixture**

The test mixture shall be composed of:

Silica sand of hardness 7 on the Mohr scale, with a grain size between 0 and 0.2mm and an almost normal distribution, with an angular factor of 1.8 to 2;

Water of hardness not exceeding 205g/m<sup>3</sup> for a mixture comprising 25g of sand per litre of water.

#### **2. Test**

The outer surface of the lamp lenses shall be subjected once or more than once to the action of the sand jet produced as described above. The jet shall be sprayed almost perpendicular to the surface to be tested.

The deterioration shall be checked by means of one or more samples of glass placed as a reference near the lenses to be tested. The mixture shall be sprayed until the variation in the diffusion of light on the sample or samples measured by the method described in Appendix 2, is such that:

$$\Delta d = \frac{T_5 - T_4}{T_2} = 0.0250 \pm 0.0025$$

Several reference samples may be used to check that the whole surface to be tested has deteriorated homogeneously.

## **Annex 6 - Appendix 4**

### **ADHESIVE TAPE ADHERENCE TEST**

#### **1. PURPOSE**

This method allows to determine under standard conditions the linear force of adhesion of an adhesive tape to a glass plate.

#### **2. PRINCIPLE**

Measurement of the force necessary to unstick an adhesive tape from a glass plate at an angle of 90 degrees.

#### **3. SPECIFIED ATMOSPHERIC CONDITIONS**

The ambient conditions shall be at 23 degrees +/- 5 degrees C and 65 +/- 15% relative humidity (RH).

#### **4. TEST PIECES**

Before the test, the sample roll of adhesive tape shall be conditioned for 24 hours in the specified atmosphere (see paragraph 3 above).

Five test pieces, each 400mm, long shall be tested from each roll. These test pieces shall be taken from the roll after the first three turns were discarded.

#### **5. PROCEDURE**

The test shall be under the ambient conditions specified in paragraph 3.

Take the five test pieces while unrolling the tape radially at a speed of approximately 30mm/s, then apply them within 15 seconds in the following manner:

Apply the tape to the glass plate progressively with a slight lengthwise rubbing movement of the finger, without excessive pressure, in such a manner as to leave no air bubble between the tape and the glass plate.

Leave the assembly in the specified atmospheric conditions for 10 minutes.

Unstick about 25mm of the test piece from the plate in a plane perpendicular to the axis of the test piece.

Fix the plate and fold back the free end of the tape at 90 degrees. Apply force in such a manner that the separation line between the tape and the plate is perpendicular to this force and perpendicular to the plate.

Pull to unstick at a speed of 300mm/s +/- 30mm/s and record the force required.

#### **6. RESULTS**

The five values obtained shall be arranged in order and the median value taken as the result of the measurement. This value shall be expressed in Newtons per centimetre of width of the tape.

## Annex 7

### MINIMUM REQUIREMENTS FOR SAMPLING BY AN INSPECTOR

#### 1. GENERAL

- 1.1. The conformity requirements shall be considered satisfied from a mechanical and a geometric standpoint, in accordance with the requirements of this Regulation, if any, if the differences do not exceed inevitable manufacturing deviations.
- 1.2. With respect to photometric performance, the conformity of mass-produced headlamps shall not be contested if, when testing photometric performances of any headlamp chosen at random and equipped with a standard filament lamp;
- 1.2.1. no measured value deviates unfavourably by more than 20% from the values prescribed in this Regulation.
- For values B50L (or R) and Zone III the maximum deviation may be respectively:
- |              |                       |
|--------------|-----------------------|
| B50L (or R): | 0.2lx equivalent 20%  |
|              | 0.3lx equivalent 30%  |
| Zone III:    | 0.3lx equivalent 20%  |
|              | 0.45lx equivalent 30% |
- 1.2.2. or if
- 1.2.2.1. for the passing beam, the values prescribed in this Regulation are met at HV (with a tolerance of 0.2lx) and related to that aiming at least one point of each area delimited on the measuring screen (at 25m) by a circle 15cm in radius around points B50L (or R)<sup>1/</sup> (with a tolerance of 0.1lx), 75 R (or L), 50V, 25R, 25L, and in the entire area of zone IV which is not more than 22.5cm above line 25R and 25L;
- 1.2.2.2. and if, for the driving beam, HV being situated within the isolux 0.75 E<sub>max</sub>, a tolerance of +20% for maximum values and -20% for minimum values is observed for the photometric values at any measuring point specified in paragraph 6.3.2. of this Regulation. The reference mark is disregarded.
- 1.2.3. If the results of the tests described above do not meet the requirements, the alignment of the headlamp may be changed, provided that the axis of the beam is not displaced laterally by more than 1 degrees to the right or left.<sup>14/</sup>
- 1.2.4. If the results of the tests described above do not meet the requirements, tests on the headlamps shall be repeated using another standard filament lamp.
- 1.2.5. Headlamps with apparent defects are disregarded.
- 1.2.6. The reference mark is disregarded.
- 1.3. The chromaticity coordinates shall be complied with when the headlamp is equipped with a filament lamp set to Standard A colour temperature.

<sup>1/</sup> Letters in brackets refer to headlamps intended for left-hand traffic.

<sup>14/</sup> See the corresponding footnote in the text of the Regulation.

The photometric performance of a headlamp emitting selective yellow light when equipped with a colourless filament lamp shall be the values contained in this Regulation multiplied by 0.84.

## 2. FIRST SAMPLING

In the first sampling four headlamps are selected at random. The first sample of two is marked A, the second sample of two is marked B.

### 2.1. The conformity is not contested

2.1.1. Following the sampling procedure shown in Figure 1 of this Annex the conformity of mass-produced headlamps shall not be contested if the deviation of the measured values of the headlamps in the unfavourable directions are:

#### 2.1.1.1. sample A

A1:	one headlamp	0%
	one headlamp not more than	20%
A2:	both headlamps more than	0%
	but not more than	20%

go to sample B

#### 2.1.1.2. sample B

B1:	both headlamps	0%
-----	----------------	----

2.1.2. or if the conditions of paragraph 1.2.2. for sample A are fulfilled.

### 2.2. The conformity is contested

2.2.1. Following the sampling procedure shown in Figure 1 of this Annex the conformity of mass-produced headlamps shall be contested and the manufacturer requested to make his production meet the requirements (alignment) if the deviations of the measured values of the headlamps are:

#### 2.2.1.1. sample A

A3:	one headlamp not more than	20%
	one headlamp more than	20%
	but not more than	30%

#### 2.2.1.2. sample B

B2: in the case of A2

	one headlamp more than	0%
	but not more than	20%
	one headlamp not more than	20%

B3: in the case of A2

	one headlamp	0%
	one headlamp more than	20%
	but not more than	30%

2.2.2. or if the conditions of paragraph 1.2.2. for sample A are not fulfilled.

2.3. Approval withdrawn

Conformity shall be contested and paragraph 13 applied if, following the sampling procedure in Figure 1 of this Annex, the deviations of the measured values of the headlamps are:

2.3.1. sample A

A4:	one headlamp not more than	20%
	one headlamp more than	30%
A5:	both headlamps more than	20%

2.3.2. sample B

B4: in the case of A2

	one headlamp more than	0%
	but not more than	20%
	one headlamp more than	20%

B5: in the case of A2

	both headlamps more than	20%
--	--------------------------	-----

B6: in the case of A2

	one headlamp	0%
	one headlamp more than	30%

2.3.3. or if the conditions of paragraph 1.2.2. for samples A and B are not fulfilled.

**3. REPEATED SAMPLING**

In the cases of A3, B2, B3 a repeated sampling, third sample C of two headlamps and fourth sample D of two headlamps, selected from stock manufactured after alignment, is necessary within two months time after the notification.

3.1. The conformity is not contested

3.1.1. Following the sampling procedure shown in Figure 1 of this Annex the conformity of mass-produced headlamps shall not be contested if the deviations of the measured values of the headlamps are:

3.1.1.1. sample C

C1:	one headlamp	0%
	one headlamp not more than	20%
C2:	both headlamps more than	0%
	but not more than	20%

go to sample D

- 
- 3.1.1.2. sample D  
D1: in the case of C2  
both headlamps 0%
- 3.1.2. or if the conditions of paragraph 1.2.2. for sample C are fulfilled.
- 3.2. The conformity is contested
- 3.2.1. Following the sampling procedure shown in Figure 1 of this Annex the conformity of mass-produced headlamps shall be contested and the manufacturer requested to make his production meet the requirements (alignment) if the deviations of the measured values of the headlamps are:
- 3.2.1.1. sample D  
D2: in the case of C2  
one headlamp more than 0%  
but not more than 20%  
one headlamp not more than 20%
- 3.2.1.2. or if the conditions of paragraph 1.2.2. for sample C are not fulfilled:
- 3.3. Approval withdrawn  
Conformity shall be contested and paragraph 13 applied if, following the sampling procedure in Figure 1 of this Annex, the deviations of the measured values of the headlamps are:
- 3.3.1. sample C  
C3: one headlamp not more than 20%  
one headlamp more than 20%  
C4: both headlamps more than 20%
- 3.3.2. sample D  
D3: in the case of C2  
one headlamp 0 or more than 0%  
one headlamp more than 20%
- 3.3.3. or if the conditions of paragraph 1.2.2. for samples C and D are not fulfilled.
- 4. CHANGE OF THE VERTICAL POSITION OF THE CUT-OFF LINE**  
With respect to the verification of the change in vertical positions of the cut-off line under the influence of heat, the following procedure shall be applied:  
One of the headlamps of sample A after sampling procedure in Figure 1 of this Annex shall be tested according to the procedure described in paragraph 2.1. of Annex 5 after being subjected three consecutive times to the cycle described in paragraph 2.2.2. of Annex 5.  
The headlamp shall be considered as acceptable if  $D_r$  does not exceed 1.5mrad.



**UNITED  
NATIONS**

**E**



**Economic and Social  
Council**

Distr.

GENERAL

TRANS/WP.29/623  
11 May 1998

ENGLISH

Original: ENGLISH  
and FRENCH

**ECONOMIC COMMISSION FOR EUROPE INLAND TRANSPORT COMMITTEE**  
**Working Party on the Construction of Vehicles**

**DRAFT SUPPLEMENT 10 TO THE 04 SERIES OF AMENDMENTS TO REGULATION  
NO. 8 (Headlamps (H<sub>1</sub>, H<sub>2</sub>, H<sub>3</sub>, HB<sub>3</sub>, HB<sub>4</sub>, H<sub>7</sub>, H<sub>8</sub>, HIR<sub>1</sub> and/or HIR<sub>2</sub>))**

Note: The text reproduced below was adopted by the Administrative Committee (AC.1) of the amended 1958 Agreement at its eighth session, following the recommendation by the Working Party at its one-hundred-and-fourteenth session. It is based on document TRANS/WP.29/1998/14, as corrected (TRANS/WP.29/609, paras. 54 and 107).

Title, amend the words "... FILAMENT LAMPS (H<sub>1</sub>, H<sub>2</sub>, H<sub>3</sub>, HB<sub>3</sub>, HB<sub>4</sub>, H<sub>7</sub>, H<sub>8</sub>, H<sub>9</sub>, HIR<sub>1</sub>, and/or HIR<sub>2</sub>)" to read: "... FILAMENT LAMPS (H<sub>1</sub>, H<sub>2</sub>, H<sub>3</sub>, HB<sub>3</sub>, HB<sub>4</sub>, H<sub>7</sub>, H<sub>8</sub>, H<sub>9</sub>, HIR<sub>1</sub>, HIR<sub>2</sub> and/or H<sub>11</sub>)".

List of Contents, annexes, title of annex 2, amend to read:

"Annex 2 - Verification of conformity of production of headlamps equipped with H<sub>1</sub>, H<sub>2</sub>, H<sub>3</sub>, HB<sub>3</sub>, HB<sub>4</sub>, H<sub>7</sub>, H<sub>8</sub>, H<sub>9</sub>, HIR<sub>1</sub>, HIR<sub>2</sub> and/or H<sub>11</sub> filament lamps"

Paragraph 1.3.6., amend to read:

"1.3.6. the holder intended to accommodate the filament lamp (or lamps) of one of the categories H<sub>1</sub>, H<sub>2</sub>, H<sub>3</sub>, HB<sub>3</sub>, HB<sub>4</sub>, H<sub>7</sub>, H<sub>8</sub>, H<sub>9</sub>, HIR<sub>1</sub>, HIR<sub>2</sub> and/or H<sub>11</sub>; 2/ \*/"

Note<sup>2/</sup> (pertinent to paragraph 1.3.6.), amend to read:

"... of categories H<sub>1</sub>, H<sub>2</sub>, H<sub>3</sub>, HB<sub>3</sub>, HB<sub>4</sub>, H<sub>7</sub>, H<sub>8</sub>, H<sub>9</sub>, HIR<sub>1</sub>, HIR<sub>2</sub> and/or H<sub>11</sub>...."

Footnote<sup>\*/</sup>, (pertinent to paragraph 1.3.6.), amend to read:

"\*/ HIR<sub>1</sub> and/or H<sub>9</sub> filament lamps shall only be permitted to produce passing beam in conjunction with the installation of headlamp cleaning device(s) conforming to Regulation No. 45. In addition, with respect to vertical inclination, the provision of paragraph 6.2.6.2.2. of Regulation No. 48, 01 series of amendments, shall not be applied when these headlamps are installed.

This restriction shall apply as long as there is no general agreement on the use of levelling devices and headlamp cleaners with respect to the level of the performance of the headlamp."

Paragraph 5.3., add a new line to the existing table, to read:

"H<sub>11</sub> PGJ 19-2 7005-110-1"

Paragraph 6.1.1., amend to read:

"... with suitable H<sub>1</sub>, H<sub>2</sub>, H<sub>3</sub>, HB<sub>3</sub>, HB<sub>4</sub>, H<sub>7</sub>, H<sub>8</sub>, H<sub>9</sub>, HIR<sub>1</sub>, HIR<sub>2</sub> and/or H<sub>11</sub>  
filament lamps ..."

Paragraph 6.1.3., add a new line to the existing table, to read:

"H<sub>11</sub> 12 1000"

Annex 2, title, amend to read:

"... EQUIPPED WITH H<sub>1</sub>, H<sub>2</sub>, H<sub>3</sub>, HB<sub>3</sub>, HB<sub>4</sub>, H<sub>7</sub>, H<sub>8</sub>, H<sub>9</sub>, HIR<sub>1</sub>, HIR<sub>2</sub> and/or H<sub>11</sub>  
FILAMENT LAMPS"

## **APPENDIX D**

### UN REGULATION No. 20/02

UNIFORM PROVISIONS CONCERNING THE APPROVAL OF MOTOR VEHICLE  
HEADLAMPS EMITTING AN ASYMMETRICAL PASSING BEAM OR DRIVING  
BEAM OR BOTH EQUIPPED WITH HALOGEN FILAMENT LAMPS (H4 LAMPS)

## Regulation No. 20

# UNIFORM PROVISIONS CONCERNING THE APPROVAL OF MOTOR VEHICLE HEADLAMPS EMITTING AN ASYMMETRICAL PASSING BEAM OR A DRIVING BEAM OR BOTH AND EQUIPPED WITH HALOGEN FILAMENT LAMPS (H4 LAMPS)

## CONTENTS

### REGULATION

- A. ADMINISTRATIVE PROVISIONS
  - Scope
  - 1. Definitions
  - 2. Application for approval of a headlamp
  - 3. Markings
  - 4. Approval
- B. TECHNICAL REQUIREMENTS FOR HEADLAMPS
  - 5. General specifications
  - 6. Illumination
  - 7. Provisions concerning coloured lenses and filters
  - 8. Gauging of discomfort
  - 9. Standard (reference) headlamp
  - 10. Observation concerning colour
- C. FURTHER ADMINISTRATIVE PROVISIONS
  - 11. Modification of the headlamp type and extension of approval
  - 12. Conformity of production
  - 13. Penalties for non-conformity of production
  - 14. Production definitely discontinued
  - 15. Names and addresses of technical services responsible for conducting approval tests, and of administrative departments

### ANNEXES

- Annex 1 Communication concerning the approval or refusal or extension or withdrawal of approval (or production definitely discontinued) of a type of headlamp pursuant to Regulation No. 20
- Annex 2 Arrangements of approval marks
- Annex 3 Measuring screen
- Annex 4 Tests for stability of photometric performance of headlamps in operation
- Annex 5 Minimum requirements for conformity of production control procedures.
- Annex 6 Requirements for lamps incorporating lenses of plastic material-testing of lens or material samples and of complete lamps
- Appendix 1
- Appendix 2
- Appendix 3
- Appendix 4
- Annex 7 Minimum requirements for sampling by an inspector

## Regulation No. 20

### UNIFORM PROVISIONS CONCERNING THE APPROVAL OF MOTOR VEHICLE HEADLAMPS EMITTING AN ASYMMETRICAL PASSING BEAM OR A DRIVING BEAM OR BOTH AND EQUIPPED WITH HALOGEN FILAMENT LAMPS (H4 LAMPS)

#### A. ADMINISTRATIVE PROVISIONS

##### SCOPE <sup>1/</sup>

This Regulation applies to motor vehicle headlamps which may incorporate lenses of glass or plastic material.

##### 1. DEFINITIONS

For the purpose of this Regulation,

- 1.1. "Lens" means the outermost component of the headlamp (unit) which transmits light through the illuminating surface;
- 1.2. "Coating" means any product or products applied in one or more layers to the outer face of a lens;
- 1.3. Headlamps of different "types" are headlamps which differ in such essential respects as:
  - 1.3.1. the trade name or mark;
  - 1.3.2. the characteristics of the optical system;
  - 1.3.3. the inclusion or elimination of components capable of altering the optical effects by reflection, refraction, absorption and/or deformation during operation. However, the fitting or elimination of filters intended solely to change the colour of the beam but not its light distribution does not entail a change of type;
  - 1.3.4. suitability for right-hand or left-hand traffic or for both traffic systems;
  - 1.3.5. the kind of beam produced (passing beam, driving beam or both);
  - 1.3.6. the materials constituting the lenses and coating, if any.

##### 2. APPLICATION FOR APPROVAL OF A HEADLAMP <sup>2/</sup>

- 2.1. The application for approval shall be submitted by the owner of the trade name or mark or by his duly accredited representative. It shall specify:
  - 2.1.1. whether the headlamp is intended to provide both a passing beam and a driving beam or only one of these beams;
  - 2.1.2. whether, if the headlamp is intended to provide a passing beam, it is designed for both left-hand and right-hand traffic or for either left-hand or right-hand traffic only.

---

<sup>1/</sup> Nothing in this Regulation shall prevent a Party to the Agreement applying this Regulation from prohibiting the combination of a headlamp incorporating a lens of plastic material approved under this Regulation with a mechanical headlamp-cleaning device (with wipers).

<sup>2/</sup> Application for approval of a filament lamp: see Regulation No. 37.

- 2.1.3. if the headlamp is equipped with an adjustable reflector, the mounting position(s) of the headlamp in relation to the ground and the longitudinal median plane of the vehicle.
- 2.2. Every application for approval shall be accompanied by:
  - 2.2.1. drawings in triplicate in sufficient detail to permit identification of the type and representing a frontal view of the headlamp, with details of lens ribbing if any, and the cross-section; the drawings shall indicate the space reserved for the approval mark;
    - 2.2.1.1. if the headlamp is equipped with an adjustable reflector, an indication of the mounting position(s) of the headlamp in relation to the ground and the longitudinal median plane of the vehicle, if the headlamp is for use in that (those) position(s) only;
    - 2.2.2. a brief technical description;
    - 2.2.3. two samples of the type of headlamp;
      - 2.2.3.1. for the testing of a coloured filter or coloured screen (or of a coloured lens): two samples.
    - 2.2.4. For the test of plastic material of which the lenses are made:
      - 2.2.4.1. thirteen lenses;
        - 2.2.4.1.1. six of these lenses may be replaced by six samples of material at least 60 x 80 mm in size, having a flat or convex outer surface and a substantially flat area (radius of curvature not less than 300 mm) in the middle measuring at least 15 x 15 mm;
        - 2.2.4.1.2. every such lens or sample of material shall be produced by the method to be used in mass production;
      - 2.2.4.2. a reflector to which the lenses can be fitted in accordance with the manufacturer's instructions.
  - 2.3. The materials making up the lenses and coatings, if any, shall be accompanied by the test report of the characteristics of these materials and coatings if they have already been tested.
  - 2.4. The competent authority shall verify the existence of satisfactory arrangements for ensuring effective control on the conformity of production before type approval is granted.
- 3. MARKINGS**<sup>3/</sup>
  - 3.1. Headlamps submitted for approval shall bear the trade name or mark of the applicant.
  - 3.2. They shall comprise, on the lens and on the main body,<sup>4/</sup> spaces of sufficient size for the approval mark and the additional symbols referred to in paragraph 4; these spaces shall be indicated on the drawings referred to in paragraph 2.2.1. above.

---

<sup>3/</sup> In the case of headlamps designed to meet the requirements of traffic moving on one side of the road only (either right or left), it is further recommended that the area which can be occulted to prevent discomfort to users in a country where traffic moves on the side of the road opposite to that of the country for which the headlamp was designed should be outlined indelibly on the front lens. This marking is not necessary, however, where the area is clearly apparent from the design.

<sup>4/</sup> If the lens cannot be detached from the main body of the headlamp, a space on the lens shall be sufficient.

- 3.3. Headlamps designed to satisfy the requirements both of right-hand and of left-hand traffic shall bear markings indicating the two settings of the optical unit on the vehicle or of the filament lamp on the reflector; these markings shall consist of the letters "R/D" for the position for right-hand traffic and the letters "L/G" for the position for left-hand traffic.

#### 4. APPROVAL

##### 4.1. General

- 4.1.1. If all the samples of a type of headlamp submitted pursuant to paragraph 2 above satisfy the provisions of this Regulation, approval shall be granted.
- 4.1.2. Where grouped, combined or reciprocally incorporated lamps satisfy the requirements of more than one Regulation, a single international approval mark may be affixed provided that each of the grouped, combined or reciprocally incorporated lamps satisfies the provisions applicable to it.
- 4.1.3. An approval number shall be assigned to each type approved. Its first two digits (at present 02) shall indicate the series of amendments incorporating the most recent major technical amendments made to the Regulation at the time of issue of the approval. The same Contracting Party may not assign the same number to another type of headlamp covered by this Regulation, except if the approval is extended to a device which only differs from the already approved device by the colour of the light emitted.
- 4.1.4. Notice of approval or of extension or refusal or withdrawal of approval or production definitely discontinued of a type of headlamp pursuant to this Regulation shall be communicated to the Parties to the 1958 Agreement applying this Regulation, by means of a form conforming to the model in Annex 1 to this Regulation, with the indications according to paragraph 2.2.1.1.
- 4.1.4.1. if the headlamp is equipped with an adjustable reflector and if this headlamp is to be used only in mounting positions according to the indications in paragraph 2.2.1.1., the applicant shall be obliged by the approval to inform the user in a proper way about the correct mounting position(s).
- 4.1.5. In addition to the mark prescribed in paragraph 3.1, an approval mark as described in paragraphs 4.2. and 4.3. below shall be affixed in the spaces referred to in paragraph 3.2. above to every headlamp conforming to a type approved under this Regulation.

##### 4.2. Composition of the approval mark

The approval mark shall consist of:

- 4.2.1. An international approval marking, comprising:
- 4.2.1.1. a circle surrounding the letter "E" followed by the distinguishing number of the country which has granted approval;<sup>5/</sup>

---

<sup>5/</sup> 1 for Germany, 2 for France, 3 for Italy, 4 for the Netherlands, 5 for Sweden, 6 for Belgium, 7 for Hungary, 8 for the Czech Republic, 9 for Spain, 10 for Yugoslavia, 11 for the United Kingdom, 12 for Austria, 13 for Luxembourg, 14 for Switzerland, 15 (vacant), 16 for Norway, 17 for Finland, 18 for Denmark, 19 for Romania, 20 for Poland, 21 for Portugal and 22 for the Russian Federation, 23 for Greece, 24 and 25 (vacant), 26 for Slovenia, and 27 for Slovakia, 28 for Belarus and 29 for Estonia, 30 (vacant), 31 for Bosnia and Herzegovina, 32-36(vacant) and 37 for Turkey. Subsequent numbers will be assigned to other countries in the chronological order in which they ratify or accede to the Agreement concerning the Adoption of Uniform Conditions of

- 4.2.1.2. the approval number prescribed in paragraph 4.1.3. above;
- 4.2.2. the following additional symbol (or symbols):
  - 4.2.2.1. on headlamps meeting left-hand traffic requirements only, a horizontal arrow pointing to the right of an observer facing the headlamp, i.e. to the side of the road on which the traffic moves;
  - 4.2.2.2. on headlamps designed to meet the requirements of both traffic systems by means of an appropriate adjustment of the setting of the optical unit or the filament lamp, a horizontal arrow with a head on each end, the heads pointing respectively to the left and to the right;
  - 4.2.2.3. on headlamps meeting the requirements of this Regulation in respect of the passing beam only, the letters "HC";
  - 4.2.2.4. on headlamps meeting the requirements of this Regulation in respect of the driving beam only, the letters "HR";
  - 4.2.2.5. on headlamps meeting the requirements of this Regulation in respect of both the passing beam and the driving beam, the letters "HCR";
  - 4.2.2.6. on headlamps incorporating a lens of plastic material, the group of letters "PL" to be affixed near the symbols prescribed in paragraphs 4.2.2.3. to 4.2.2.5. above;
  - 4.2.2.7. on headlamps meeting the requirements of this Regulation in respect of the driving beam, an indication of the maximum luminous intensity expressed by a reference mark, as defined in paragraph 6.3.2.1.2. below, placed near the circle surrounding the letter "E";

In the case of reciprocally incorporated headlamps, indication of the maximum luminous intensity of the driving beams as a whole shall be expressed as above.

- 4.2.3. In every case the relevant operating mode used during the test procedure according to paragraph 1.1.1.1. of annex 4 and the permitted voltage(s) according to paragraph 1.1.1.2. of annex 4 shall be stipulated on the approval forms and on the communication forms transmitted to the countries which are Contracting Parties to the Agreement and which apply this Regulation.

In the corresponding cases the device shall be marked as follows:

- 4.2.3.1. On headlamps meeting the requirements of this Regulation which are so designed that the filament of the passing beam shall not be lit simultaneously with that of any other lighting function with which it may be reciprocally incorporated: an oblique stroke (/) shall be placed behind the passing lamp symbol in the approval mark.
- 4.2.3.2. On headlamps meeting the requirements of annex 4 to this Regulation only when supplied with a voltage of 6 V or 12 V, a symbol consisting of the number 24 crossed out by an oblique cross (x), shall be placed near the filament lamp holder.
- 4.2.4. The two digits of the approval number (at present 02) which indicate the series of amendments incorporating the most recent major technical amendments made to

---

Approval and Reciprocal Recognition of Approval for Motor Vehicle Equipment and Parts, and the numbers thus assigned shall be communicated to the Contracting Parties to the Agreement by the Secretary-General of the United Nations.

the Regulation at the time of issue of the approval and, if necessary, the required arrow may be marked close to the above additional symbols.

4.2.5. The marks and symbols referred to in paragraphs 4.2.1. and 4.2.2. above shall be clearly legible and be indelible even when the head lamp is fitted in the vehicle.

#### 4.3. Arrangement of the approval mark

##### 4.3.1. Independent lamps

Annex 2, figures 1 to 9, to this Regulation gives examples of arrangements of the approval mark with the above-mentioned additional symbols.

##### 4.3.2. Grouped, combined or reciprocally incorporated lamps

4.3.2.1. Where grouped, combined or reciprocally incorporated lamps have been found to comply with the requirements of several Regulations, a single international approval mark may be affixed, consisting of a circle surrounding the letter "E" followed by the distinguishing number of the country which has granted the approval, and an approval number. This approval mark may be located anywhere on the grouped, combined or reciprocally incorporated lamps, provided that:

4.3.2.1.1. it is visible after their installation;

4.3.2.1.2. no part of the grouped, combined or reciprocally incorporated lamps that transmits light can be removed without at the same time removing the approval mark.

4.3.2.2. The identification symbol for each lamp appropriate to each Regulation under which approval has been granted, together with the corresponding series of amendments incorporating the most recent major technical amendments to the Regulation at the time of issue of the approval, and if necessary, the required arrow shall be marked:

4.3.2.2.1. either on the appropriate light-emitting surface,

4.3.2.2.2. or in a group, in such a way that each of the grouped, combined or reciprocally incorporated lamps may be clearly identified (see four possible examples in annex 2).

4.3.2.3. The size of the components of a single approval mark shall not be less than the minimum size required for the smallest of the individual marks by the Regulation under which approval has been granted.

4.3.2.4. An approval number shall be assigned to each type approved. The same Contracting Party may not assign the same number to another type of grouped, combined or reciprocally incorporated lamps covered by this Regulation.

4.3.2.5. Annex 2, figure 10, to this Regulation gives examples of arrangements of approval marks for grouped, combined or reciprocally incorporated lamps with all the above- mentioned additional symbols.

4.3.3. Lamps, the lens of which are used for different types of headlamps and which may be reciprocally incorporated or grouped with other lamps

The provisions laid down in paragraph 4.3.2. above are applicable.

4.3.3.1. In addition, where the same lens is used, the latter may bear the different approval marks relating to the different types of headlamps or units of lamps, provided that the main body of the headlamp, even if it cannot be separated from the lens, also

comprises the space described in paragraph 3.2. above and bears the approval marks of the actual functions.

If different types of headlamps comprise the same main body, the latter may bear the different approval marks.

- 4.3.3.2. Annex 2, figure 11, to this Regulation gives examples of arrangements of approval marks relating to the above case.

## **B. TECHNICAL REQUIREMENTS FOR HEADLAMPS <sup>6/</sup>**

### **5. GENERAL SPECIFICATIONS**

- 5.1. Each sample shall conform to the specifications set forth in paragraph 6. to 8. below.
- 5.2. Headlamps shall be so made as to retain their prescribed photometric characteristics and to remain in good working order when in normal use, in spite of the vibrations to which they may be subjected.
- 5.2.1. Headlamps shall be fitted with a device enabling them to be so adjusted on the vehicles as to comply with the rules applicable to them. Such a device need not be fitted on units in which the reflector and the diffusing lens cannot be separated, provided the use of such units is confined to vehicles on which the headlamp setting can be adjusted by other means.

Where a headlamp providing a passing beam and a headlamp providing a driving beam, each equipped with its own filament lamp, are assembled to form a composite unit the adjusting device shall enable each optical system individually to be duly adjusted.

- 5.2.2. However, these provisions shall not apply to headlamp assemblies whose reflectors are indivisible. For this type of assembly the requirements of paragraph 6.3. of this Regulation shall apply.
- 5.3. The components by which the filament lamp is fixed to the reflector shall be so made that, even in darkness, the filament lamp can be fixed in no position but the correct one. <sup>7/</sup> The filament lamp holder shall conform to the characteristics given on data sheet 7005- 39-1 of IEC Publication 61-2, third edition, 1969.
- 5.4. Headlamps designed to satisfy the requirements both of right-hand and of left-hand traffic may be adapted for traffic on a given side of the road either by an appropriate initial setting when fitted on the vehicle or by selective setting by the user. Such initial or selective setting may consist, for example, of fixing either the optical unit at a given angle on the vehicle or the filament lamp at a given angle in relation to the optical unit. In all cases, only two different and clearly distinct settings, one for right-hand and one for left-hand traffic, shall be possible, and the design shall preclude inadvertent shifting from one setting to the other or setting in an intermediate position. Where two different setting positions are provided for the filament lamp, the components for attaching the filament lamp to the reflector must be so designed and made that, in each of its two settings, the filament lamp will be held in position with the precision required for headlamps designed for traffic on only one side of the road. Conformity with the requirements of this

<sup>6/</sup> Technical requirements for filament lamps: see Regulation No. 37.

<sup>7/</sup> A headlamp is regarded as satisfying the requirements of this paragraph if the filament lamp can be easily fitted into the headlamp and the feather keys can be correctly fitted into their slots even in darkness.

paragraph shall be verified by visual inspection and, where necessary, by a test fitting.

- 5.5. Complementary tests shall be done according to the requirements of annex 4 to ensure that in use there is no excessive change in photometric performance.
- 5.6. If the lens of the headlamp is of plastic material, tests shall be done according to the requirements of annex 6.

## 6. ILLUMINATION

### 6.1. General provisions

- 6.1.1. Headlamps shall be so made that with suitable H4 filament lamps they give adequate illumination without dazzle when emitting the passing beam, and good illumination when emitting the driving beam.
- 6.1.2. The illumination produced by the headlamp shall be determined by means of a vertical screen set up 25 m forward of the headlamp and at right angles to its axes as shown in annex 3 to this Regulation.
- 6.1.3. The headlamps shall be checked by means of an uncoloured standard (reference) filament lamp designed for a rated voltage of 12 V. In the case of headlamps which may be fitted with selective-yellow filters,<sup>8/</sup> such filters shall be replaced by geometrically identical uncoloured filters with a transmission factor of at least 80%. During the checking of the headlamp, the voltage at the terminals of the filament lamp must be regulated so as to obtain the following characteristics:

	Consumption in Watts	Light flux in lumens
Passing filament	About 55	750
Driving filament	About 60	1,250

The headlamp shall be considered acceptable if it meets the requirements of this paragraph 6 with at least one standard (reference) filament lamp, which may be submitted with the headlamp.

- 6.1.4. The dimensions determining the position of the filaments inside the standard filament lamp are shown in the relevant data sheets of Regulation No. 37.
- 6.1.5. The bulb of the standard filament lamp must be of such shape and optical quality that it does not cause any reflection or refraction adversely affecting the light distribution. Compliance with this requirement shall be checked by measuring the light distribution obtained when a standard (reference) headlamp is fitted with the standard (reference) filament lamp (see paragraph 9 below).

### 6.2. Provisions concerning passing beams

- 6.2.1. The passing beam must produce a sufficiently sharp "cut-off" to permit a satisfactory adjustment with its aid. The "cut-off" must be a horizontal straight line on the side opposite to the direction of the traffic for which the headlamp is intended; on the other side, it must not extend beyond either the broken line HV H1 H4 formed by a straight line HV H1 making a 45 degrees angle with the horizontal and the straight line H1 H4, 25 cm above the straight line hh, or the straight line HV H3, inclined at an angle of 15 degrees above the horizontal (see annex 4). A "cut-off" extending beyond both line HV H2 and line H2H4 and

---

<sup>8/</sup> These filters shall consist of all the components, including the lens, intended to colour the light (except those forming part of the filament lamp itself).

resulting from a combination of the two above possibilities shall in no circumstances be permitted.

- 6.2.2. The headlamp shall be so aimed that
  - 6.2.2.1. in the case of headlamps designed to meet the requirements of right-hand traffic, the "cut-off" on the left-half of the screen <sup>9/</sup> is horizontal and, in the case of headlamps designed to meet the requirements of left-hand traffic, the "cut-off" on the right-half of the screen is horizontal;
  - 6.2.2.2. this horizontal part of the "cut-off" is situated on the screen 25 cm below the level hh (see annex 4);
  - 6.2.2.3. the "elbow" of the "cut-off" is on line vv. <sup>10/</sup>
- 6.2.3. When so aimed, the headlamp need, if its approval is sought solely for provision of a passing beam, <sup>11/</sup> comply only with the requirements set out in paragraphs 6.2.5. to 6.2.7. below; if it is intended to provide both a passing beam and a driving beam, it shall comply with the requirements set out in paragraphs 6.2.5. to 6.2.7. and 6.3.
- 6.2.4. Where a headlamp so aimed does not meet the requirements set out in paragraphs 6.2.5. to 6.2.7. and 6.3., its alignment may be changed, provided that the axis of the beam is not displaced laterally by more than 1 degrees (= 44 cm) to the right or left. <sup>12/</sup> To facilitate alignment by means of the "cut-off", the headlamp may be partially occulted in order to sharpen the "cut-off".
- 6.2.5. The illumination produced on the screen by the passing beam shall meet the following requirements:

Point on measuring screen		Required illumination in lux
Headlamp for right-hand traffic	Headlamp for left-hand traffic	
Point B 50 L	Point B 50 L	
“ 75 R	“ 75 L	
“ 75 L	“ 75 R	
“ 50 L	“ 50 L	
“ 50 R	“ 50 R	
“ 50 V	“ 50 V	
“ 25 L	“ 25 R	
“ 25 R	“ 25 L	

<sup>9/</sup> The test screen must be sufficiently wide to allow examination of the "cut-off" over a range of at least 5 degrees on either side of the line vv.

<sup>10/</sup> If the beam does not have a cut-off with a clear "elbow", the lateral adjustment shall be effected in the manner which best satisfies the requirements for illumination at points 75 R and 50 R for right-hand traffic and for points 75 L and 50 L for left-hand traffic.

<sup>11/</sup> Such a special "passing beam" headlamp may incorporate a driving beam not subject to requirements.

<sup>12/</sup> The limit of realignment of 1 degrees towards the right or left is not incompatible with upward or downward vertical realignment. The latter is limited only by the requirements of paragraph 6.3. However, the horizontal part of the "cut-off" should not extend beyond the line hh (the provisions of paragraph 6.3. are not applicable to headlamps intended to meet the requirements of this Regulation only for provision of a passing beam).

Any point in zone III	< 0.7
Any point in zone IV	> 3
Any point in zone I < 2 x (E50R or E50L)*	< 2 x (E50R or E50L)*

\* E50R and E50L are the illuminations actually measured.

6.2.6. There shall be no lateral variations detrimental to good visibility in any of the zones I, II, III and IV.

6.2.7. The illumination values in zones "A" and "B"\*<sup>/</sup> as shown in Figure C in annex 3 shall be checked by the measurement of the photometric values of points 1 to 8 on this figure; these values shall lie within the following limits:

$$1 + 2 + 3 > 0.3 \text{ lux, and}$$

$$4 + 5 + 6 > 0.6 \text{ lux, and}$$

$$0.7 \text{ lux} > 7 > 0.1 \text{ lux and}$$

$$0.7 \text{ lux} > 8 > 0.2 \text{ lux}$$

These new values shall not be required for headlamps which have been approved before the application date of Supplement 3 to the 02 series of amendments to this Regulation (2 December 1992) nor to the extensions of such approvals.

6.2.8. Headlamps designed to meet the requirements of both right-hand and left-hand traffic must, in each of the two setting positions of the optical unit or of the filament lamp, meet the requirements set forth above for the corresponding direction of traffic.

### 6.3. Provisions concerning driving beams

6.3.1. In the case of a headlamp designed to provide a driving beam and a passing beam, measurements of the illumination produced on the screen by the driving beam shall be taken with the same headlamp alignment as for measurements under paragraphs 6.2.5. to 6.2.7. above; in the case of a headlamp providing a driving beam only, it shall be so adjusted that the area of maximum illumination is centred on the point of intersection of lines hh and vv; such a headlamp need meet only the requirements referred to in paragraph 6.3. Where more than one light source is used to provide the driving beam, the combined functions shall be used to determine the maximum value of the illumination (EM).

6.3.2. The illumination produced on the screen by the driving beam shall meet the following requirements.

6.3.2.1. The point of intersection (HV) of lines hh and vv shall be situated within the isolux 80% of maximum illumination. This maximum value (EM) shall not be less than 48 lux. The maximum value shall in no circumstances exceed 240 lux; in addition, in the case of a combined passing and driving headlamp, this maximum value shall not be more than 16 times the illumination measured for the passing beam at point 75 R (or 75 L).

6.3.2.1.1. The maximum intensity (IM) of the driving beam expressed in thousands of candelas shall be calculated by the formula

$$IM = 0.625 EM$$

---

\*<sup>/</sup> Illumination values in any point of zones A and B, which also lies within zone III, shall not exceed 0.7 lux.

- 6.3.2.1.2. The reference mark ( $I'_M$ ) of this maximum intensity, referred to in paragraph 4.2.2.7. above, shall be obtained by the ratio

$$I'_M = \frac{I_M}{3} = 0.208E_M$$

This value shall be rounded off to the value 7.5 12.5 - 17.5 25 - 27.5 37.5 45 - 50.

- 6.3.2.2. Starting from point HV, horizontally to the right and left, the illumination shall be not less than 24 lux up to a distance of 1.125 m and not less than 6 lux up to a distance of 2.25 m.

- 6.4. In the case of headlamps with an adjustable reflector the requirements of paragraphs 6.2. and 6.3. are applicable for each mounting position indicated according to paragraph 2.1.3. For verification the following procedure shall be used:

- 6.4.1. each applied position is realized on the test goniometer with respect to a line joining the centre of the light source and point HV on the aiming screen. The adjustable reflector is then moved into such a position that the light pattern on the screen corresponds to the aiming prescriptions of paragraphs 6.2.1. to 6.2.2.3. and/or 6.3.1;
- 6.4.2. with the reflector initially fixed according to paragraph 6.4.1., the headlamp must meet the relevant photometric requirements of paragraphs 6.2. and 6.3.;
- 6.4.3. additional tests are made after the reflector has been moved vertically +/-2 degrees or at least into the maximum position, if less than 2 degrees, from its initial position by means of the headlamps adjusting device. Having re-aimed the headlamp as a whole (by means of the goniometer for example) in the corresponding opposite direction the light output in the following directions shall be controlled and lie within the required limits: passing beam: points HV and 75R (75L respectively);  
driving beam: IM and point HV (percentage of IM).
- 6.4.4. if the applicant has indicated more than one mounting position the procedure of paragraphs 6.4.1. to 6.4.3. shall be repeated for all the other positions;
- 6.4.5. if the applicant has not asked for special mounting positions, the headlamp shall be aimed for measurements of paragraphs 6.2. and 6.3. with the headlamps adjusting device in its mean position. The additional tests of paragraph 6.4.3. shall be made with the reflector moved into its extreme positions (instead of +/-2 degrees) by means of the headlamps adjusting device.
- 6.5. The screen illumination values mentioned in paragraphs 6.2.5. to 6.2.7. and 6.3. above shall be measured by means of a photo-receptor, the effective area of which shall be contained within a square of 65 mm side.

## 7. PROVISIONS CONCERNING COLOURED LENSES AND FILTERS

- 7.1. Approval may be obtained for headlamps emitting either white or selective-yellow lights with an uncoloured filament lamp. Expressed in CIE trichromatic coordinates, the corresponding colorimetric characteristics for yellow lenses or filters are as follows: Selective-yellow filter (screen or lens)

Limit towards red

$$y > 0.138 + 0.58 x$$

Limit towards green	$y < 1.29x - 0.1$
Limit towards white	$y > -x + 0.966$
Limit towards spectral value	$y < -x + 0.992$

which can also be expressed as follows:

dominant wave-length	757 - 585 nm
purity factor	0.90 - 0.98

The transmission factor must be  $> 0.78$

The transmission factor shall be determined by using a light source with a colour temperature of 2,856 K.<sup>13/</sup>

- 7.2. The filter must be part of the headlamp, and must be attached to it in such a way that the user cannot remove it either inadvertently or, with ordinary tools, intentionally.

## 8. GAUGING OF DISCOMFORT

The discomfort caused by the passing beam of headlamps shall be gauged.<sup>14/</sup>

## 9. STANDARD (REFERENCE) HEADLAMP<sup>15/</sup>

A headlamp shall be deemed to be a standard (reference) headlamp if it

- 9.1. satisfies the above-mentioned requirements for approval;
- 9.2. has an effective diameter of not less than 160 mm;
- 9.3. provides, with a standard (reference) filament lamp, at the various points and in the various zones referred to in paragraph 6.2.5., illumination equal to:
- 9.3.1. not more than 90% of the maximum limits, and
- 9.3.2. not less than 120% of the minimum limits, prescribed in the table in paragraph 6.2.5.

## 10. OBSERVATION CONCERNING COLOUR

Since any approval under this Regulation is granted, pursuant to paragraph 7.1. above, for a type of headlamp emitting either white light or selective-yellow light, article 3 of the Agreement to which the Regulation is annexed shall not prevent the Contracting Parties from prohibiting headlamps emitting a beam of white or selective-yellow light on vehicles registered by them.

## C. FURTHER ADMINISTRATIVE PROVISIONS

### 11. MODIFICATION OF THE HEADLAMP TYPE AND EXTENSION OF APPROVAL

- 11.1. Every modification of the headlamp type shall be notified to the administrative department which approved the headlamp type. The said department may then either:

<sup>13/</sup> Corresponding to illumination A of the International Commission on Illumination (CIE).

<sup>14/</sup> This requirement will be the subject of a recommendation to administrations.

<sup>15/</sup> Different values may be accepted provisionally. In the absence of definitive specifications, the use of an approved headlamp is recommended.

- 11.1.1. Consider that the modifications made are unlikely to have appreciable adverse effects and that in any event the headlamp still complies with the requirements; or
- 11.1.2. Require a further test report from the technical service responsible for conducting the tests.
- 11.2. Confirmation or refusal of approval, specifying the alterations, shall be communicated by the procedure specified in paragraph 4.1.4. above to the Parties to the Agreement which apply this Regulation.
- 11.3. The competent authority issuing the extension of approval shall assign a series number to each communication form drawn up for such an extension and inform thereof the other Parties to the 1958 Agreement applying this Regulation by means of a communication form conforming to the model in annex 1 to this Regulation.

## **12. CONFORMITY OF PRODUCTION**

- 12.1 Headlamps approved under this Regulation shall be so manufactured as to conform to the type approved by meeting the requirements set forth in paragraphs 6 and 7.
- 12.2. In order to verify that the requirements of paragraph 12.1. are met, suitable controls of the production shall be carried out.
- 12.3. The holder of the approval shall in particular:
  - 12.3.1. ensure the existence of procedures for the effective control of the quality of products;
  - 12.3.2. have access to the control equipment necessary for checking the conformity to each approved type;
  - 12.3.3. ensure that data of test results are recorded and that related documents shall remain available for a period to be determined in accordance with the administrative service;
  - 12.3.4. analyze the results of each type of test in order to verify and ensure the stability of the product characteristics making allowance for variation of an industrial production;
  - 12.3.5. ensure that for each type of product at least the tests prescribed in Annex 5 to this Regulation are carried out;
  - 12.3.6. ensure that any collecting of samples giving evidence of non-conformity with the type of test considered shall give rise to another sampling and another test. All the necessary steps shall be taken to re-establish the conformity of the corresponding production.
- 12.4. The competent authority which has granted type approval may at any time verify the conformity control methods applicable to each production unit.
  - 12.4.1. In every inspection, the test books and production survey records shall be presented to the visiting inspector.
  - 12.4.2. The inspector may take samples at random to be tested in the manufacturer's laboratory. The minimum number of samples may be determined in the light of the results of the manufacturer's own checks.

- 12.4.3. When the quality level appears unsatisfactory or when it seems necessary to verify the validity of the tests carried out in the application of paragraph 12.4.2. above, the inspector shall select samples, to be sent to the technical service which has conducted the type approval tests, using the criteria of Annex 7.
- 12.4.4. The competent authority may carry out any test prescribed in this Regulation. These tests will be on samples selected at random without causing distortion of the manufacturer's delivery commitments and in accordance with the criteria of Annex 7.
- 12.4.5. The competent authority shall strive to obtain a frequency of inspection of once every two years. However, this is at the discretion of the competent authority and their confidence in the arrangements for ensuring effective control of the conformity of production. In the case where negative results are recorded, the competent authority shall ensure that all necessary steps are taken to re-establish the conformity of production as rapidly as possible.
- 12.5. Headlamps with apparent defects are disregarded.
- 12.6. The reference mark is disregarded.

### **13. PENALTIES FOR NON-CONFORMITY OF PRODUCTION**

- 13.1. The approval granted in respect of a type of headlamp pursuant to this Regulation may be withdrawn if the requirements are not complied with or if a headlamp bearing the approval mark does not conform to the type approved.
- 13.2. If a Contracting Party to the Agreement applying this Regulation withdraws an approval it has previously granted, it shall forthwith so notify the other Contracting Parties applying this Regulation by means of a communication form conforming to the model in annex 1 to this Regulation.

### **14. PRODUCTION DEFINITELY DISCONTINUED**

If the holder of the approval completely ceases to manufacture a type of headlamp approved in accordance with this Regulation, he shall so inform the authority which granted the approval. Upon receiving the relevant communication, that authority shall inform thereof the other Parties to the 1958 Agreement applying this Regulation by means of a communication form conforming to the model in annex 1 to this Regulation.

### **15. NAMES AND ADDRESSES OF TECHNICAL SERVICES RESPONSIBLE FOR CONDUCTING APPROVAL TESTS, AND OF ADMINISTRATIVE DEPARTMENTS**

The Parties to the 1958 Agreement applying this Regulation shall communicate to the United Nations Secretariat the names and addresses of the technical services responsible for conducting approval tests and of the administrative departments which grant approval and to which forms certifying approval or extension or refusal or withdrawal of approval, or production definitely discontinued, issued in other countries, are to be sent.

**Annex 1**

COMMUNICATION

(Maximum format: A4 (210 x 297 mm))

issued by: Name of administration



concerning:<sup>2/</sup> APPROVAL GRANTED  
APPROVAL EXTENDED  
APPROVAL REFUSED  
APPROVAL WITHDRAWN  
PRODUCTION DEFINITELY DISCONTINUED

of a type of headlamp pursuant to Regulation No. 1

Approval No.

Extension No.

1. Trade name or mark of the device:
2. Manufacturer's name for the type of device:
3. Manufacturer's name and address:
4. If applicable, name and address of the manufacturer's representative:
5. Submitted for approval on:
6. Technical service responsible for conducting approval tests:
7. Date of test report:
8. Number of test report:
9. Brief description:  
Category as described by the relevant marking:<sup>3/</sup>  
Colour of light emitted: white/selective yellow<sup>2/</sup>
10. Position of the approval mark:

<sup>1/</sup> Distinguishing number of the country which has granted/extended/refused/withdrawn approval (see approval provisions in the Regulation).

<sup>2/</sup> Strike out what does not apply.

<sup>3/</sup> Indicate the appropriate marking selected from the list below:

CR, CR, CR, C/R, C/R, C/R, C, C, C, C/, C/, C/R, CR PL, CR PL, CR PL,  
→ ↔ → ↔ → ↔ → ↔ → ↔  
C/R PL, C/R PL, C/R PL, C PL, C PL, C PL, C/PL, C/PL, C/PL, RPL  
→ ↔ → ↔ → ↔ → ↔ → ↔

11. Reason(s) for extension (if applicable):
12. Approval granted/refused/extended/withdrawn <sup>2/</sup>
13. Place:
14. Date:
15. Signature:
16. The list of documents deposited with the Administrative Service which has granted approval is annexed to this communication and may be obtained on request.

Annex 2

EXAMPLES OF ARRANGEMENTS OF APPROVAL MARKS

1.

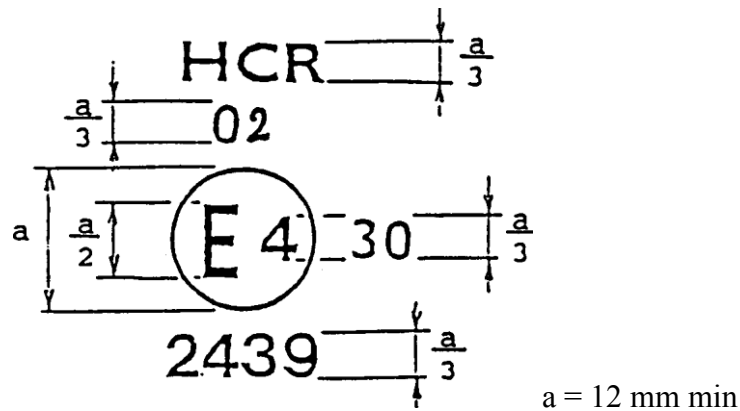

Figure 1

The headlamp bearing the approval marking shown above is a head lamp approved in the Netherlands (E4), under approval number 2439, meeting the requirements of this Regulation, as amended by the 02 series of amendments (02), in respect of both the driving beam and the passing beam (HCR) and which is designed for right-hand traffic only.

The figure 30 indicates that the maximum intensity of the driving beam is between 86,250 and 101,250 candelas.

Note: The approval number and the additional symbols shall be placed close to the circle and either above or below the letter 'E', or to the right or left of that letter. The digits of the approval number shall be on the same side of the letter 'E' and face the same direction.

The use of Roman numerals as approval numbers should be avoided so as to prevent any confusion with other symbols.

2.

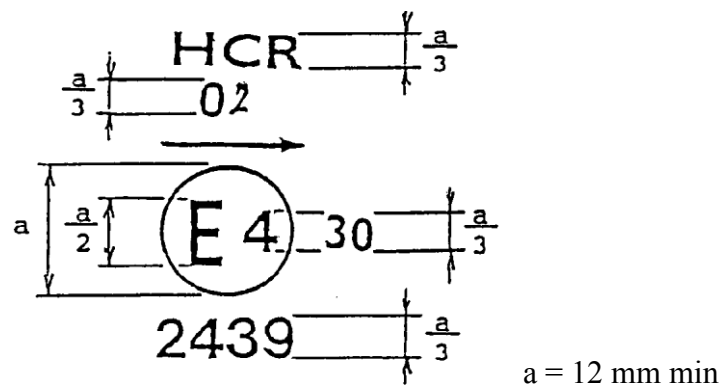

Figure 2

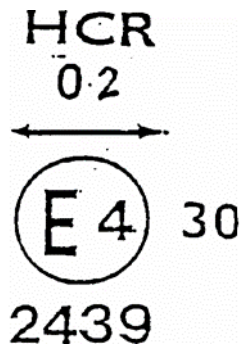

Figure 3a

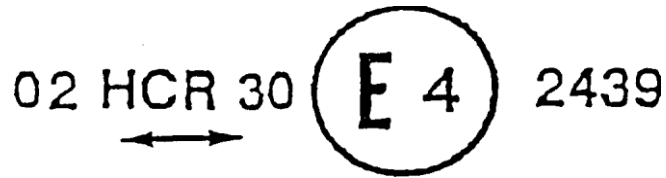

Figure 3b

The headlamp bearing the approval marking shown above is a headlamp meeting the requirements of this Regulation with respect to both the passing beam and the driving beam and designed:

Figure 2 = For left-hand traffic only.

Figure 3a, 3b = For both traffic systems, by means of an adjustment as desired of the setting of the optical unit or the filament lamp.

3.

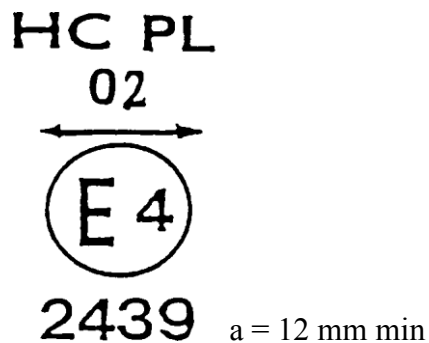

Figure 4

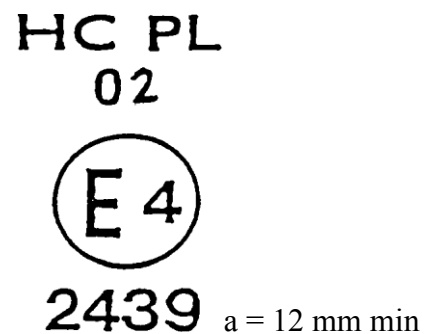

Figure 5

The headlamp bearing the approval mark shown above is a headlamp incorporating the lens of plastic material meeting the requirements of this Regulation with respect to the passing beam only, and designed:

Figure 4 = For both traffic systems.

Figure 5 = For right-hand traffic only.

4.

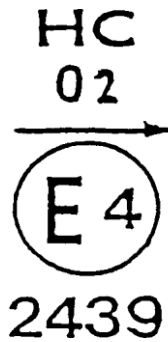

Figure 6

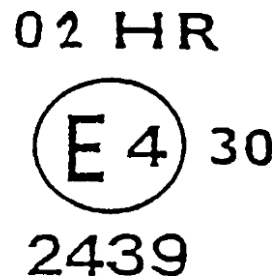

Figure 7

The headlamp bearing the approval mark shown above is a headlamp meeting the requirements of this Regulation:

Figure 6 = With respect to the passing beam only, and designed for left-hand traffic only. Figure 7 = With respect to the driving beam only.

5.

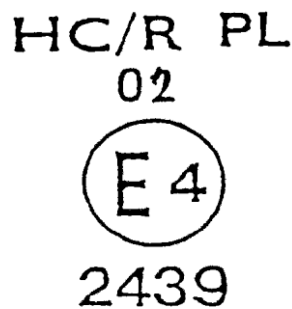

Figure 8

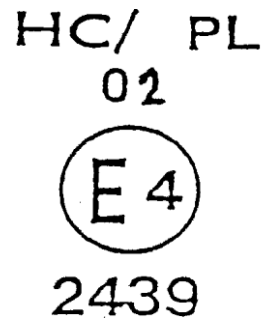

Figure 9

Identification of a headlamp incorporating the lens of plastic material meeting the requirements of Regulation No. 20:

Figure 8 = For both the passing beam and the driving beam and designed for right-hand traffic only.

Figure 9 = For the passing beam only and designed for left-hand traffic only.

The passing lamp filament shall not be lit simultaneously with the driving lamp filament and/or any other headlamp with which it is reciprocally incorporated.

**6. Simplified marking for grouped, combined or reciprocally incorporated lamps**

**Figure 10**

(The vertical and horizontal lines schematize the shape of the light-signalling device. They are not part of the approval mark).

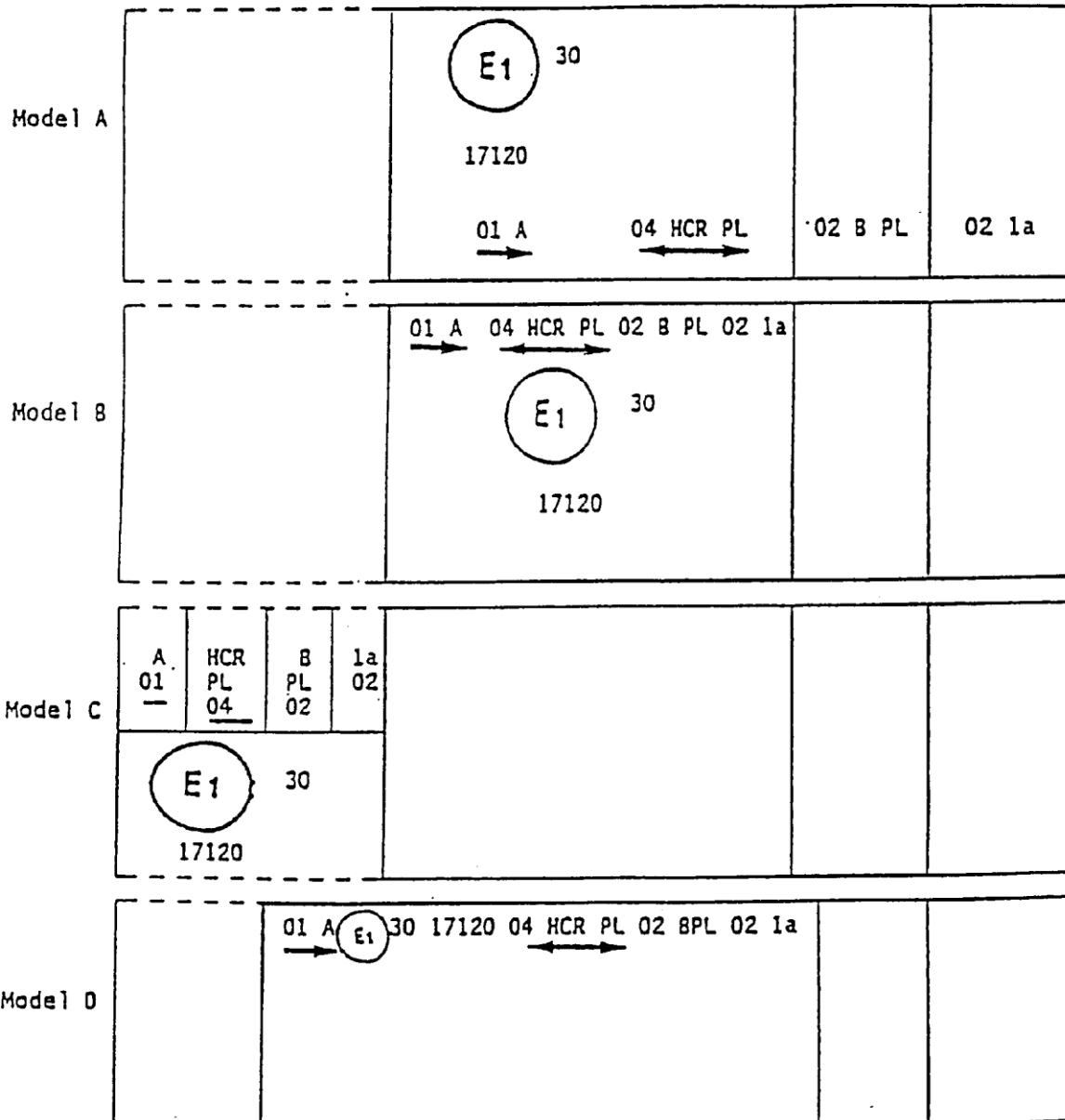

NOTE:

The four examples shown above correspond to a lighting device bearing an approval mark relating to:

A front position lamp approved in accordance with the 01 series of amendments to Regulation No. 7;

A headlamp with a passing beam designed for right-hand and left-hand traffic and a driving beam with a maximum intensity comprised between 86,250 and 101,250 candelas (as indicated by the number 30), approved in accordance with the 02

series of amendments to Regulation No. 20 and incorporating a lens of plastic material;

A front fog lamp approved in accordance with the 02 series of amendments to Regulation No. 19 and incorporating a lens of plastic material;

A front direction indicator lamp of category 1a approved in accordance with the 02 series of amendments to Regulation No. 6.

7. **Lamp reciprocally incorporated with a headlamp**

**Figure 11**

Example 1

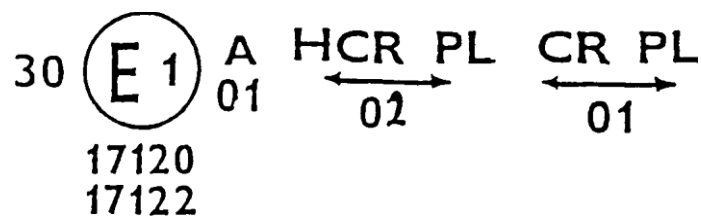

The above example corresponds to the marking of a lens of plastic material intended to be used in different types of headlamps, namely:

either: a headlamp with a passing beam designed for right-hand and left-hand traffic and a driving beam with a maximum intensity comprised between 86,250 and 101,250 candelas, approved in Germany (E1) in accordance with the requirements of Regulation No. 20 as amended by the 02 series of amendments, which is reciprocally incorporated with a front position lamp approved in accordance with the 01 series of amendments to Regulation No. 7;

or: a headlamp with a passing beam designed for right-hand and left-hand traffic and a driving beam, approved in Germany (E1) in accordance with the requirements of Regulation No. 1 as amended by the 01 series of amendments, which is reciprocally incorporated with the same front position lamp as above;

or even: either of the above-mentioned headlamps approved as a single lamp.

The main body of the headlamp shall bear the only valid approval number, for instance:

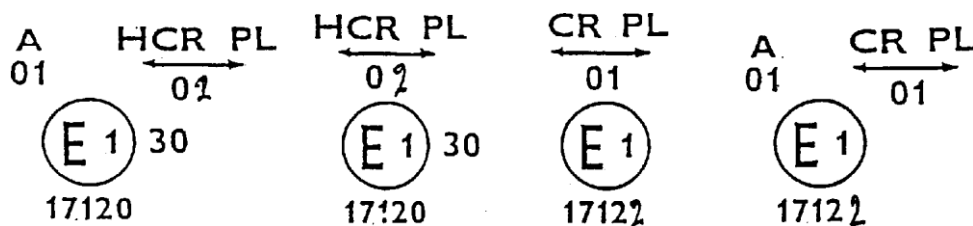



Annex 3

MEASURING SCREEN

A. Headlamp for right-hand traffic (Dimensions in mm)

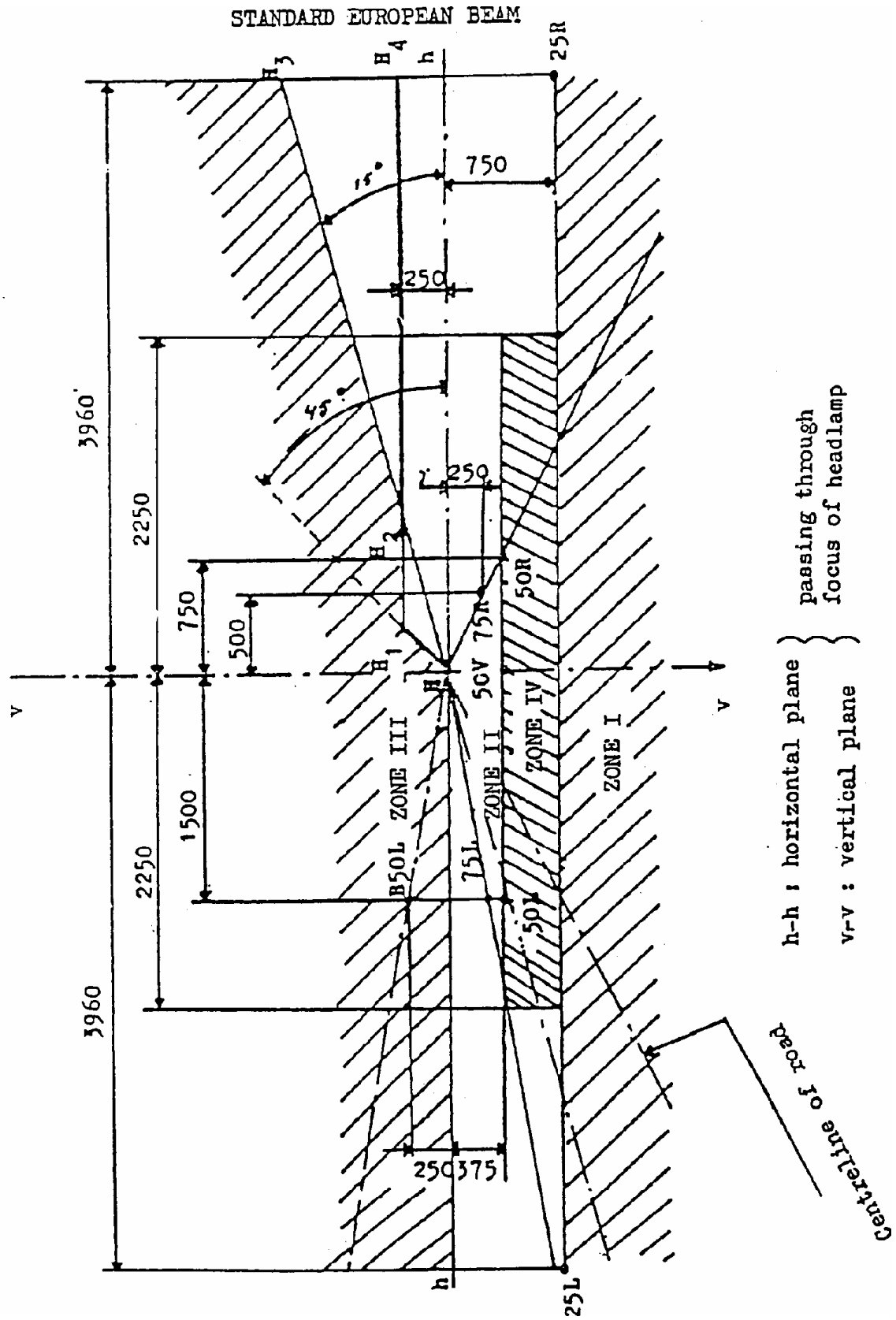

**B. Headlamp for left-hand traffic** (Dimensions in mm)

STANDARD EUROPEAN BEAM

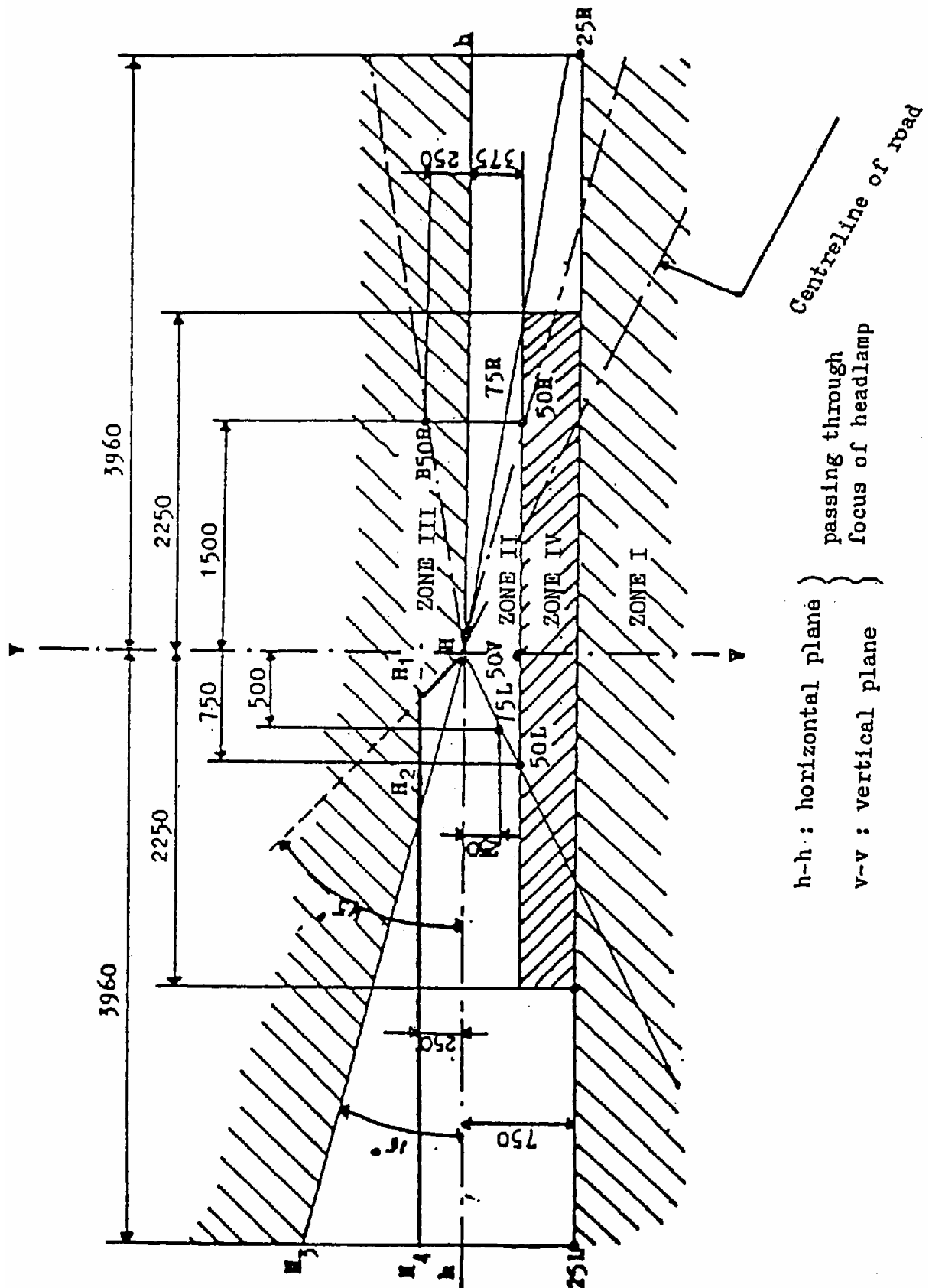

h-h : horizontal plane }  
 passing through }  
 focus of headlamp }  
 v-v : vertical plane }

Centreline of road

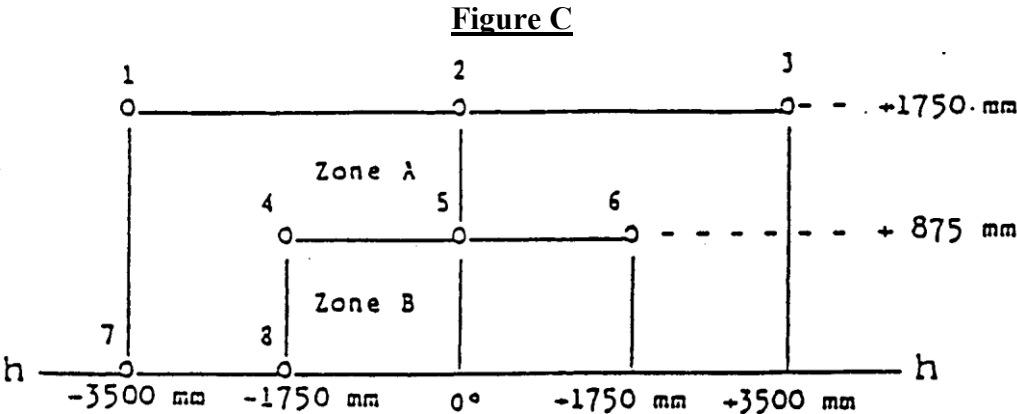

Note:

Figure C shows the measuring points for right-hand traffic.  
Points 7 and 8 move to their corresponding location at the right-hand side of the picture for left-hand traffic.

## Annex 4

### TESTS FOR STABILITY OF PHOTOMETRIC PERFORMANCE OF HEADLAMPS IN OPERATION

#### TESTS ON COMPLETE HEADLAMPS

Once the photometric values have been measured according to the prescriptions of this Regulation, in the point for  $E_{\max}$  for driving beam and in points HV, 50 R, B 50 L for passing beam (or HV, 50 L, B 50 R for headlamps designed for left-hand traffic) a complete headlamp sample shall be tested for stability of photometric performance in operation. "Complete headlamp" shall be understood to mean the complete lamp itself including those surrounding body parts and lamps which could influence its thermal dissipation.

#### 1. TEST FOR STABILITY OF PHOTOMETRIC PERFORMANCE

The tests shall be carried out in a dry and still atmosphere at an ambient temperature of 23 degrees C +/- 5 degrees C, the complete headlamp being mounted on a base representing the correct installation on the vehicle.

##### 1.1. Clean headlamp

The headlamp shall be operated for 12 hours as described in subparagraph 1.1.1. and checked as prescribed in subparagraph 1.1.2.

##### 1.1.1. Test procedure

The headlamp shall be operated for a period according to the specified time, so that:

- 1.1.1.1. (a) In the case where only one lighting function (driving or passing beam) is to be approved, the corresponding filament is lit for the prescribed time,<sup>2/</sup>
- (b) In the case of a reciprocally incorporated passing lamp and driving lamp (dual filament lamp or two filament lamps):

If the applicant declares that the headlamp is to be used with a single filament lit<sup>1/</sup> at a time, the test shall be carried out in accordance with this condition, activating<sup>2/</sup> each specified function successively for half the time specified in paragraph 1.1.;

In all other cases,<sup>1/ 2/</sup> the headlamp shall be subjected to the following cycle until the time specified is reached:

15 minutes, passing-beam filament lit

5 minutes, all filaments lit;

- (c) In the case of grouped lighting functions all the individual functions shall be lit simultaneously for the time specified for individual lighting functions (a), also taking into account the use of reciprocally incorporated lighting functions (b), according to the manufacturer's specifications.

---

<sup>2/</sup> When the tested headlamp is grouped and/or reciprocally incorporated with signalling lamps, the latter shall be lit for the duration of the test. In the case of a direction indicator lamp, it shall be lit in flashing operation mode with an on/off time ratio of approximately one to one.

<sup>1/</sup> Should two or more lamp filaments be simultaneously lit when headlamp flashing is used, this shall not be considered as being normal use of the filaments simultaneously.

1.1.1.2. Test voltage

The voltage shall be adjusted so as to supply 90 % of the maximum wattage specified in the Regulation for filament lamps (Regulation No. 37).

The applied wattage shall in all cases comply with the corresponding value of a filament lamp of 12 V rated voltage, except if the applicant for approval specifies that the headlamp may be used at a different voltage. In the latter case, the test shall be carried out with the filament lamp whose wattage is the highest that can be used.

1.1.2. Test results

1.1.2.1. Visual inspection

Once the headlamp has been stabilized to the ambient temperature, the headlamp lens and the external lens, if any, shall be cleaned with a clean, damp cotton cloth. It shall then be inspected visually; no distortion, deformation, cracking or change in colour of either the headlamp lens or the external lens, if any, shall be noticeable.

1.1.2.2. Photometric test

To comply with the requirements of this Regulation, the photometric values shall be verified in the following points:

Passing beam:

50 R - B 50 L - HV for headlamps designed for right-hand traffic,

50 L - B 50 R - HV for headlamps designed for left-hand traffic.

Driving beam

Point of  $E_{\max}$

Another aiming may be carried out to allow for any deformation of the headlamp base due to heat (the change of the position of the cut-off line is covered in paragraph 2 of this annex).

A 10 % discrepancy between the photometric characteristics and the values measured prior to the test is permissible including the tolerances of the photometric procedure.

1.2. Dirty headlamp

After being tested as specified in subparagraph 1.1. above, the headlamp shall be operated for one hour as described in subparagraph 1.1.1., after being prepared as prescribed in subparagraph 1.2.1., and checked as prescribed in subparagraph 1.1.2.

1.2.1. Preparation of the headlamp

1.2.1.1. Test mixture

1.2.1.1.1. For headlamp with the outside lens in glass:

The mixture of water and a polluting agent to be applied to the headlamp shall be composed of:

9 parts by weight of silica sand with a particle size of 0-100  $\mu\text{m}$ ,

1 part by weight of vegetal carbon dust (beechwood) with a particle size of 0-100  $\mu\text{m}$ , 0.2 parts by weight of NaCMC<sup>3/</sup>, and  
an appropriate quantity of distilled water, with a conductivity of < 1 mS/m.

The mixture must not be more than 14 days old.

1.2.1.1.2. For headlamp with outside lens in plastic material:

The mixture of water and polluting agent to be applied to the headlamp shall be composed of:

9 parts by weight of silica sand with a particle size of 0-100  $\mu\text{m}$ ,  
part by weight of vegetal carbon dust (beechwood) with a particle size of 0-100  $\mu\text{m}$ , 0.2 part by weight of NaCMC<sup>3/</sup>,  
13 parts by weight of distilled water with a conductivity of < 1 mS/m, and 2 +/- 1 parts by weight of surface-actant<sup>4/</sup>.

The mixture must not be more than 14 days old.

1.2.1.2. Application of the test mixture to the headlamp

The test mixture shall be uniformly applied to the entire light-emitting surface of the headlamp and then left to dry. This procedure shall be repeated until the illumination value has dropped to 15-20% of the values measured for each following point under the conditions described in this annex:

Point of  $E_{\text{max}}$  in passing beam/driving beam and in driving beam only,  
50 R and 50 V<sup>5/</sup> for a passing lamp only, designed for right-hand traffic, 50 L and 50 V<sup>5/</sup> for a passing lamp only, designed for left-hand traffic.

1.2.1.3. Measuring equipment

The measuring equipment shall be equivalent to that used during headlamp approval tests. A standard (reference) filament lamp shall be used for the photometric verification.

**2. TEST FOR CHANGE IN VERTICAL POSITION OF THE CUT-OFF LINE UNDER THE INFLUENCE OF HEAT**

This test consists of verifying that the vertical drift of the cut-off line under the influence of heat does not exceed a specified value for an operating passing lamp.

The headlamp tested in accordance with paragraph 1, shall be subjected to the test described in 2.1., without being removed from or readjusted in relation to its test fixture.

---

<sup>3/</sup> NaCMC represents the sodium salt of carboxymethylcellulose, customarily referred to as CMC. The NaCMC used in the dirt mixture shall have a degree of substitution (DS) of 0.6-0.7 and a viscosity of 200-300 cP for a 2% solution at 20 degrees C.

<sup>4/</sup> The tolerance on quantity is due to the necessity of obtaining a dirt that correctly spreads out on all the plastic lens.

<sup>5/</sup> The tolerance on quantity is due to the necessity of obtaining a dirt that correctly spreads out on all the plastic lens.

2.1. Test

The test shall be carried out in a dry and still atmosphere at an ambient temperature of 23 degrees C +/- 5 degrees C.

Using a mass production filament lamp which has been aged for at least one hour the headlamp shall be operated on passing beam without being dismantled from or readjusted in relation to its test fixture. (For the purpose of this test, the voltage shall be adjusted as specified in paragraph 1.1.1.2.). The position of the cut-off line in its horizontal part (between vv and the vertical line passing through point B 50 L for right-hand traffic or B 50 R for left-hand traffic) shall be verified 3 minutes (r3) and 60 minutes (r60) respectively after operation.

The measurement of the variation in the cut-off line position as described above shall be carried out by any method giving acceptable accuracy and reproducible results.

2.2. Test results

2.2.1. The result in milliradians (mrad) shall be considered as acceptable for a passing lamp, only when the absolute value

$\Delta rI = |r3 - r60|$  recorded on the headlamp is not more than 1.0 mrad ( $\Delta rI < 1.0$  mrad).

2.2.2. However, if this value is more than 1.0 mrad but not more than 1.5 mrad ( $1.0 \text{ mrad} < \Delta rI < 1.5 \text{ mrad}$ ) a second headlamp shall be tested as described in paragraph 2.1. after being subjected three consecutive times to the cycle as described below, in order to stabilize the position of mechanical parts of the headlamp on a base representative of the correct installation on the vehicle:

Operation of the passing beam for one hour, (the voltage shall be adjusted as specified in paragraph 1.1.1.2.),

Period of rest for one hour.

The headlamp type shall be considered as acceptable if the mean value of the absolute values  $\Delta rI$  measured on the first sample and  $\Delta rII$  measured on the second sample is not more than 1.0 mrad.

$$\frac{\Delta rI + \Delta rII}{2} \leq 1 \text{ mrad}$$

## Annex 5

### MINIMUM REQUIREMENTS FOR CONFORMITY OF PRODUCTION CONTROL PROCEDURES

#### 1. GENERAL

- 1.1. The conformity requirements shall be considered satisfied from a mechanical and geometric standpoint, if the differences do not exceed inevitable manufacturing deviations within the requirements of this Regulation.
- 1.2. With respect to photometric performances, the conformity of mass-produced headlamps shall not be contested if, when testing photometric performances of any headlamp chosen at random and equipped with a standard filament lamp:
- 1.2.1. no measured value deviates unfavourably by more than 20 % from the values prescribed in this Regulation. For values B 50 L (or R) and zone III, the maximum unfavourable deviation may be respectively:
- |                |                               |
|----------------|-------------------------------|
| B 50 L (or R): | 0.2 lambda x equivalent 20 %  |
|                | 0.3 lambda x equivalent 30 %  |
| Zone III:      | 0.3 lambda x equivalent 20 %  |
|                | 0.45 lambda x equivalent 30 % |
- 1.2.2. or if
- 1.2.2.1. for the passing beam, the values prescribed in this Regulation are met at HV (with a tolerance of + 0.2 lambda x) and related to that aiming at least one point of each area delimited on the measuring screen (at 25 m) by a circle 15 cm in radius around points B 50 L (or R)<sup>1/</sup> (with a tolerance of + 0.1 l x), 75 R (or L), 50 V, 25 R, 25 L, and in the entire area of zone IV which is not more than 22.5 cm above line 25 R and 25 L;
- 1.2.2.2. and if, for the driving beam, HV being situated within the isolux 0.75 E<sub>max</sub>, a tolerance of + 20 % for maximum values and -20 % for minimum values is observed for the photometric values at any measuring point specified in paragraph 6.3.2. of this Regulation.
- 1.2.3. If the results of the tests described above do not meet the requirements, the alignment of the headlamp may be changed, provided that the axis of the beam is not displaced laterally by more than 1 degrees to the right or left.<sup>13/</sup>
- 1.2.4. If the results of the tests described above do not meet the requirements, tests on the headlamp shall be repeated using another standard filament lamp.
- 1.3. With respect to the verification of the change in vertical position of the cut-off line under the influence of heat, the following procedure shall be applied:
- One of the sampled headlamps shall be tested according to the procedure described in paragraph 2.1. of Annex 4 after being subjected three consecutive times to the cycle described in paragraph 2.2.2. of Annex 4.
- The headlamp shall be considered as acceptable if Dr does not exceed 1.5 mrad.

<sup>1/</sup> Letters in brackets refer to headlamps intended for left-hand traffic.

<sup>13/</sup> See the corresponding footnote in the text of the Regulation.

If this value exceeds 1.5 mrad but is not more than 2.0 mrad, a second headlamp shall be subjected to the test after which the mean of the absolute values recorded on both samples shall not exceed 1.5 mrad.

- 1.4. The chromaticity coordinates shall be complied with when the headlamp is equipped with a filament lamp set to Standard A colour temperature.

The photometric performance of a headlamp emitting selective yellow light when equipped with a colourless filament lamp shall be the values contained in this Regulation multiplied by 0.84.

## **2. MINIMUM REQUIREMENTS FOR VERIFICATION OF CONFORMITY BY THE MANUFACTURER**

For each type of headlamp the holder of the approval mark shall carry out at least the following tests, at appropriate intervals. The tests shall be carried out in accordance with the provisions of this Regulation.

If any sampling shows non-conformity with regard to the type of test concerned, further samples shall be taken and tested. The manufacturer shall take steps to ensure the conformity of the production concerned.

### **2.1. Nature of tests**

Tests of conformity in this Regulation shall cover the photometric characteristics and the verification of the change in vertical position of the cut-off line under the influence of heat.

### **2.2. Methods used in tests**

- 2.2.1. Tests shall generally be carried out in accordance with the methods set out in this Regulation.

- 2.2.2. In any test of conformity carried out by the manufacturer, equivalent methods may be used with the consent of the competent authority responsible for approval tests. The manufacturer is responsible for proving that the applied methods are equivalent to those laid down in this Regulation.

- 2.2.3. The application of paragraphs 2.2.1. and 2.2.2. requires regular calibration of test apparatus and its correlation with measurements made by a competent authority.

- 2.2.4. In all cases the reference methods shall be those of this Regulation, particularly for the purpose of administrative verification and sampling.

### **2.3. Nature of sampling**

Samples of headlamps shall be selected at random from the production of a uniform batch. A uniform batch means a set of headlamps of the same type, defined according to the production methods of the manufacturer.

The assessment shall in general cover series production from individual factories. However, a manufacturer may group together records concerning the same type from several factories, provided these operate under the same quality system and quality management.

### **2.4. Measured and recorded photometric characteristics**

The sampled headlamp shall be subjected to photometric measurements at the points provided for in the Regulation, the reading being limited to points  $E_{max}$ ,

HV<sup>1/</sup>, HL, HR<sup>2/</sup> in the case of the driving beam, and to points B 50 L (or R), HV, 50 V, 75 R (or L) and 25 L (or R) in the case of the passing beam (see figure in Annex 3).

## 2.5. Criteria governing acceptability

The manufacturer is responsible for carrying out a statistical study of the test results and for defining, in agreement with the competent authority, criteria governing the acceptability of his products in order to meet the specifications laid down for verification of conformity of products in paragraph 12.1. of this Regulation.

The criteria governing the acceptability shall be such that, with a confidence level of 95 %, the minimum probability of passing a spot check in accordance with Annex 7 (first sampling) would be 0.95.

---

<sup>1/</sup> When the driving beam is reciprocally incorporated with the passing beam, HV in the case of the driving beam shall be the same measuring point as in the case of the passing beam.

<sup>2/</sup> HL and HR: points on "hh" located at 1.125 m to the left and to the right of point HV respectively.

## Annex 6

### REQUIREMENTS FOR LAMPS INCORPORATING LENSES OF PLASTIC MATERIAL- TESTING OF LENS OR MATERIAL SAMPLES AND OF COMPLETE LAMPS

#### 1. GENERAL SPECIFICATIONS

- 1.1. The samples supplied pursuant to paragraph 2.2.4. of this Regulation shall satisfy the specifications indicated in paragraphs 2.1. to 2.5. below.
- 1.2. The two samples of complete lamps supplied pursuant to paragraph 2.2.3. of this Regulation and incorporating lenses of plastic material shall, with regard to the lens material, satisfy the specifications indicated in paragraph 2.6. below.
- 1.3. The samples of lenses of plastic material or samples of material shall be subjected, with the reflector to which they are intended to be fitted (where applicable), to approval tests in the chronological order indicated in table A reproduced in appendix 1 to this annex.
- 1.4. However, if the lamp manufacturer can prove that the product has already passed the tests prescribed in paragraphs 2.1.-2.5. below, or the equivalent tests pursuant to another Regulation, those tests need no be repeated; only the tests prescribed in appendix 1, table B, shall be mandatory.

#### 2. TESTS

##### 2.1. Resistance to temperature changes

##### 2.1.1. Tests

Three new samples (lenses) shall be subjected to five cycles of temperature and humidity (RH = relative humidity) change in accordance with the following programme: 3 hours at 40degrees C +/- 2degrees C and 85-95% RH;

1 hour at 23degrees C +/- 5degrees C and 60-75% RH;

15 hours at -30degrees C +/- 2degrees C;

1 hour at 23degrees C +/- 5degrees C and 60-75% RH;

3 hours at 80degrees C +/- 2degrees C;

1 hour at 23degrees C +/- 5degrees C and 60-75% RH;

Before this test, the samples shall be kept at 23degrees C +/- 5degrees C and 60-75% RH for at least four hours.

Note: The periods of one hour at 23 degrees C +/- 5degrees C shall include the periods of transition from one temperature to another which are needed in order to avoid thermal shock effects.

##### 2.1.2. Photometric measurements

##### 2.1.2.1. Method

Photometric measurements shall be carried out on the samples before and after the test. These measurements shall be made using a standard lamp, at the following points:

B 50 L and 50 R for the passing beam of a passing lamp or a passing/driving lamp (B 50 R and 50 L in the case of headlamps intended for left-hand traffic);

2.1.2.2. Results

The variation between the photometric values measured on each sample before and after the test shall not exceed 10% including the tolerances of the photometric procedure.

2.2. Resistance to atmospheric and chemical agents

2.2.1. Resistance to atmospheric agents

Three new samples (lenses or samples of material) shall be exposed to radiation from a source having a spectral energy distribution similar to that of a black body at a temperature between 5,500K and 6,000K. Appropriate filters shall be placed between the source and the samples so as to reduce as far as possible radiations with wave lengths smaller than 295 nm and greater than 2,500 nm. The samples shall be exposed to an energetic illumination of 1,200 W/m<sup>2</sup> +/- 200 W/m<sup>2</sup> for a period such that the luminous energy that they receive is equal to 4,500 MJ/m<sup>2</sup> +/- 200 MJ/m<sup>2</sup>. Within the enclosure, the temperature measured on the black panel placed on a level with the samples shall be 50 degrees C +/- 5 degrees C. In order to ensure a regular exposure, the samples shall revolve around the source of radiation at a speed between 1 and 5 1/min.

The samples shall be sprayed with distilled water of conductivity lower than 1 mS/m at a temperature of 23 degrees C +/- 5 degrees C, in accordance with the following cycle:

spraying: 5 minutes;

drying: 25 minutes;

2.2.2. Resistance to chemical agents

After the test described in paragraph 2.2.1. above and the measurement described in paragraph 2.2.3.1. below have been carried out, the outer face of the said three samples shall be treated as described in paragraph 2.2.2.2. with the mixture defined in paragraph 2.2.2.1. below.

2.2.2.1. Test mixture

The test mixture shall be composed of 61.5% n-heptane, 12.5% toluene, 7.5% ethyl tetrachloride, 12.5% trichloroethylene and 6% xylene (volume %).

2.2.2.2. Application of the test mixture

Soak a piece of cotton cloth (as per ISO 105) until saturation with the mixture defined in paragraph 2.2.2.1. above and, within 10 seconds, apply it for 10 minutes to the outer face of the sample at a pressure of 50 N/cm<sup>2</sup>, corresponding to an effort of 100 N applied on a test surface of 14 x 14 mm.

During the period of application, it is permissible to compensate the pressure applied to the sample in order to prevent it from causing cracks.

### 2.2.2.3. Cleaning

At the end of the application of the test mixture, the samples shall be dried in the open air and then washed with the solution described in paragraph 2.3.

(Resistance to detergents) 23 degrees C +/- 5 degrees C.

Afterwards the samples shall be carefully rinsed with distilled water containing not more than 0.2% impurities at 23 degrees C +/- 5 degrees C and then wiped off with a soft cloth.

### 2.2.3. Results

2.2.3.1. After the test of resistance to atmospheric agents, the outer face of the samples shall be free from cracks, scratches, chipping and deformation, and the mean variation in transmission

$$\Delta t = \frac{T2 - T3}{T2}$$

measured on the three samples according to the procedure described in appendix 2 to this annex shall not exceed 0.020 ( $\Delta t_m < 0.020$ ).

2.2.3.2. After the test of resistance to chemical agents, the samples shall not bear any traces of chemical staining likely to cause a variation of flux diffusion, whose mean variation

$$\Delta d = \frac{T5 - T4}{T2} \Big|$$

measured on the three samples according to the procedure described in appendix 2 to this annex shall not exceed 0.020 ( $\Delta d_m < 0.020$ ).

## 2.3. Resistance to detergents and hydrocarbons

### 2.3.1. Resistance to detergents

The outer face of three samples (lenses or samples of material) shall be heated to 50 degrees C +/- 5 degrees C and then immersed for five minutes in a mixture maintained at 23 degrees C +/- 5 degrees C and composed of 99 parts distilled water containing not more than 0.02% impurities and one part alkylaryl sulphonate.

At the end of the test, the samples shall be dried at 50 degrees C +/- 5 degrees C. The surface of the samples shall be cleaned with a moist cloth.

### 2.3.2. Resistance to hydrocarbons

The outer face of these three samples shall then be lightly rubbed for one minute with a cotton cloth soaked in a mixture composed of 70% n-heptane and 30% toluene (volume %), and shall then be dried in the open air.

### 2.3.3. Results

After the above two tests have been performed successively, the mean value of the variation in transmission

$$\Delta t = \frac{T2 - T3}{T2} \Big|$$

measured on the three samples according to the procedure described in appendix 2 to this annex shall not exceed 0.010 ( $\Delta t_m < 0.010$ ).

2.4. Resistance to mechanical deterioration

2.4.1. Mechanical deterioration method

The outer face of the three new samples (lenses) shall be subjected to the uniform mechanical deterioration test by the method described in appendix 3 to this annex.

2.4.2. Results

After this test, the variations: in transmission:

$$\Delta t = \frac{T2 - T3}{T2}$$

and in diffusion:

$$\Delta d = \frac{T5 - T4}{T2}$$

shall be measured according to the procedure described in appendix 2 in the area specified in paragraph 2.2.4.1.1. of this Regulation. The mean value of the three samples shall be such that:  $\Delta t_m < 0.100$ ;

$$\Delta d_m < 0.050.$$

2.5. Test of adherence of coatings, if any

2.5.1. Preparation of the sample

A surface of 20 mm x 20 mm in area of the coating of a lens shall be cut with a razor blade or a needle into a grid of squares approximately 2 mm x 2 mm. The pressure on the blade or needle shall be sufficient to cut at least the coating.

2.5.2. Description of the test

Use an adhesive tape with a force adhesion of 2 N/(cm of width) +/- 20% measured under the standardized conditions specified in appendix 4 to this annex. This adhesive tape, which shall be at least 25 mm wide, shall be pressed for at least five minutes to the surface prepared as prescribed in paragraph 2.5.1.

Then the end of the adhesive tape shall be loaded in such a way that the force of adhesion to the surface considered is balanced by a force perpendicular to that surface. At this stage, the tape shall be torn off at a constant speed of 1.5 m/s +/- 0.2 m/s.

2.5.3. Results

There shall be no appreciable impairment of the gridded area. Impairments at the intersections between squares or at the edges of the cuts shall be permitted, provided that the impaired area does not exceed 15% of the gridded surface.

2.6. Tests of the complete headlamp incorporating a lens of plastic material

2.6.1. Resistance to mechanical deterioration of the lens surface

2.6.1.1. Tests

The lens of lamp sample No. 1 shall be subjected to the test described in paragraph 2.4.1. above.

2.6.1.2. Results

After the test, the results of photometric measurements carried out on the headlamp in accordance with this Regulation shall not exceed by more than 30% the maximum values prescribed at points B 50 L and HV and not be more than 10% below the minimum values prescribed at point 75 R (in the case of headlamps intended for left-hand traffic, the points to be considered are B 50 R, HV and 75 L).

2.6.2. Test of adherence of coatings, if any

The lens of lamp sample No. 2 shall be subjected to the test described in paragraph 2.5. above.

**3. VERIFICATION OF THE CONFORMITY OF PRODUCTION**

3.1. With regard to the materials used for the manufacture of lenses, the lamps of a series shall be recognized as complying with this Regulation if:

3.1.1. After the test for resistance to chemical agents and the test for resistance to detergents and hydrocarbons, the outer face of the samples exhibits no cracks, chipping or deformation visible to the naked eye (see paras. 2.2.2., 2.3.1. and 2.3.2.);

3.1.2. After the test described in paragraph 2.6.1.1., the photometric values at the points of measurement considered in paragraph 2.6.1.2. are within the limits prescribed for conformity of production by this Regulation.

3.2. If the test results fail to satisfy the requirements, the tests shall be repeated on another sample of headlamps selected at random.

**Annex 6 - Appendix 1**

**CHRONOLOGICAL ORDER OF APPROVAL TESTS**

**A. Tests on plastic materials (lenses or samples of material supplied pursuant to paragraph 2.2.4. of this Regulation)**

Tests	Sample	Lenses or samples of material							Lenses					
		1	2	3	4	5	6	7	8	9	10	11	12	13
1.1 Limited photometry (para. 2.1.2.)											x	x	x	
1.1.1. Temperature change (para. 2.1.1.)											x	x	x	
1.1.2. Limited photometry (para. 2.1.2.)											x	x	x	
1.2.1. Transmission measurement		x	x	x	x	x	x	x	x	x				
1.2.2. Diffusion measurement		x	x	x				x	x	x				
1.3. Atmospheric agents (para. 2.2.1.)		x	x	x										
1.3.1. Transmission measurement		x	x	x										
1.4. Chemicals agents (para. 2.2.2.)		x	x	x										
1.4.1. Diffusion measurement		x	x	x										
1.5. Detergents (para. 2.3.1.)					x	x	x							
1.6. Hydrocarbons (para. 2.3.2.)					x	x	x							
1.6.1. Transmission measurement					x	x	x							
1.7. Deterioration (para. 2.4.1.)								x	x	x				
1.7.1. Transmission measurement								x	x	x				
1.7.2. Diffusion measurement								x	x	x				
1.8 Adherence (para. 2.5.)														x

**B. Tests on complete lamps (supplied pursuant to paragraph 2.2.3. of this Regulation)**

Tests	Complete Headlamp Sample No.	
	1	2
2.1. Deterioration (para. 2.6.1.1.)	x	
2.2. Photometry (para. 2.6.1.2.)	x	x
2.3. Adherence (para. 2.6.2.)		

## Annex 6 - Appendix 2

### METHOD OF MEASUREMENT OF THE DIFFUSION AND TRANSMISSION OF LIGHT

#### 1. EQUIPMENT (see figure)

The beam of a collimator K with a half divergence  $\beta/2 = 17.4 \times 10^{-4}$  rd is limited by a diaphragm Dr with an opening of 6 mm against which the sample stand is placed.

A convergent achromatic lens L2, corrected for spherical aberrations, links the diaphragm Dr with the receiver R; the diameter of the lens L2 shall be such that it does not diaphragm the light diffused by the sample in a cone with a half top angle of  $\beta/2 = 14$  degrees. An annular diaphragm DD with angle  $\alpha/2 = 1$  degrees and  $\alpha_{\max}/2 = 12$  degrees is placed in an image focal plane of the lens L2.

The non-transparent central part of the diaphragm is necessary in order to eliminate the light arriving directly from the light source. It shall be possible to remove the central part of the diaphragm from the light beam in such a manner that it returns exactly to its original position.

The distance L2 DT and the focal length  $F2^{1/}$  of the lens L2 shall be so chosen that the image of DT completely covers the receiver R.

When the initial incident flux is referred to 1,000 units, the absolute precision of each reading shall be better than 1 unit.

#### 2. MEASUREMENTS

The following readings shall be taken:

Reading	With sample	With central part of DD	Quantity represented
T1	No	No	Incident flux in initial reading
T2	Yes (before test)	No	Flux transmitted by the new material in a field of 24 degrees C
T3	Yes (after test)	No	Flux transmitted by the tested material in a field of 24 degrees C
T4	Yes (before test)	Yes	Flux diffused by the new material
T5	Yes (after test)	Yes	Flux diffused by the tested material

---

<sup>1/</sup> For L2 it is recommended to use a focal distance of about 80 mm.

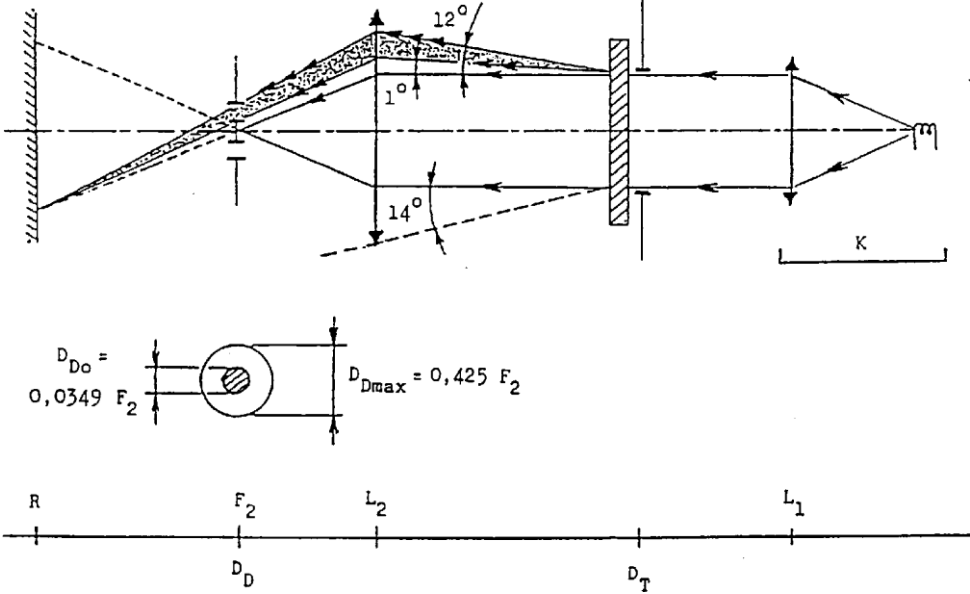

## **Annex 6 - Appendix 3**

### **SPRAY TESTING METHOD**

#### **1. Test equipment**

##### **1.1. Spray gun**

The spray gun used shall be equipped with a nozzle 1.3 mm in diameter allowing a liquid flow rate of 0.24 +/- 0.02 l/minute at an operating pressure of 6.0 bars - 0, + 0.5 bar. Under these operation conditions the fan pattern obtained shall be 170 mm +/- 50 mm in diameter on the surface exposed to deterioration, at a distance of 380 mm +/- 10 mm from the nozzle.

##### **1.2. Test mixture**

The test mixture shall be composed of:

Silica sand of hardness 7 on the Mohr scale, with a grain size between 0 and 0.2 mm and an almost normal distribution, with an angular factor of 1.8 to 2;

Water of hardness no exceeding 205 g/m<sup>3</sup> for a mixture comprising 25 g of sand per litre of water.

#### **2. Test**

The outer surface of the lamp lenses shall be subjected once or more than once to the action of the sand jet produced as described above. The jet shall be sprayed almost perpendicular to the surface to be tested.

The deterioration shall be checked by means of one or more samples of glass placed as a reference near the lenses to be tested. The mixture shall be sprayed until the variation in the diffusion of light on the sample or samples measured by the method described in appendix 2, is such that:

$$\Delta d = \frac{T5 - T4}{T_2} = 0.0250 \pm 0.0025$$

Several reference samples may be used to check that the whole surface to be tested has deteriorated homogeneously.

## **Annex 6 - Appendix 4**

### **ADHESIVE TAPE ADHERENCE TEST**

#### **1. PURPOSE**

This method allows to determine under standard conditions the linear force of adhesion of an adhesive tape to a glass plate.

#### **2. PRINCIPLE**

Measurement of the force necessary to unstick an adhesive tape from a glass plate at an angle of 90 degrees.

#### **3. SPECIFIED ATMOSPHERIC CONDITIONS**

The ambient conditions shall be at 23 degrees C +/- 5 degrees C and 65 +/- 15% relative humidity (RH).

#### **4. TEST PIECES**

Before the test, the sample roll of adhesive tape shall be conditioned for 24 hours in the specified atmosphere (see para. 3 above).

Five test pieces each 400 mm long shall be tested from each roll. These test pieces shall be taken from the roll after the first three turns were discarded.

#### **5. PROCEDURE**

The test shall be under the ambient conditions specified in paragraph 3.

Take the five test pieces while unrolling the tape radially at a speed of approximately 300 mm/s, then apply them within 15 seconds in the following manner:

Apply the tape to the glass plate progressively with a slight lengthwise rubbing movement of the finger, without excessive pressure, in such a manner as to leave no air bubble between the tape and the glass plate.

Leave the assembly in the specified atmospheric conditions for 10 minutes.

Unstick about 25 mm of the test piece from the plate in a plane perpendicular to the axis of the test piece.

Fix the plate and fold back the free end of the tape at 90 degrees. Apply force in such a manner that the separation line between the tape and the plate is perpendicular to this force and perpendicular to the plate.

Pull to unstick at a speed of 300 mm/s +/- 30 mm/s and record the force required.

#### **6. RESULTS**

The five values obtained shall be arranged in order and the median value taken as the result of the measurement. This value shall be expressed in Newtons per centimetre of width of the tape.

## Annex 7

### MINIMUM REQUIREMENTS FOR SAMPLING BY AN INSPECTOR

#### 1. GENERAL

1.1. The conformity requirements shall be considered satisfied from a mechanical and a geometric standpoint, in accordance with the requirements of this Regulation, if any, if the differences do not exceed inevitable manufacturing deviations.

1.2. With respect to photometric performance, the conformity of mass-produced headlamps shall not be contested if, when testing photometric performances of any headlamp chosen at random and equipped with a standard filament lamp;

1.2.1. no measured value deviates unfavourably by more than 20 % from the values prescribed in this Regulation.

For values B 50 L (or R) and Zone III the maximum deviation may be respectively:

B 50 L (or R): 0.2 lambdax equivalent 20 %

0.3 lambdax equivalent 30 %

Zone III: 0.3 lambdax equivalent 20 %

0.45 lambdax equivalent 30 %

1.2.2. or if

1.2.2.1. for the passing beam, the prescribed values in this Regulation are met at HV (with a tolerance of 0.2 lambda x) and related to that aiming at least one point of each area delimited on the measuring screen (at 25 m) by a circle 15 cm in radius around points B 50 L (or R) (with a tolerance of 0.1 lambda x), 75 R (or L), 50 V, 25 R, 25 L, and in the entire area of zone IV which is not more than 22.5 cm above line 25 R and 25 L;

1.2.2.2. and if, for the driving beam, HV being situated within the isolux 0.75 E<sub>max</sub>, a tolerance of +20 % for maximum values and -20 % for minimum values is observed for the photometric values at any measuring point specified in paragraph 6.3.2. of this Regulation. The reference mark is disregarded.

1.2.3. If the results of the tests described above do not meet the requirements, the alignment of the headlamp may be changed, provided that the axis of the beam is not displaced laterally by more than 1 degrees to the right or left.<sup>13/</sup>

1.2.4. If the results of the tests described above do not meet the requirements, tests on the headlamp shall be repeated using another standard filament lamp.

1.2.5. Headlamps with apparent defects are disregarded.

1.2.6. The reference mark is disregarded.

1.3. The chromaticity coordinates shall be complied with when the headlamp is equipped with a filament lamp set to Standard A colour temperature.

The photometric performance of a headlamp emitting selective yellow light when equipped with a colourless filament lamp shall be multiplied by 0.84.

<sup>13/</sup> See the corresponding footnote in the text of the Regulation.

## 2. FIRST SAMPLING

In the first sampling four headlamps are selected at random. The first sample of two is marked A, the second sample of two is marked B.

### 2.1. The conformity is not contested

2.1.1. Following the sampling procedure shown in Figure 1 of this Annex the conformity of mass-produced headlamps shall not be contested if the deviation of the measured values of the headlamps in the unfavourable directions are:

#### 2.1.1.1. sample A

A1:	one headlamp		0%
	one headlamp	not more than	20%
A2:	both headlamps	more than	0%
	but	not more than	20%

go to sample B

#### 2.1.1.2. sample B

B1:		both headlamps	0%
-----	--	----------------	----

2.1.2. or if the conditions of paragraph 1.2.2. for sample A are fulfilled.

### 2.2. The conformity is contested

2.2.1. Following the sampling procedure shown in Figure 1 of this Annex the conformity of mass-produced headlamps shall be contested and the manufacturer requested to make his production meet the requirements (alignment) if the deviations of the measured values of the headlamps are:

#### 2.2.1.1. sample A

A3:	one headlamp	not more than	20%
	one headlamp	more than	20%
	but	not more than	30%

#### 2.2.1.2. sample B

B2: in the case of A2

	one headlamp	more than	0%
	but	not more than	20%
	one headlamp	not more than	20%

B3: in the case of A2

	one headlamp		0%
	one headlamp	more than	20%
	but	not more than	30%

2.2.2. or if the conditions of paragraph 1.2.2. for sample A are not fulfilled.

2.3. Approval withdrawn

Conformity shall be contested and paragraph 13 applied if, following the sampling procedure in Figure 1 of this Annex, the deviations of the measured values of the headlamps are:

2.3.1. sample A

A4:	one headlamp	not more than	20%
	one headlamp	more than	30%
A5:	both headlamps	more than	20%

2.3.2. sample B

B4: in the case of A2

	one headlamp	more than	0%
	but	not more than	20%
	one headlamp	more than	20%

B5: in the case of A2

	both headlamps	more than	20%
--	----------------	-----------	-----

B6: in the case of A2

	one headlamp		0%
	one headlamp	more than	30%

2.3.3. or if the conditions of paragraph 1.2.2. for samples A and B are not fulfilled.

**3. REPEATED SAMPLING**

In the cases of A3, B2, B3 a repeated sampling, third sample C of two headlamps and fourth sample D of two headlamps, selected from stock manufactured after alignment, is necessary within two months time after the notification.

3.1. The conformity is not contested

3.1.1. Following the sampling procedure shown in Figure 1 of this Annex the conformity of mass-produced headlamps shall not be contested if the deviations of the measured values of the headlamps are:

3.1.1.1. sample C

C1:	one headlamp		0%
	one headlamp	not more than	20%
C2:	both headlamps	more than	0%
	but	not more than	20%

go to sample D

3.1.1.2. sample D

D1: in the case of C2

	both headlamps		0%
--	----------------	--	----

3.1.2. or if the conditions of paragraph 1.2.2. for sample C are fulfilled.

3.2. The conformity is contested

3.2.1. Following the sampling procedure shown in Figure 1 of this Annex the conformity of mass-produced headlamps shall be contested and the manufacturer requested to make his production meet the requirements (alignment) if the deviations of the measured values of the headlamps are:

3.2.1.1. sample D

D2: in the case of C2

one headlamp	more than	0%
but	not more than	20%
one headlamp	not more than	20%

3.2.1.2. or if the conditions of paragraph 1.2.2. for sample C are not fulfilled:

3.3. Approval withdrawn

Conformity shall be contested and paragraph 14 applied if, following the sampling procedure in Figure 1 of this Annex, the deviations of the measured values of the headlamps are:

3.3.1. sample C

C3: one headlamp	not more than	20%
one headlamp	more than	20%
C4: both headlamps	more than	20%

3.3.2. sample D

D3: in the case of C2

one headlamp	0 or more than	0%
one headlamp	more than	20%

3.3.3. or if the conditions of paragraph 1.2.2. for samples C and D are not fulfilled.

**4. CHANGE OF THE VERTICAL POSITION OF THE CUT-OFF LINE**

With respect to the verification of the change in vertical positions of the cut-off line under the influence of heat, the following procedure shall be applied:

One of the headlamps of sample A after sampling procedure in Figure 1 of this Annex shall be tested according to the procedure described in paragraph 2.1. of Annex 4 after being subjected three consecutive times to the cycle described in paragraph 2.2.2. of Annex 4.

The headlamp shall be considered as acceptable if  $D_r$  does not exceed 1.5 mrad.

If this value exceeds 1.5 mrad but is not more than 2.0 mrad, the second headlamp of sample A shall be subjected to the test after which the mean of the absolute values recorded in both samples shall not exceed 1.5 mrad.

However, if this value of 1.5 mrad on sample A is not complied with, the two headlamps of sample B shall be subjected to the same procedure and the value of  $D_r$  for each of them shall not exceed 1.5 mrad.

