



Heavy Vehicle National Law

South Australia Class 3 Heavy Vehicle 23m Truck and Dog Trailer Mass and Dimension Exemption Notice 2017 (No.1)

Statutory Instrument Series

Class 1/3 Heavy Vehicle Exemption Notice

1 Purpose

The purpose of this Notice is to exempt Class 3 heavy vehicle 23m long truck and dog trailer combinations from stated mass and dimension limits in Schedule 1 and 6 of the *Heavy Vehicle (Mass, Dimension and Loading) National Regulation (the Regulation)*.

Note- This Notice replaces Schedule 3 of the *South Australia Consolidated National Heavy Vehicle Mass and Dimension Notice 2014*. It includes new provisions for three axle truck and four axle dog trailer combinations that were not available in the original notice.

2 Authorising Provision

This Notice is made under section 117 of the Heavy Vehicle National Law (HVNL).

3 Title

This Notice may be cited as the South Australia Class 3 Heavy Vehicle 23m Truck and Dog Trailer Mass and Dimension Exemption Notice 2017.

4 Commencement

This Notice commences on the date of publication.

5 Expiry

This Notice expires five years after publication.

6 Definitions

In this Notice—

23m Truck and Dog Trailer means a combination consisting of a truck with 3 axles towing a dog trailer with 3, 4 or 5 axles.

7 Application

- (1) This Notice applies to 23m Truck and Dog Trailers operating in South Australia.
- (2) This Notice applies to a 23m Truck and Dog Trailer combination where:-
 - a) the truck has a single steer axle and a dual-drive tandem axle group; and,
 - b) the three axle dog trailer has a single axle at the front and a tandem axle group at the rear; and
 - c) the four axle dog has a tandem group at the front and a tandem group at the rear; and

- d) the five axle dog trailer has a tandem axle group at the front and a tri-axle group at the rear.

8 Exemption from prescribed mass and dimension requirements

(1) This Notice exempts 23m Truck and Dog Trailer combinations from the—

- a) dimension limit specified in Section 3(1)(a) of Schedule 6 of Regulation; and the
- b) mass limits specified in Section 2(1)(a)(iv) and 2(4) of Schedule 1 of the Regulation.

9 Conditions

(1) The mass of the 23m Truck and Dog Trailer operating under the general mass limits must not be more than—

- a) in the case of a combination consisting of a truck towing a 3 axle dog trailer – 48t;
- b) in the case of a combination consisting of a truck towing a 4 axle dog trailer- 55.5t;
- c) in the case of a combination consisting of a truck towing a 5 axle dog trailer– 59t.

(2) The mass of the 23m Truck and Dog Trailer operating under the general mass limits and with a complying steer axle must not be more than;

- a) In the case of a combination consisting of a truck towing a 3 axle dog trailer– 48.5t;
- b) In the case of a combination consisting of a truck towing a 4 axle dog trailer- 56t;
- c) In the case of a combination consisting of a truck towing a 5 axle dog trailer– 59.5t.

(3) The 23m Truck and Dog Trailer combination must not be longer than 23m.

- (4) The 23m Truck and Dog Trailer combination must comply with the minimum axle spacing requirements as per the configurations for each combination illustrated in the figures below:

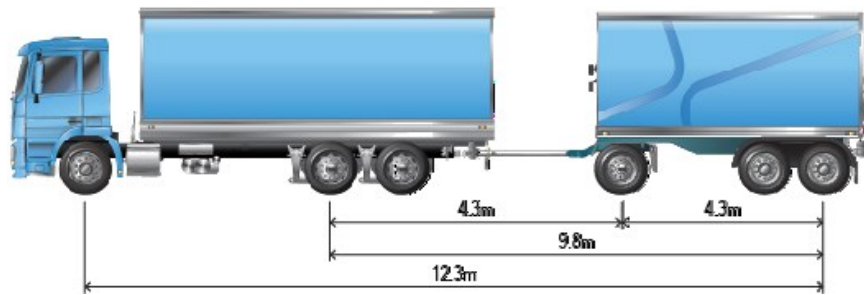

Figure 1 - Truck and three axle dog trailer minimum axle spacing

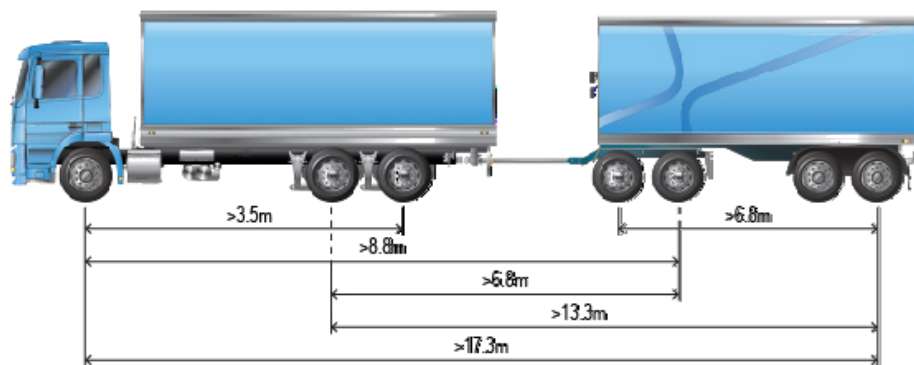

Figure 2 - Truck and four axle dog trailer minimum axle spacing

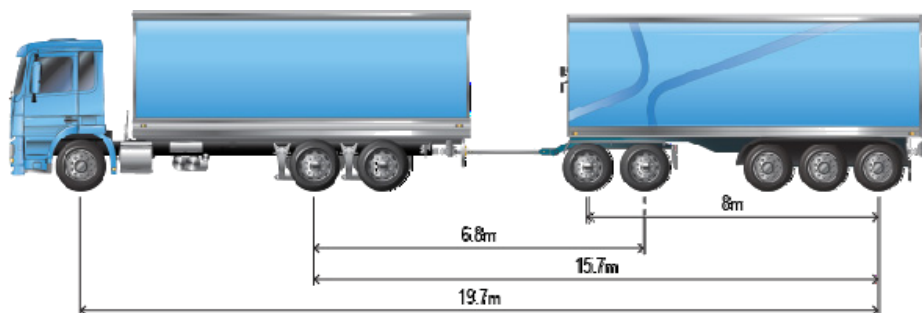

Figure 3 - Truck and five axle dog trailer minimum axle spacing

- (5) The 23m Truck and Dog Trailer combination must not exceed a speed of 80km/h or any posted speed limit whichever is the lesser.
- (6) A 23m Truck and Dog Trailer operating under this Notice is not permitted to operate under the Concessional Mass Limits or Higher Mass Limits.

- (7) 23m Truck and Dog trailer combinations operating under this notice must;
- a) Be inspected annually by a recognised road transport authority of their delegate,
or
 - b) Demonstrate compliance, with a recognised NHVAS or WAHVA maintenance accreditation.
- (8) If the 23m Truck and Dog trailer combination exceeds a length of 22m, a Long Vehicle sign must be displayed at the rear of the vehicle in accordance with clauses 5(3) and 6 of the *Heavy Vehicle (Vehicle Standards) National Regulation*.

10 Condition - Stated Areas and Routes

All 23m Truck and Dog Trailer combinations operating under this notice must only use '23m Truck and Dog Network' published by the South Australia Department of Planning Transport and Infrastructure (DIPTI).

Note:- network maps are available at the DIPTI website

DATED: 28 August 2017

Peter Caprioli
Executive Director Access
National Heavy Vehicle Regulator